

- **Controlled Baseline**
 - One Assembly/Test Site, One Fabrication Site
- **Extended Temperature Performance of –55°C to 125°C**
- **Enhanced Diminishing Manufacturing Sources (DMS) Support**
- **Enhanced Product Change Notification**
- **Qualification Pedigree†**
- **High-Performance Floating-Point Digital Signal Processor (DSP)**
 - SM320C32-50EP (5 V)**
 - 40-ns Instruction Cycle Time
 - 275 MOPS
 - 50 MFLOPS
 - 25 MIPS
 - SM320C32-60EP (5 V)**
 - 33-ns Instruction Cycle Time
 - 330 MOPS
 - 60 MFLOPS
 - 30 MIPS
- **32-Bit High-Performance CPU**
- **16-/32-Bit Integer and 32-/40-Bit Floating-Point Operations**
- **32-Bit Instruction Word, 24-Bit Addresses**
- **Two 256 × 32-Bit Single-Cycle, Dual-Access On-Chip RAM Blocks**
- **Flexible Boot-Program Loader**
- **On-Chip Memory-Mapped Peripherals:**
 - One Serial Port
 - Two 32-Bit Timers
 - Two-Channel Direct Memory Access (DMA) Coprocessor With Configurable Priorities
- **Enhanced External Memory Interface That Supports 8-/16-/32-Bit-Wide External RAM for Data Access and Program Execution From 16-/32-Bit-Wide External RAM**
- **SMJ320C30 and SMJ320C31 Object Code Compatible**
- **Fabricated Using Enhanced Performance Implanted CMOS (EPIC™) Technology by Texas Instruments**
- **144-Pin Plastic Quad Flatpack (PCM Suffix) 5 V**
- **Eight Extended-Precision Registers**
- **Two Address Generators With Eight Auxiliary Registers and Two Auxiliary Register Arithmetic Units (ARAUs)**
- **Two Low-Power Modes**
- **Two- and Three-Operand Instructions**
- **Parallel Arithmetic Logic Unit (ALU) and Multiplier Execution in a Single Cycle**
- **Block-Repeat Capability**
- **Zero-Overhead Loops With Single-Cycle Branches**
- **Conditional Calls and Returns**
- **Interlocked Instructions for Multiprocessing Support**
- **One External Pin, PRGW, That Configures the External-Program-Memory Width to 16 or 32 Bits**
- **Two Sets of Memory Strobes ($\overline{\text{STRB0}}$ and $\overline{\text{STRB1}}$) and One I/O Strobe ($\overline{\text{IOSTRB}}$) Allow Zero-Glue Logic Interface to Two Banks of Memory and One Bank of External Peripherals**
- **Separate Bus-Control Registers for Each Strobe-Control Wait-State Generation, External Memory Width, and Data Type Size**
- **$\overline{\text{STRB0}}$ and $\overline{\text{STRB1}}$ Memory Strobes Handle 8-, 16-, or 32-Bit External Data Accesses (Reads and Writes)**
- **Multiprocessor Support Through the $\overline{\text{HOLD}}$ and $\overline{\text{HOLDA}}$ Signals Is Valid for All Strobes**



Please be aware that an important notice concerning availability, standard warranty, and use in critical applications of Texas Instruments semiconductor products and disclaimers thereto appears at the end of this data sheet.

† Component qualification in accordance with JEDEC and industry standards to ensure reliable operation over an extended temperature range. This includes, but is not limited to, Highly Accelerated Stress Test (HAST) or biased 85/85, temperature cycle, autoclave or unbiased HAST, electromigration, bond intermetallic life, and mold compound life. Such qualification testing should not be viewed as justifying use of this component beyond specified performance and environmental limits.

EPIC is a trademark of Texas Instruments Incorporated.
All trademarks are the property of their respective owners.

PRODUCTION DATA information is current as of publication date. Products conform to specifications per the terms of Texas Instruments standard warranty. Production processing does not necessarily include testing of all parameters.



Copyright © 2002, Texas Instruments Incorporated

SM320C32-EP

DIGITAL SIGNAL PROCESSOR

SGUS038 – AUGUST 2002

description

The SM320C32-EP is a member of the 320C3x generation of digital signal processors from Texas Instruments. The SM320C32-EP is an enhanced 32-bit floating-point processor manufactured in 0.7- μm triple-level-metal CMOS technology. The enhancements to the 320C3x architecture include a variable-width external-memory interface, faster instruction cycle time, power-down modes, two-channel DMA coprocessor with configurable priorities, flexible bootloader, relocatable interrupt-vector table, and edge- or level-triggered interrupts.

The internal busing and special digital signal processing instruction set of the SM320C32-EP have the speed and flexibility to execute up to 50 million floating-point operations per second (MFLOPS). The SM320C32-EP optimizes speed by implementing functions in hardware that other processors implement through software or microcode. This hardware-intensive approach provides performance previously unavailable on a single chip.

For additional information when designing for cold temperature operation, please see Texas Instruments application report *320C3x, 320C4x and 320MCM42x Power-up Sensitivity at Cold Temperature*, literature number SGUA001.

part order information

DEVICE	TECHNOLOGY	POWER SUPPLY	OPERATING FREQUENCY	PACKAGE TYPE	PROCESSING LEVEL
SM320C32PCMM50EP	0.65- μm CMOS	5 V \pm 5%	50 MHz	Plastic 144-lead quad flatpack	EP
SM320C32PCMM60EP	0.65- μm CMOS	5 V \pm 5%	60 MHz	Plastic 144-lead quad flatpack	EP



PCM PACKAGE†
(TOP VIEW)

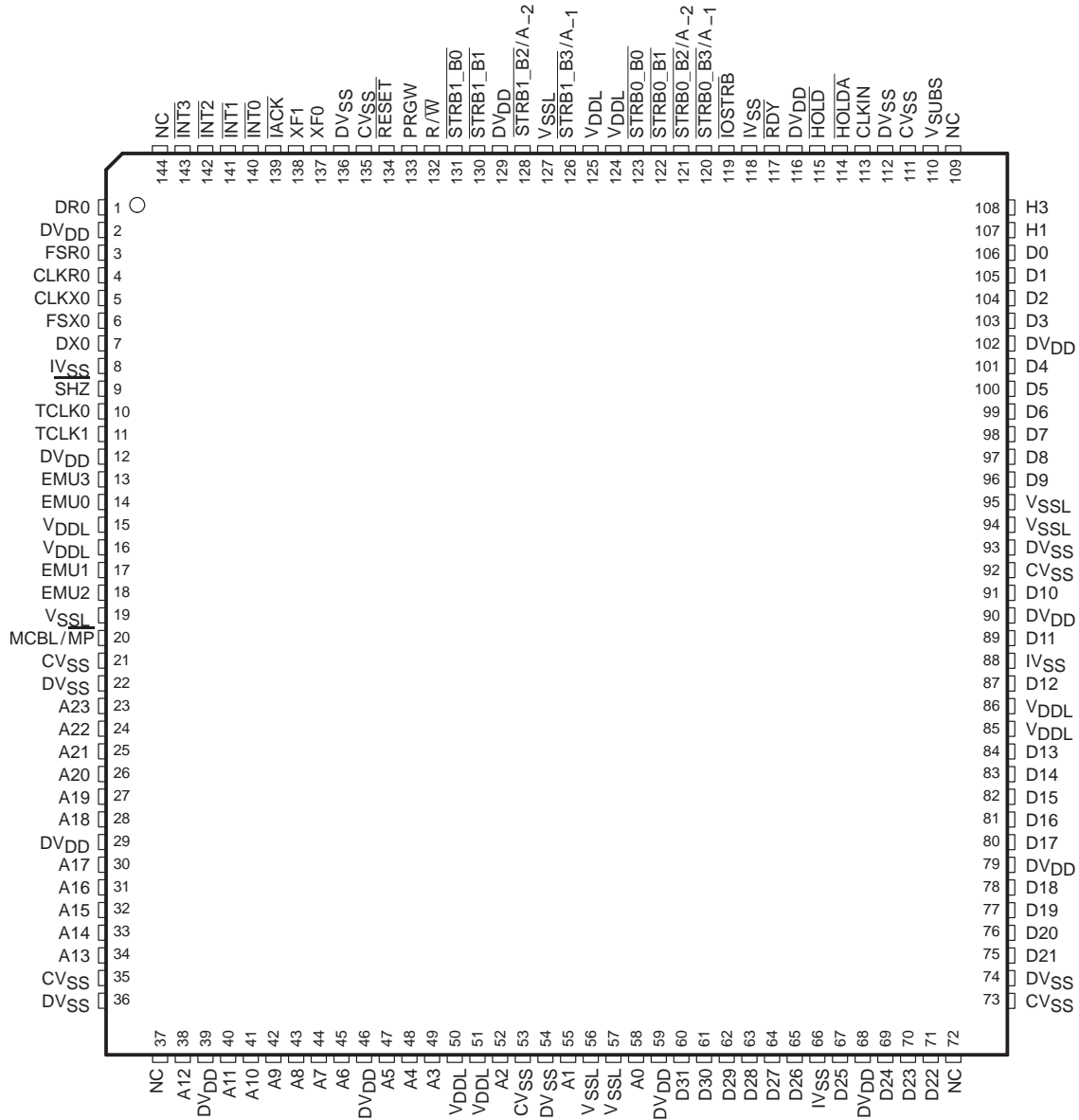

† NC=No internal connection

SM320C32-EP DIGITAL SIGNAL PROCESSOR

SGUS038 – AUGUST 2002

Pin Assignments

NO.	PIN NAME	NO.	PIN NAME	NO.	PIN NAME	NO.	PIN NAME	NO.	PIN NAME
1	DR0	30	A17	59	DV _{DD}	88	IV _{SS}	117	$\overline{\text{RDY}}$
2	DV _{DD}	31	A16	60	D31	89	D11	118	IV _{SS}
3	FSR0	32	A15	61	D30	90	DV _{DD}	119	$\overline{\text{IOSTRB}}$
4	CLKR0	33	A14	62	D29	91	D10	120	$\overline{\text{STRB0_B3/A_1}}$
5	CLKX0	34	A13	63	D28	92	CV _{SS}	121	$\overline{\text{STRB0_B2/A_2}}$
6	FSX0	35	CV _{SS}	64	D27	93	DV _{SS}	122	$\overline{\text{STRB0_B1}}$
7	DX0	36	DV _{SS}	65	D26	94	V _{SSL}	123	$\overline{\text{STRB0_B0}}$
8	IV _{SS}	37	NC	66	IV _{SS}	95	V _{SSL}	124	V _{DDL}
9	$\overline{\text{SHZ}}$	38	A12	67	D25	96	D9	125	V _{DDL}
10	TCLK0	39	DV _{DD}	68	DV _{DD}	97	D8	126	$\overline{\text{STRB1_B3/A_1}}$
11	TCLK1	40	A11	69	D24	98	D7	127	V _{SSL}
12	DV _{DD}	41	A10	70	D23	99	D6	128	$\overline{\text{STRB1_B2/A_2}}$
13	EMU3	42	A9	71	D22	100	D5	129	DV _{DD}
14	EMU0	43	A8	72	NC	101	D4	130	$\overline{\text{STRB1_B1}}$
15	V _{DDL}	44	A7	73	CV _{SS}	102	DV _{DD}	131	$\overline{\text{STRB1_B0}}$
16	V _{DDL}	45	A6	74	DV _{SS}	103	D3	132	R/ $\overline{\text{W}}$
17	EMU1	46	DV _{DD}	75	D21	104	D2	133	PRGW
18	EMU2	47	A5	76	D20	105	D1	134	$\overline{\text{RESET}}$
19	V _{SSL}	48	A4	77	D19	106	D0	135	CV _{SS}
20	MCBL/ $\overline{\text{MP}}$	49	A3	78	D18	107	H1	136	DV _{SS}
21	CV _{SS}	50	V _{DDL}	79	DV _{DD}	108	H3	137	XF0
22	DV _{SS}	51	V _{DDL}	80	D17	109	NC	138	XF1
23	A23	52	A2	81	D16	110	V _{SUBS}	139	$\overline{\text{IACK}}$
24	A22	53	CV _{SS}	82	D15	111	CV _{SS}	140	$\overline{\text{INT0}}$
25	A21	54	DV _{SS}	83	D14	112	DV _{SS}	141	$\overline{\text{INT1}}$
26	A20	55	A1	84	D13	113	CLKIN	142	$\overline{\text{INT2}}$
27	A19	56	V _{SSL}	85	V _{DDL}	114	$\overline{\text{HOLDA}}$	143	$\overline{\text{INT3}}$
28	A18	57	V _{SSL}	86	V _{DDL}	115	$\overline{\text{HOLD}}$	144	NC
29	DV _{DD}	58	A0	87	D12	116	DV _{DD}		



pin functions

This section provides signal descriptions for the SM320C32-EP device. The following table lists each signal (grouped by function), the number of pins, operating modes, and a brief signal description.

Pin Functions

PIN NAME	NO.	TYPE†	DESCRIPTION	CONDITIONS WHEN SIGNAL IS IN HIGH Z‡
EXTERNAL BUS INTERFACE (70 PINS)				
D31–D0	32	I/O/Z	32-bit data port of the external bus interface	S H R
A23–A0	24	O/Z	24-bit address port of the external bus interface	S H R
R/ \overline{W}	1	O/Z	Read/write for external memory interface. R/ \overline{W} is high when a read is performed and low when a write is performed over the parallel interface.	S H R
\overline{IOSTRB}	1	O/Z	External peripheral I/O strobe for the external memory interface	S H
$\overline{STRB0_B3/A_1}$	1	O/Z	External memory-access strobe 0, byte enable 3 for 32-bit external memory interface and address pin for 8-bit and 16-bit external memory interface	S H
$\overline{STRB0_B2/A_2}$	1	O/Z	External memory-access strobe 0, byte enable 2 for 32-bit external memory interface and address pin for 8-bit external memory interface	S H
$\overline{STRB0_B1}$	1	O/Z	External memory-access strobe 0, byte enable 1 for the external memory interface	S H
$\overline{STRB0_B0}$	1	O/Z	External memory-access strobe 0, byte enable 0 for the external memory interface	S H
$\overline{STRB1_B3/A_1}$	1	O/Z	External memory-access strobe 1, byte enable 3 for 32-bit external memory interface and address pin for 8-bit and 16-bit external memory interface	S H
$\overline{STRB1_B2/A_2}$	1	O/Z	External memory-access strobe 1, byte enable 2 for 32-bit external memory interface and address pin for 8-bit external memory interface	S H
$\overline{STRB1_B1}$	1	O/Z	External memory-access strobe 1, byte enable 1 for the external memory interface	S H
$\overline{STRB1_B0}$	1	O/Z	External memory-access strobe 1, byte enable 0 for the external memory interface	S H
\overline{RDY}	1	I	Ready. \overline{RDY} indicates that the external device is prepared for an external memory interface transaction to complete.	
\overline{HOLD}	1	I	Hold signal for external memory interface. When \overline{HOLD} is a logic low, any ongoing transaction is completed. A23–A0, D31–D0, \overline{IOSTRB} , $\overline{STRB0_Bx}$, $\overline{STRB1_Bx}$, and R/ \overline{W} are placed in the high-impedance state, and all transactions over the external memory interface are held until \overline{HOLD} becomes a logic high or the NOHOLD bit of the STRB0 bus-control register is set.	
\overline{HOLDA}	1	O/Z	Hold acknowledge for external memory interface. \overline{HOLDA} is generated in response to a logic low on \overline{HOLD} . \overline{HOLDA} indicates that A23–A0, D31–D0, \overline{IOSTRB} , $\overline{STRB0_Bx}$, $\overline{STRB1_Bx}$, and R/ \overline{W} are in the high-impedance state and that all transactions over the memory are held. \overline{HOLDA} is high in response to a logic high of \overline{HOLD} or when the NOHOLD bit of the external bus-control register is set.	S
PRGW	1	I	Program memory width select. When PRGW is a logic low, program is fetched as a single 32-bit word. When PRGW is a logic high, two 16-bit program fetches are performed to fetch a single 32-bit instruction word. The status of PRGW at device reset affects the reset value of the STRB0 and STRB1 bus-control register.	

† I = input, O = output, Z = high-impedance state

‡ S = SHZ active, H = HOLD active, R = RESET active

§ Recommended decoupling capacitor is 0.1 μ F.

SM320C32-EP DIGITAL SIGNAL PROCESSOR

SGUS038 – AUGUST 2002

Pin Functions (Continued)

PIN NAME	NO.	TYPE†	DESCRIPTION	CONDITIONS WHEN SIGNAL IS IN HIGH ‡	
CONTROL SIGNALS (9 PINS)					
$\overline{\text{RESET}}$	1	I	Reset. When $\overline{\text{RESET}}$ is a logic low, the device is in the reset condition. When $\overline{\text{RESET}}$ becomes a logic high, execution begins from the location specified by the reset vector.		
$\overline{\text{INT3}} - \overline{\text{INT0}}$	4	I	External interrupts		
CONTROL SIGNALS (9 PINS) (CONTINUED)					
$\overline{\text{IACK}}$	1	O/Z	Interrupt acknowledge. $\overline{\text{IACK}}$ is set to a logic high by the IACK instruction. This signal can be used to indicate the beginning or end of an interrupt-service routine.	S	
$\overline{\text{MCBL}} / \overline{\text{MP}}$	1	I	Microcomputer bootloader/microprocessor mode		
$\text{XF1} - \text{XF0}$	2	I/O/Z	External flags. XF1 and XF0 are used as general-purpose I/Os or used to support interlocked-processor instructions.	S	R
SERIAL PORT SIGNALS (6 PINS)					
CLKX0	1	I/O/Z	Serial port 0 transmit clock. CLKX0 is the serial shift clock for the serial port 0 transmitter.	S	R
DX0	1	I/O/Z	Data transmit output. Serial port 0 transmits serial data on DX0.	S	R
FSX0	1	I/O/Z	Frame-synchronization pulse for transmit. The FSX0 pulse initiates the transmit-data process over DX0.	S	R
CLKR0	1	I/O/Z	Serial port 0 receive clock. CLKR0 is the serial shift clock for the serial port 0 receiver.	S	R
DR0	1	I/O/Z	Data receive. Serial port 0 receives serial data on DR0.	S	R
FSR0	1	I/O/Z	Frame-synchronization pulse for receive. The FSR0 pulse initiates the receive-data process over DR0.	S	R
TIMER SIGNALS (2 PINS)					
TCLK0	1	I/O/Z	Timer clock 0. As an input, TCLK0 is used by timer 0 to count external pulses. As an output, TCLK0 outputs pulses generated by timer 0.	S	R
TCLK1	1	I/O/Z	Timer clock 1. As an input, TCLK1 is used by timer 1 to count external pulses. As an output, TCLK1 outputs pulses generated by timer 1.	S	R
CLOCK SIGNALS (3 PINS)					
CLKIN	1	I	Input to the internal oscillator from an external clock source		
H1	1	O/Z	External H1 clock. H1 has a period equal to twice CLKIN.	S	
H3	1	O/Z	External H3 clock. H3 has a period equal to twice CLKIN.	S	
RESERVED (5 PINS)					
$\text{EMU0} - \text{EMU2}$	3	I	Reserved for emulation. Use 18 k Ω – 22 k Ω pullup resistors to 5 V.		
EMU3	1	O/Z	Reserved for emulation	S	
$\overline{\text{SHZ}}$	1	I	Shutdown high impedance. When active, $\overline{\text{SHZ}}$ shuts down the C32 and places all 3-state I/O pins in the high-impedance state. $\overline{\text{SHZ}}$ is used for board-level testing to ensure that no dual drive conditions occur. CAUTION: A low on $\overline{\text{SHZ}}$ corrupts C32 memory and register contents. Reset the device with $\overline{\text{SHZ}}$ high to restore it to a known operating condition.		

† I = input, O = output, Z = high-impedance state

‡ S = $\overline{\text{SHZ}}$ active, H = HOLD active, R = RESET active

§ Recommended decoupling capacitor is 0.1 μF .



Pin Functions (Continued)

PIN NAME	NO.	TYPE†	DESCRIPTION	CONDITIONS WHEN SIGNAL IS IN HIGH Z‡
POWER/GROUND				
CVSS	7	I	Ground	
DVSS	7	I	Ground	
IVSS	4	I	Ground	
DVDD	12	I	5 V _{dc} supply§	
VDDL	8	I	5 V _{dc} supply§	
VSSL	6	I	Ground	
VSUBS	1	I	Substrate, tie to ground	

† I = input, O = output, Z = high-impedance state

‡ S = SHZ active, H = HOLD active, R = RESET active

§ Recommended decoupling capacitor is 0.1 μF.

SM320C32-EP DIGITAL SIGNAL PROCESSOR

SGUS038 – AUGUST 2002

functional block diagram

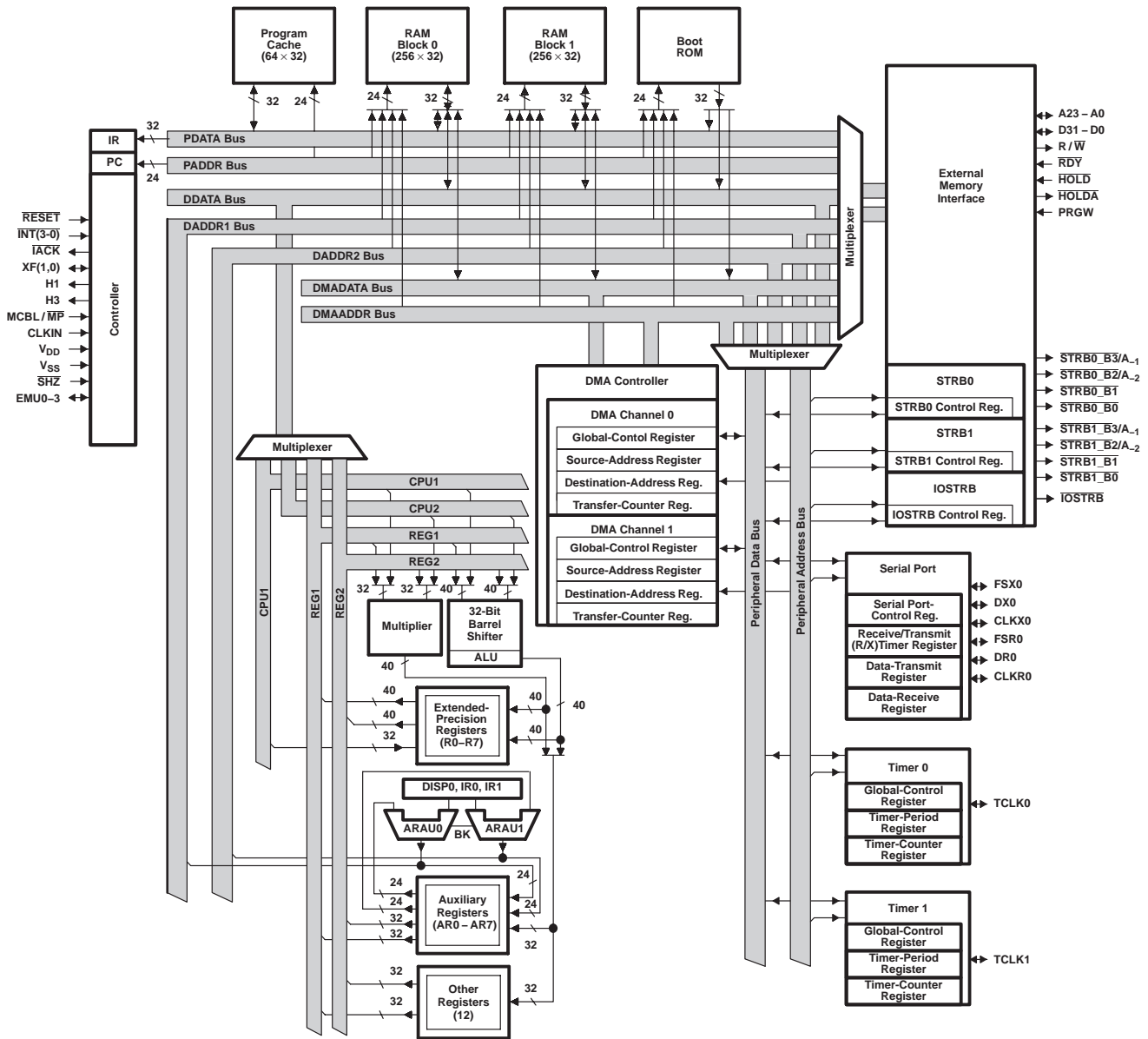

operation

Operation of the SM320C32-EP is identical to the 320C30 and 320C31 digital signal processors, with the exception of an enhanced external memory interface and the addition of two CPU power-management modes.

external memory interface

The SM320C32-EP has a configurable external memory interface with a 24-bit address bus, a 32-bit data bus, and three independent multi-function strobes. The flexibility of this unique interface enables product designers to minimize external memory-chip count.



external memory interface (continued)

Up to three mutually exclusive memory areas—one program area and two data areas—can be implemented. Each memory area configuration is independent of the physical memory width and independent of the other memory areas configurations. See Figure 1.

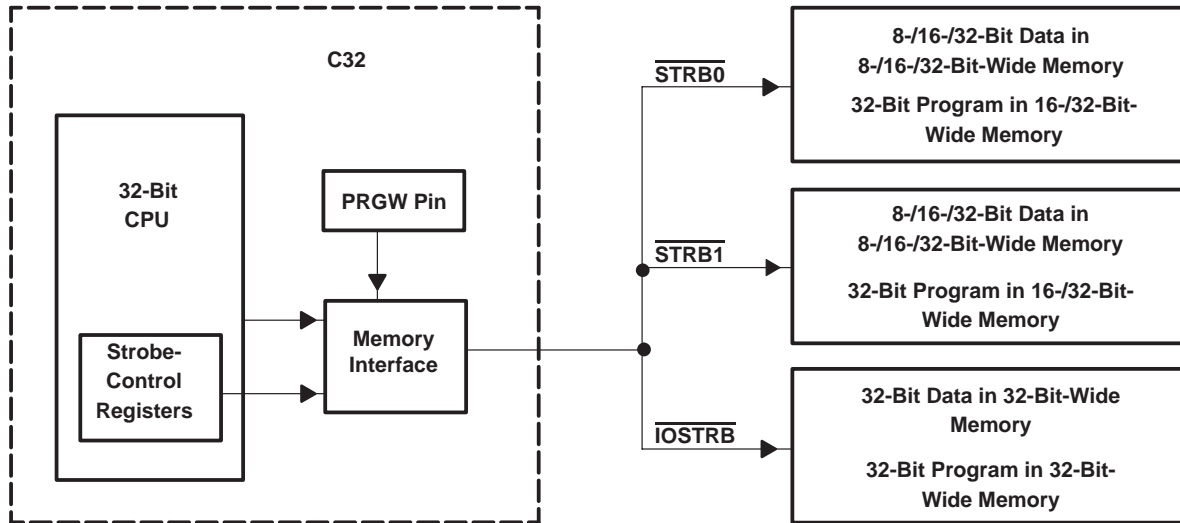

Figure 1. C32 External Memory Interface

The SM320C32-EP external memory configuration is controlled by a combination of hardware configuration and memory-mapped control registers and can be reconfigured dynamically. The signals that control external memory configuration are the PRGW, $\overline{\text{STRB0}}$, $\overline{\text{STRB1}}$, and $\overline{\text{IOSTRB}}$. The signals work as follows:

- The SM320C32-EP is a 32-bit microprocessor, that is, the CPU operates on 32-bit program words. The external memory interface provides the capability of fetching instructions as either 32-bit words or two 16-bit half words from consecutive addresses. Program memory width is 16 bits if the PRGW signal is high, 32 bits if the PRGW signal is low.
- $\overline{\text{STRB0}}$ and $\overline{\text{STRB1}}$ are sets of control signals, four signals each, that are mapped to specific ranges of external memory addresses. When an address within one of these ranges is accessed by a read or write instruction (CPU or DMA), the corresponding set of control signals is activated. Figure 8 illustrates the SM320C32-EP memory map, showing the address ranges for which the strobe signals become active.

The behavior of the $\overline{\text{STRB0}}$ and $\overline{\text{STRB1}}$ control signals is determined by the contents of the $\overline{\text{STRB0}}$ and $\overline{\text{STRB1}}$ control registers.

The $\overline{\text{STRB0}}$ and $\overline{\text{STRB1}}$ control registers each have a field that specifies the physical memory width (8, 16, or 32 bits) of the external memory address ranges they control. Another field specifies the data width (8, 16, or 32 bits) of the data contained in those addresses. The values in these fields are not required to match. For example, a 32-bit-wide physical memory space can be configured to segment each 32-bit word into four consecutive 8-bit locations, each having its own address.

Each control signal set has two pins ($\overline{\text{STRBx_B2/A_2}}$ and $\overline{\text{STRBx_B3/A_1}}$) that can act as either byte-enable (chip-select) pins or address pins, and two dedicated byte-enable (chip-select) pins ($\overline{\text{STRBx_B0}}$ and $\overline{\text{STRBx_B1}}$). The pin functions are determined by the physical memory width specified in the corresponding control register:

SM320C32-EP DIGITAL SIGNAL PROCESSOR

SGUS038 – AUGUST 2002

external memory interface (continued)

- For 8-bit-wide physical memory, the $\overline{\text{STRBx_B2/A_2}}$ and $\overline{\text{STRBx_B3/A_1}}$ pins function as address pins (least significant address bits) and the $\overline{\text{STRBx_B0}}$ pin functions as a byte-enable (chip-select) pin. $\overline{\text{STRBx_B1}}$ is unused. See Figure 2.

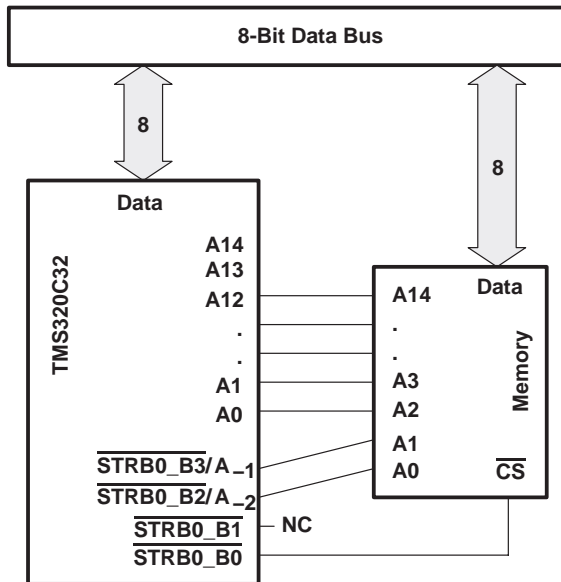

Figure 2. C32 With 8-Bit-Wide External Memory

- For 16-bit-wide physical memory, the $\overline{\text{STRBx_B3/A_1}}$ pin functions as an address pin (least significant address bits). The $\overline{\text{STRBx_B0}}$ and $\overline{\text{STRBx_B1}}$ pins function as byte-enable (chip-select) pins. $\overline{\text{STRBx_B2/A_2}}$ is unused. See Figure 3.

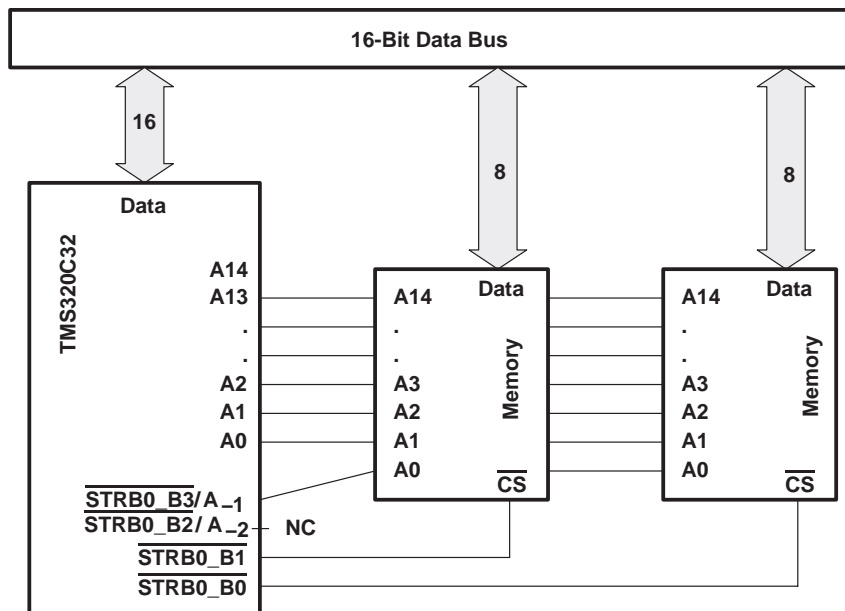

Figure 3. C32 With 16-Bit-Wide External Memory

external memory interface (continued)

- For 32-bit-wide physical memory, all $\overline{\text{STRB0}}$ and $\overline{\text{STRB1}}$ pins function as byte-enable (chip-select) pins. See Figure 4.

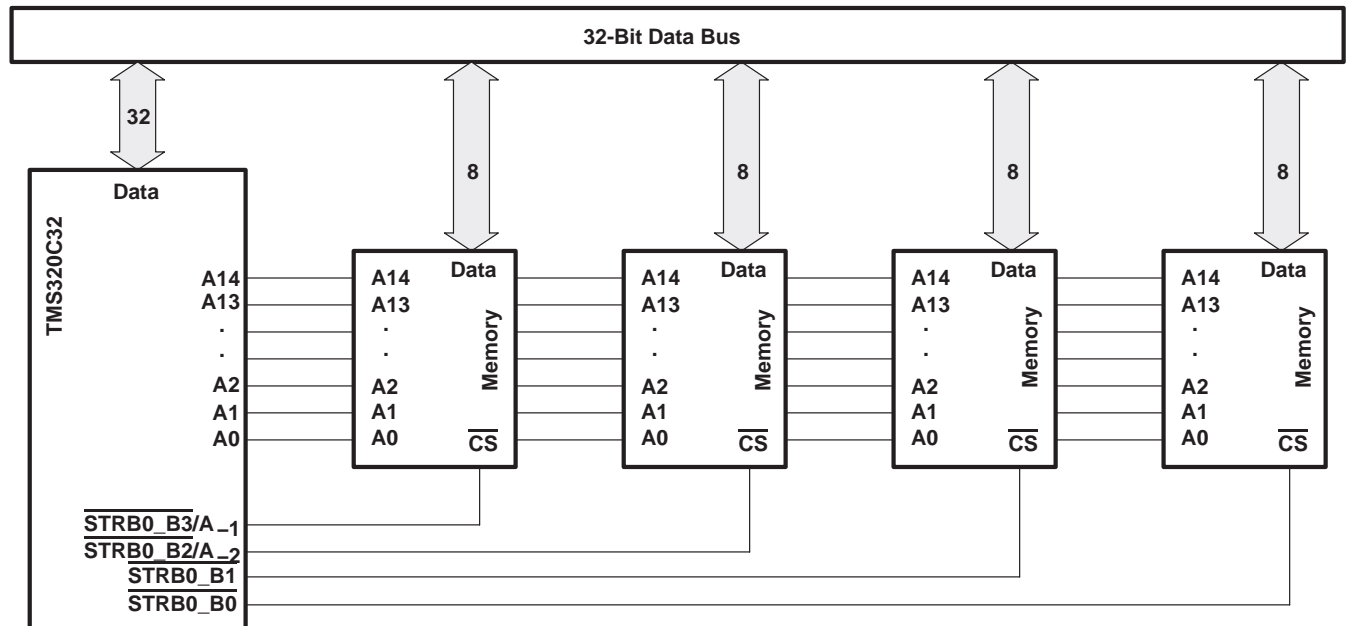

Figure 4. C32 With 32-Bit-Wide External Memory

For more detailed information and examples, see *TMS320C32 Addendum to the TMS320C3x User's Guide* (literature number SPRU132B) and *Interfacing Memory to the SMQ320C32 DSP Application Report* (literature number SPRA040).

- The $\overline{\text{IOSTRB}}$ control signal, like $\overline{\text{STRB0}}$ and $\overline{\text{STRB1}}$, is also mapped to a specific range of addresses but it is a single signal that can access only 32-bit data from 32-bit-wide memory. Its range of addresses appears in Figure 8, the SM320C32-EP memory map. The $\overline{\text{IOSTRB}}$ bus timing is different from the $\overline{\text{STRB0}}$ and $\overline{\text{STRB1}}$ bus timings to accommodate slower I/O peripherals.

examples

Figure 5 and Figure 6 show examples of external memory configurations that can be implemented using the SM320C32-EP external memory interface. The first example has a 32-bit-wide external memory with 8- and 16-bit data areas and a 32-bit program area.

SM320C32-EP DIGITAL SIGNAL PROCESSOR

SGUS038 – AUGUST 2002

examples (continued)

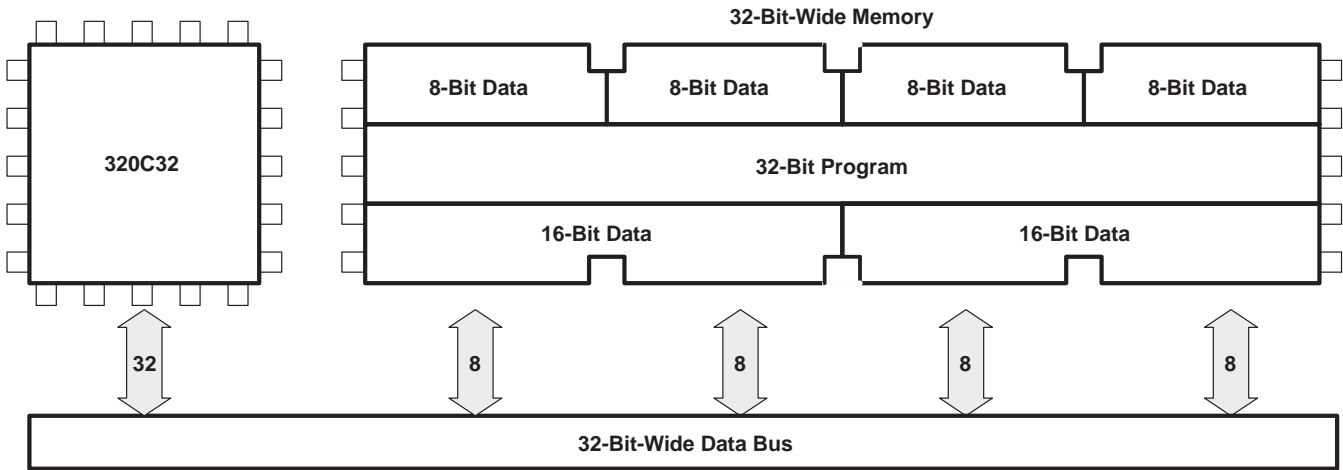

Figure 5. C32 With 32-Bit-Wide External Memory Configured With 8- and 16-Bit Data Areas and 32-Bit Program Memory

Figure 6 shows a configuration that can be implemented with a 16-bit external memory. Note that 32-bit data and program words can be stored and retrieved as half words.

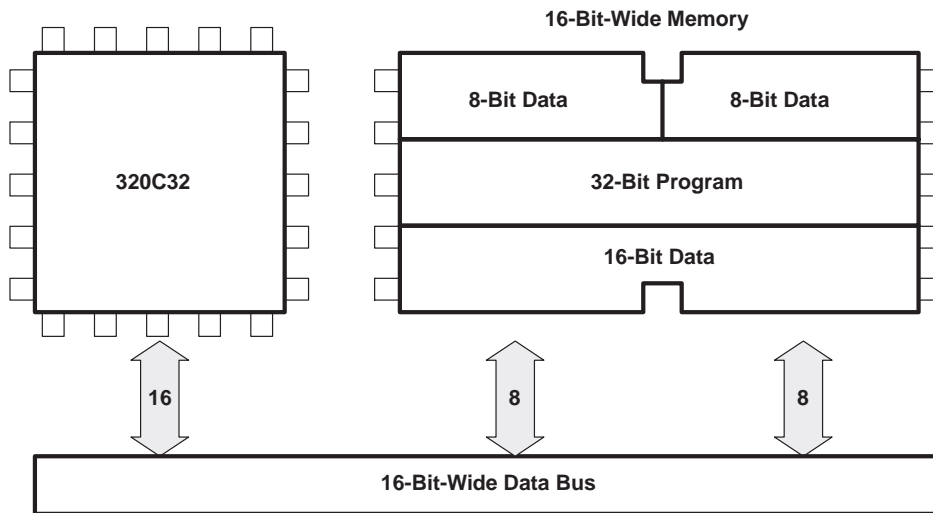

Figure 6. C32 With 16-Bit-Wide External Memory Configured With 8- and 16-Bit Data Areas and a 32-Bit Program Area

examples (continued)

Figure 7 shows one possible configuration that can be implemented with 8-bit external memory. Program words, which are 32-bit, cannot be executed from 8-bit-wide memory.

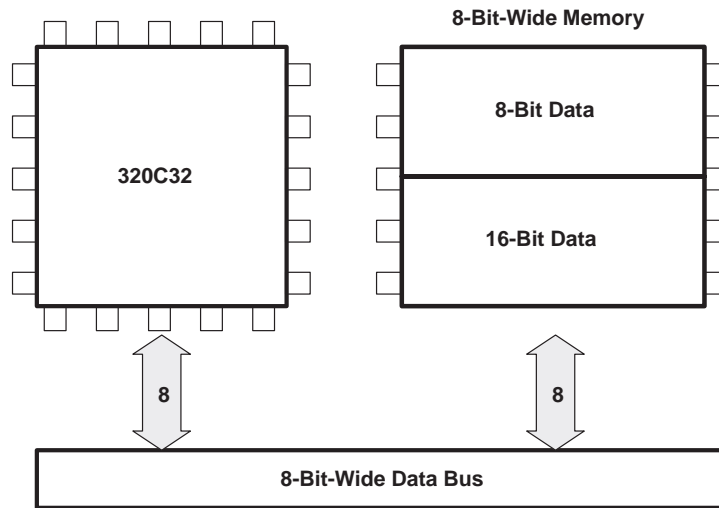

Figure 7. C32 With 8-Bit-Wide External Memory Configured With 8- and 16-Bit Data Areas

SM320C32-EP DIGITAL SIGNAL PROCESSOR

SGUS038 – AUGUST 2002

memory map

Figure 8 depicts the memory map for the SM320C32-EP. See the *TMS320C32 Addendum to the TMS320C3x User's Guide* (literature number SPRU132B) for a detailed description of this memory mapping.

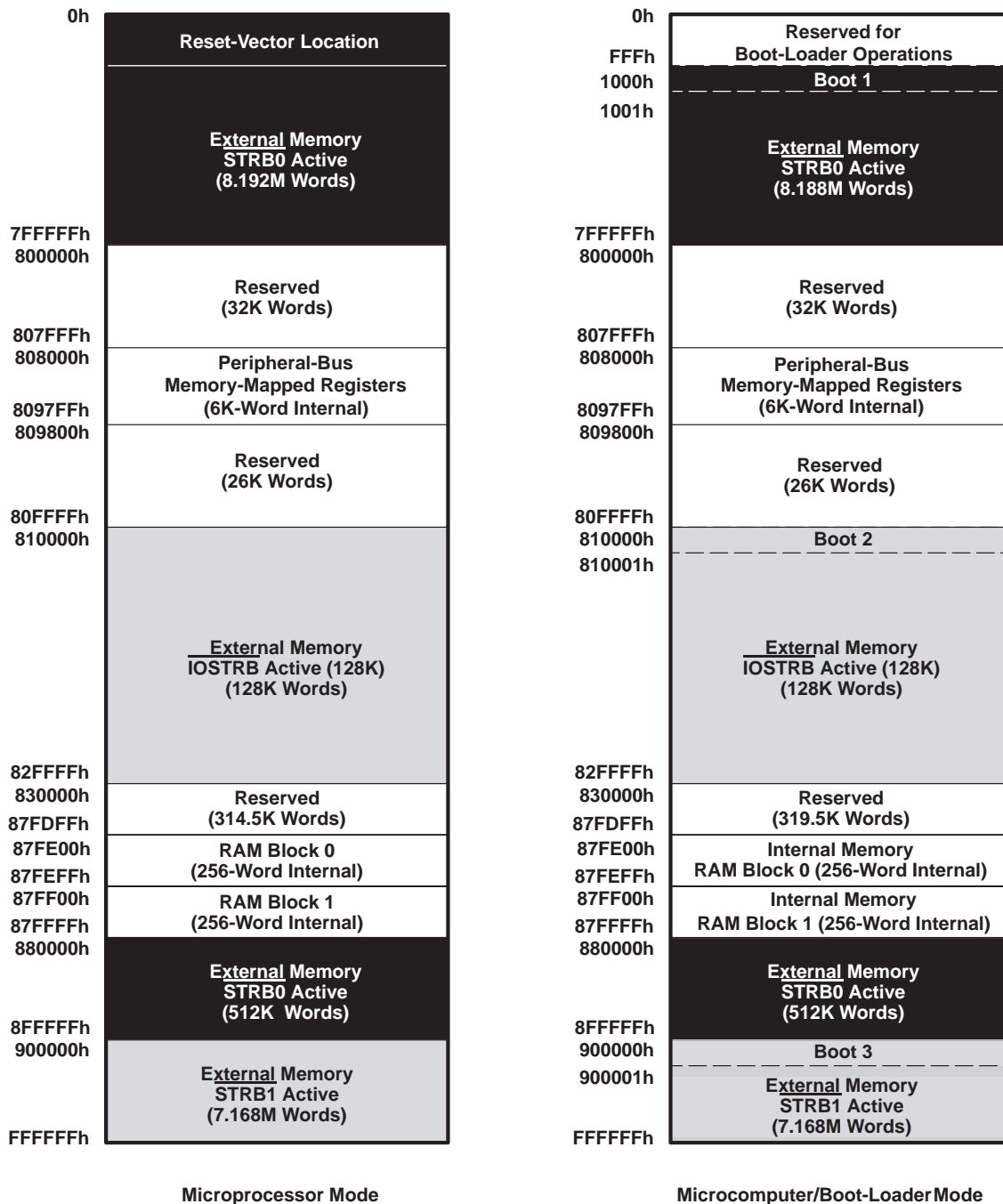

Figure 8. SM320C32-EP Memory Map

power management

The SM320C32-EP CPU has two power-management modes, IDLE2 and LOPOWER (low power). In IDLE2 mode, no instructions are executed and the CPU, peripherals, and memory retain their previous state while the external bus output pins are idle. During IDLE2 mode, the H1 clock signal is held high while the H3 clock signal is held low until one of the four external interrupts is asserted. In the LOPOWER mode, the CPU continues to execute instructions and the DMA continues to perform transfers, but at a reduced clock rate of the CLKIN frequency divided by 16 (that is, SM320C32-EP with a 32-MHz CLKIN frequency performs the same as a 2-MHz SM320C32-EP with an instruction cycle time of 1000 ns or 1 MHz).

bootloader

The SM320C32-EP flexible bootloader loads programs from the serial port, EPROM, or other standard non-volatile memory device. The boot-loader functionality of the SM320C32-EP is equivalent to that of the 320C31, and has added modes to handle the data-type sizes and memory widths supported by the external memory interface. The memory-bootload supports data transfers with and without handshaking. The handshake mode allows synchronous transfer of programs by using two pins as data-acknowledge and data-ready signals.

peripherals

The SM320C32-EP peripherals are comprised of one serial port, two timers, and two DMA channels. The serial port and timers are functionally identical to those in the 320C31 peripherals. The SM320C32-EP two-channel DMA coprocessor has user-configurable priorities: CPU, DMA, or rotating between CPU and DMA.

SM320C32-EP DIGITAL SIGNAL PROCESSOR

SGUS038 – AUGUST 2002

peripherals (continued)

Figure 9 shows the SM320C32-EP peripheral-bus control-register mapping.

808000h	DMA 0 Global Control
808004h	DMA 0 Source Address
808006h	DMA 0 Destination Address
808008h	DMA 0 Transfer Counter
808009h	
808010h	DMA 1 Global Control
808014h	DMA 1 Source Address
808016h	DMA 1 Destination Address
808018h	DMA 1 Transfer Counter
808020h	Timer 0 Global Control
808024h	Timer 0 Counter
808028h	Timer 0 Period
808030h	Timer 1 Global Control
808034h	Timer 1 Counter
808038h	Timer 1 Period Register
808040h	Serial Port Global Control
808042h	FSX/DX/CLKX Port Control
808043h	FSR/DR/CLKR Port Control
808044h	R/X Timer Control
808045h	R/X Timer Counter
808046h	R/X Timer Period
808048h	Data Transmit
80804Ch	Data Receive
808050h	Reserved
80805Fh	
808060h	IOSTRB-Bus Control
808064h	STRB0-Bus Control
808068h	STRB1-Bus Control
808069h	Reserved
8097FFh	

Figure 9. Peripheral-Bus Memory-Mapped Registers

interrupts

To reduce external logic and simplify the interface, the external interrupts can be either edge- or level-triggered. Unlike the fixed interrupt-trap vector-table location of the 320C30 and 320C31 devices, the SM320C32-EP has a user-relocatable interrupt-trap vector table. The interrupt-trap vector table must start on a 256-word boundary. The interrupt and trap vector locations memory mapping is illustrated in Figure 10. The reset vector is fixed to address 0h as shown in Figure 8.

EA (ITTP) + 00h	Reserved
EA (ITTP) + 01h	INT0
EA (ITTP) + 02h	INT1
EA (ITTP) + 03h	INT2
EA (ITTP) + 04h	INT3
EA (ITTP) + 05h	XINT0
EA (ITTP) + 06h	RINT0
EA (ITTP) + 07h	Reserved
EA (ITTP) + 08h	Reserved
EA (ITTP) + 09h	TINT0
EA (ITTP) + 0Ah	TINT1
EA (ITTP) + 0Bh	DINT0
EA (ITTP) + 0Ch	DINT1
EA (ITTP) + 0Dh	Reserved
EA (ITTP) + 1Fh	Reserved
EA (ITTP) + 20h	TRAP0
	⋮
	⋮
	⋮
EA (ITTP) + 3Bh	TRAP27
EA (ITTP) + 3Ch	TRAP28
EA (ITTP) + 3Dh	TRAP29
EA (ITTP) + 3Eh	TRAP30
EA (ITTP) + 3Fh	TRAP31

Figure 10. Reset, Interrupt, and Trap Vector/Branches Memory-Map Locations

SM320C32-EP DIGITAL SIGNAL PROCESSOR

SGUS038 – AUGUST 2002

absolute maximum ratings over specified temperature ranges (unless otherwise noted)†

Supply voltage range, V_{CC} (see Note 1)	-0.3 V to 7 V
Input voltage range	-0.3 V to 7 V
Output voltage range, V_O	-0.3 V to 7 V
Continuous power dissipation (see Note 2)	1.95 W
Operating case temperature, T_C	-55°C to 125°C
Storage temperature, T_{stg}	-55°C to 150°C

† Stresses beyond those listed under “absolute maximum ratings” may cause permanent damage to the device. These are stress ratings only, and functional operation of the device at these or any other conditions beyond those indicated under “recommended operating conditions” is not implied. Exposure to absolute-maximum-rated conditions for extended periods may affect device reliability.

NOTES: 1. All voltage values are with respect to V_{SS} .

2. This value calculated for the C32-40. Actual operating power is less. This value was obtained under specially produced worst-case test conditions which are not sustained during normal device operation. These conditions consist of continuous parallel writes of a checkerboard pattern to the external bus at the maximum rate possible. See normal (I_{DD}) current specification in the electrical characteristics table and see the *Calculation of TMS320C30 Power Dissipation Application Report* (literature number SPRA020).

recommended operating conditions (see Note 3)

	MIN	NOM‡	MAX	UNIT
V_{DD} Supply voltage (DV_{DD} , V_{DDL})	4.75	5	5.25	V
V_{SS} Supply voltage (CV_{SS} , V_{SSL} , IV_{SS} , DV_{SS} , V_{SUBS})		0		V
V_{IH} High-level input voltage	CLKIN	2.6	$V_{DD} + 0.3^*$	V
	All other inputs	2	$V_{DD} + 0.3^*$	V
V_{IL} Low-level input voltage	-0.3*		0.8	V
I_{OH} High-level output current			-300	μA
I_{OL} Low-level output current			2	mA
T_C Operating case temperature (see Note 4)	-55		125	°C

* This parameter is not production tested.

‡ All nominal values are at $V_{DD} = 5$ V, T_A (ambient-air temperature) = 25°C.

NOTE 3: All input and output voltage levels are TTL compatible.

NOTE 4: T_C MAX at maximum rated operating conditions at any point on case. T_C MIN at initial (time zero) power-up.

electrical characteristics over recommended ranges of supply voltage (unless otherwise noted) ‡

PARAMETER		TEST CONDITIONS	MIN	NOM	MAX	UNIT	
V_{OH}	High-level output voltage	$V_{DD} = \text{MIN}$, $I_{OH} = \text{MAX}$	2.4	3		V	
V_{OL}	Low-level output voltage	$V_{DD} = \text{MIN}$, $I_{OL} = \text{MAX}$		0.3	0.8	V	
I_{OZ}	High-impedance state output current	$V_{DD} = \text{MAX}$	-20		20	μA	
I_I	Input current	$V_I = V_{SS}$ to V_{DD}	-10		10	μA	
I_{DD}	Supply current (see Note 5)	$f_x = 50$ MHz‡	$T_A = 25$ °C, $f_x = \text{MAX}‡$	$V_{DD} = \text{MAX}$,	200	425	mA
		$f_x = 60$ MHz‡			225	475	
		Standby	IDLE2,	CLKIN shut off	50		μA
C_I	Input capacitance	CLKIN			25	pF	
		All other inputs			15*		
C_O	Output capacitance				20*	pF	

* This parameter is not production tested.

‡ All nominal values are at $V_{DD} = 5$ V, $T_A = 25$ °C.

‡ f_x is the input clock frequency.

NOTE 5: Actual operating current is less than this maximum value (see Note 2).



PARAMETER MEASUREMENT INFORMATION

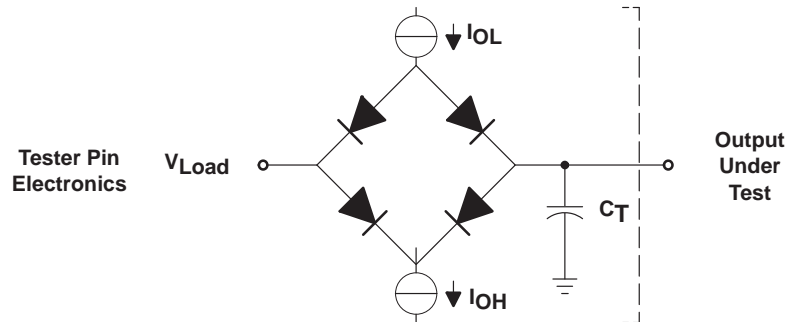

Where: I_{OL} = 2 mA (all outputs)
 I_{OH} = 300 μ A (all outputs)
 V_{Load} = Selected to emulate 50- Ω termination (typical value = 1.54 V)
 C_T = 80-pF typical load-circuit capacitance

Figure 11. Test Load Circuit

signal-transition levels

TTL-level outputs are driven to a minimum logic-high level of 2.4 V and to a maximum logic-low level of 0.6 V. Output transition times are specified in the following paragraph.

For a high-to-low transition on a TTL-compatible output signal, the level at which the output is said to be no longer high is 2 V and the level at which the output is said to be low is 1 V. For a low-to-high transition, the level at which the output is said to be no longer low is 1 V and the level at which the output is said to be high is 2 V (see Figure 12).

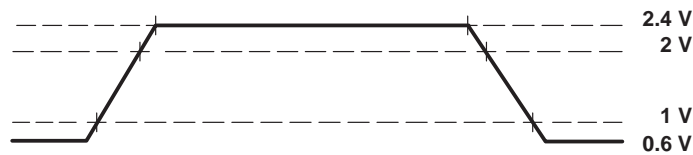

Figure 12. TTL-Level Outputs

Transition times for TTL-compatible inputs are specified as follows. For a high-to-low transition on an input signal, the level at which the input is said to be no longer high is 2 V and the level at which the input is said to be low is 0.8 V. For a low-to-high transition on an input signal, the level at which the input is said to be no longer low is 0.8 V and the level at which the input is said to be high is 2 V (see Figure 13).



Figure 13. TTL-Level Inputs

PARAMETER MEASUREMENT INFORMATION (CONTINUED)

timing parameter symbology

Timing parameter symbols used in this document are in accordance with JEDEC Standard 100-A. Unless otherwise noted, in order to shorten the symbols, pin names and other related terminology have been abbreviated as follows:

- A A23–A0 when the physical-memory-width-bit field of the $\overline{\text{STRBx}}$ control register is set to 32 bits
A23–A0 and $\overline{\text{STRBx_B3/A_1}}$ when the physical-memory-width-bit field of the $\overline{\text{STRBx}}$ control register is set to 16 bits
- CI CLKIN
- RDY $\overline{\text{RDY}}$
- D D(31–0)
- H H1, H3
- IOS $\overline{\text{IOSTRB}}$
- P $t_{c(H)}$
- Q $t_{c(Cl)}$
- RW R/\overline{W}
- S $\overline{\text{STRBx_B(3–0)}}$ when the physical-memory-width-bit field of the $\overline{\text{STRBx}}$ control register is set to 32 bits
 $\overline{\text{STRBx_B(1–0)}}$ when the physical-memory-width-bit field of the $\overline{\text{STRBx}}$ control register is set to 16 bits
 $\overline{\text{STRBx_B0}}$ when the physical-memory-width-bit field of the $\overline{\text{STRBx}}$ control register is set to 8 bits
- XF XF0 or XF1



timings for CLKIN [Q = t_c(Cl)] (see Figure 14)

NO.		TEST CONDITIONS	320C32-50		320C32-60		UNIT
			MIN	MAX	MIN	MAX	
1	t _f (Cl) [†] Fall time, CLKIN			5*		4*	ns
2	t _w (CLL) [†] Pulse duration, CLKIN low	Q = min	7		6		ns
3	t _w (CIH) Pulse duration, CLKIN high	Q = min	8 [†]		6 [†]		ns
4	t _r (Cl) [†] Rise time, CLKIN			5*		4*	ns
5	t _c (Cl) [†] Cycle time, CLKIN		20	303	16.67	303	ns

[†] Minimum CLKIN high-pulse duration at 3.3 MHz is 10 ns.

* This parameter is not production tested.

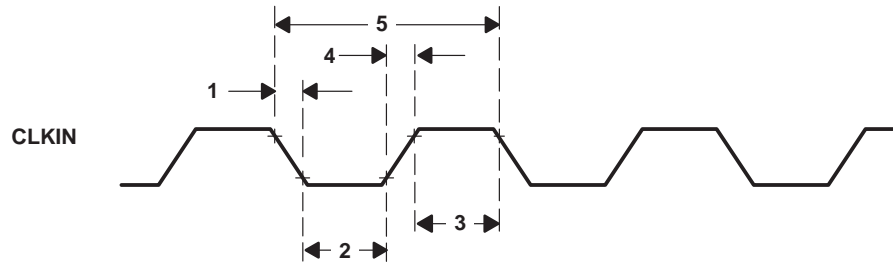

Figure 14. CLKIN Timing

switching characteristics for H1 and H3 over recommended operating conditions (unless otherwise noted) (see Figure 15)

NO.	PARAMETER	TEST CONDITIONS	320C32-50		320C32-60		UNIT
			MIN	MAX	MIN	MAX	
6	t _f (H) Fall time, H1/H3			3		3	ns
7	t _w (HL) Pulse duration, H1/H3 low		Q-5		Q-4		ns
8	t _w (HH) Pulse duration, H1/H3 high		Q-6		Q-5		ns
9	t _r (H) Rise time, H1/H3			3		3	ns
9.1	t _d (HL-HH) Delay time, H1/H3 low to H1/H3 high		0*	4	0*	4	ns
10	t _c (H) Cycle time, H1/H3		40	606	33.33	606	ns

* This parameter is not production tested.

SM320C32-EP DIGITAL SIGNAL PROCESSOR

SGUS038 – AUGUST 2002

switching characteristics for H1 and H3 (see Figure 15) (continued)

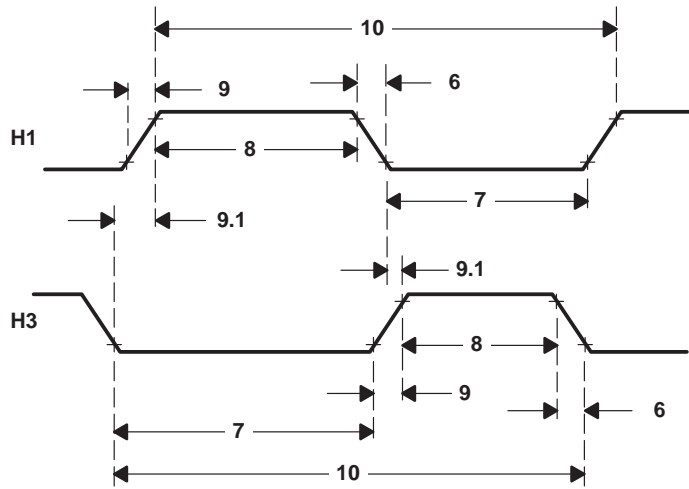
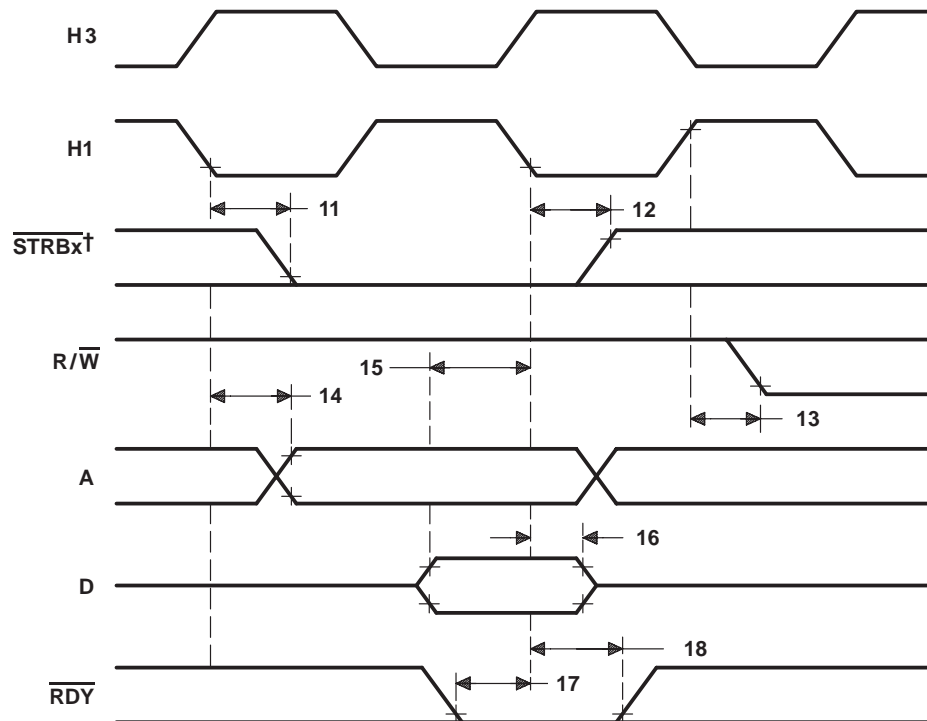

Figure 15. H1/H3 Timing

memory-read-cycle and memory-write-cycle timing ($\overline{\text{STRBx}}$) (see Figure 16 and Figure 17)

NO.		320C32-50		320C32-60		UNIT
		MIN	MAX	MIN	MAX	
11	$t_{d(H1L-SL)}$ Delay time, H1 low to $\overline{\text{STRBx}}$ low	0*	9	0*	7	ns
12	$t_{d(H1L-SH)}$ Delay time, H1 low to $\overline{\text{STRBx}}$ high	0*	9	0*	7	ns
13	$t_{d(H1H-RWL)}$ Delay time, H1 high to $\overline{\text{R/W}}$ low (read)	0*	9	0*	8	ns
14	$t_{d(H1L-A)}$ Delay time, H1 low to A valid	0*	9	0*	7	ns
15	$t_{su(D)R}$ Setup time, D valid before H1 low (read)	10		10		ns
16	$t_h(D)R$ Hold time, D after H1 low (read)	0		0		ns
17	$t_{su(RDY)}$ Setup time, $\overline{\text{RDY}}$ before H1 low	19		17		ns
18	$t_h(RDY)$ Hold time, $\overline{\text{RDY}}$ after H1 low	0		0		ns
19	$t_{d(H1H-RWH)}$ Delay time, H1 high to $\overline{\text{R/W}}$ high (write)		9		8	ns
20	$t_v(D)W$ Valid time, D after H1 low (write)		14		12	ns
21	$t_h(D)W$ Hold time, D after H1 high (write)	0*		0*		ns
22	$t_{d(H1H-A)}$ Delay time, H1 high to A valid on back-to-back write cycles		9		8	ns

* This parameter is not production tested.



NOTE A: $\overline{\text{STRBx}}$ remains low during back-to-back operations.

Figure 16. Memory-Read-Cycle Timing

SM320C32-EP DIGITAL SIGNAL PROCESSOR

SGUS038 – AUGUST 2002

memory-read-cycle and memory-write-cycle timing ($\overline{\text{STRBx}}$) (see Figure 16 and Figure 17)
(continued)

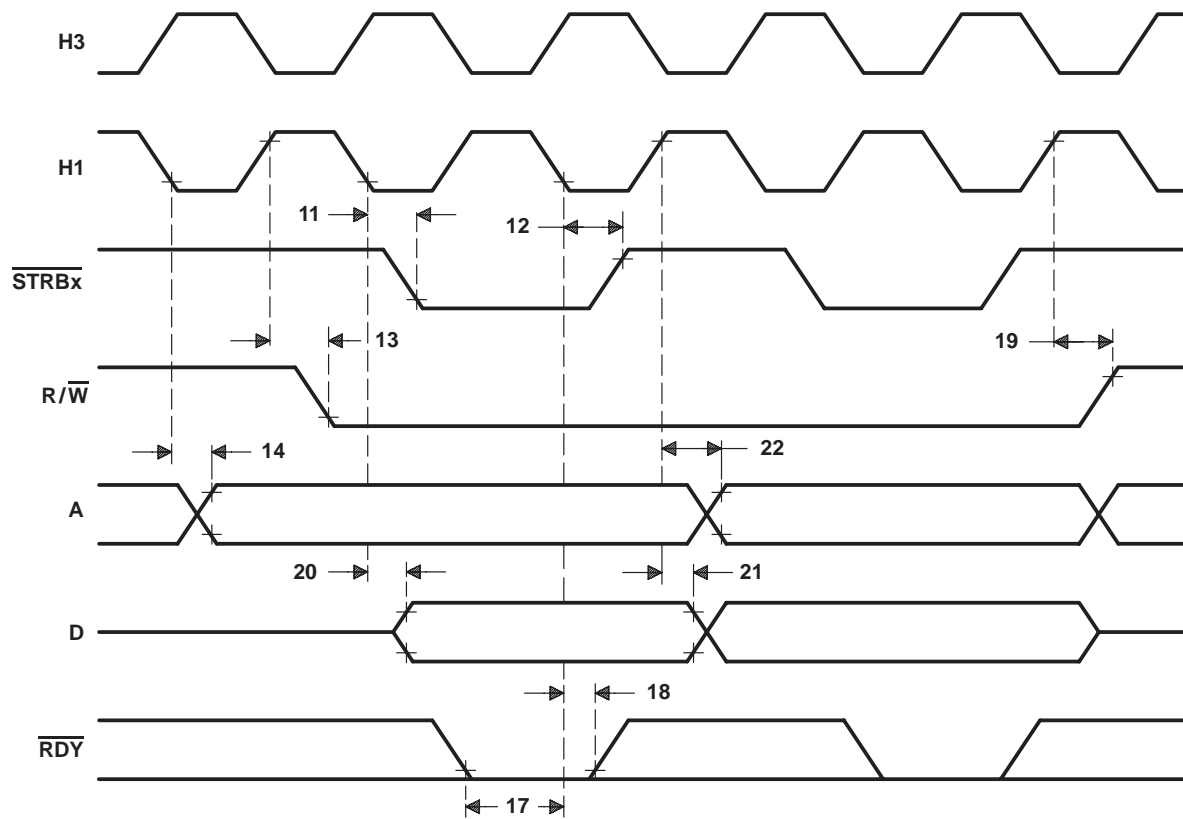
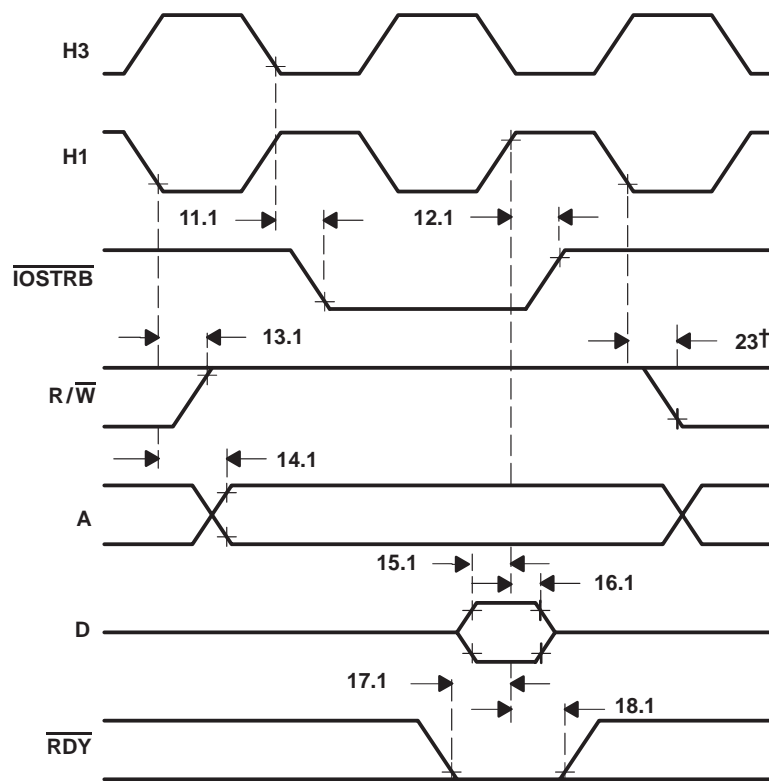

Figure 17. Memory-Write-Cycle Timing

memory-read-cycle timing using $\overline{\text{IOSTRB}}$ (see Figure 18)

NO.		320C32-50		320C32-60		UNIT
		MIN	MAX	MIN	MAX	
11.1	$t_{d(\text{H3L-IOSL})}$ Delay time, H3 low to $\overline{\text{IOSTRB}}$ low	0*	9	0*	8	ns
12.1	$t_{d(\text{H3L-IOSH})}$ Delay time, H3 low to $\overline{\text{IOSTRB}}$ high	0*	9	0*	8	ns
13.1	$t_{d(\text{H1L-RWL})}$ Delay time, H1 low to R/ $\overline{\text{W}}$ high	0*	9	0*	8	ns
14.1	$t_{d(\text{H1L-A})}$ Delay time, H1 low to A valid	0*	9	0*	8	ns
15.1	$t_{\text{su}(\text{D})\text{R}}$ Setup time, D before H1 high	10		9		ns
16.1	$t_{\text{h}(\text{D})\text{R}}$ Hold time, D after H1 high	0		0		ns
17.1	$t_{\text{su}(\text{RDY})}$ Setup time, $\overline{\text{RDY}}$ before H1 high	8		7		ns
18.1	$t_{\text{h}(\text{RDY})}$ Hold time, $\overline{\text{RDY}}$ after H1 high	0		0		ns

* This parameter is not production tested.



NOTE A: See Figure 19 and accompanying table

Figure 18. Memory-Read-Cycle Timing Using $\overline{\text{IOSTRB}}$

SM320C32-EP DIGITAL SIGNAL PROCESSOR

SGUS038 – AUGUST 2002

memory-write-cycle timing using $\overline{\text{IOSTRB}}$ (see Figure 19)

NO.		320C32-50		320C32-60		UNIT
		MIN	MAX	MIN	MAX	
23	$t_{d(H1L-RWH)}$ Delay time, H1 low to R/ \overline{W} low	0*	9	0*	8	ns
24	$t_{v(D)W}$ Valid time, D after H1 high		14		12	ns
25	$t_{h(D)W}$ Hold time, D after H1 low	0		0		ns

* This parameter is not production tested.

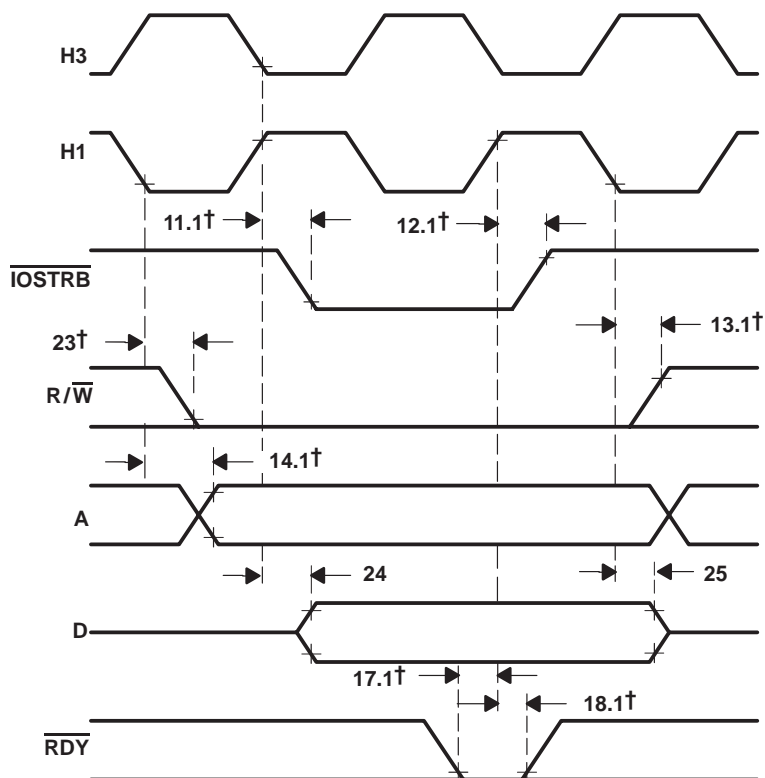

NOTE A: See Figure 18 and accompanying table

Figure 19. Memory-Write-Cycle Timing Using $\overline{\text{IOSTRB}}$

timing for XF0 and XF1 when executing LDFI or LDII (see Figure 20)

NO.		320C32-50		320C32-60		UNIT
		MIN	MAX	MIN	MAX	
38	$t_{d(H3H-XF0L)}$ Delay time, H3 high to XF0 low		12		11	ns
39	$t_{su(XF1)}$ Setup time, XF1 before H1 low	9		8		ns
40	$t_{h(XF1)}$ Hold time, XF1 after H1 low	0		0		ns

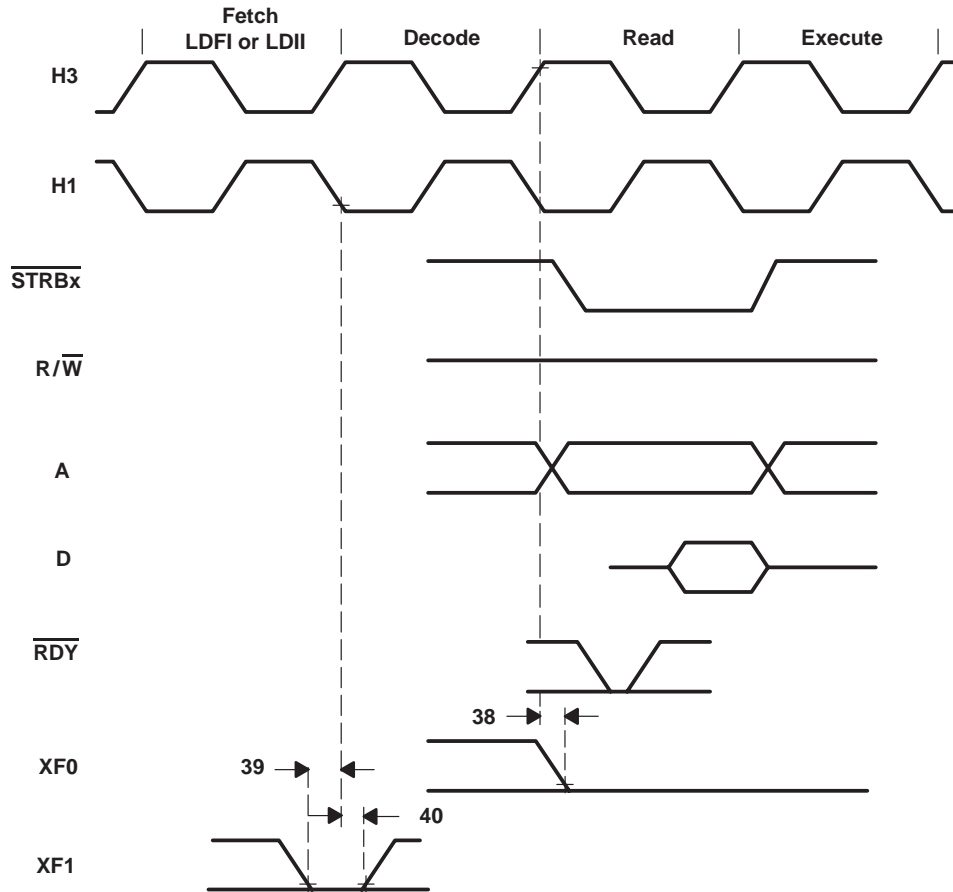

Figure 20. XF0 and XF1 When Executing LDFI or LDII

SM320C32-EP DIGITAL SIGNAL PROCESSOR

SGUS038 – AUGUST 2002

timing for XF0 when executing STFI or STII† (see Figure 21)

NO.		320C32-50		320C32-60		UNIT
		MIN	MAX	MIN	MAX	
41	$t_d(H3H-XF0H)$ Delay time, H3 high to XF0 high		12		11	ns

† XF0 is always set high at the beginning of the execute phase of the interlock-store instruction. When no pipeline conflicts occur, the address of the store is driven at the beginning of the execute phase of the interlock-store instruction. However, if a pipeline conflict prevents the store from executing, the address of the store is not driven until the store can execute.

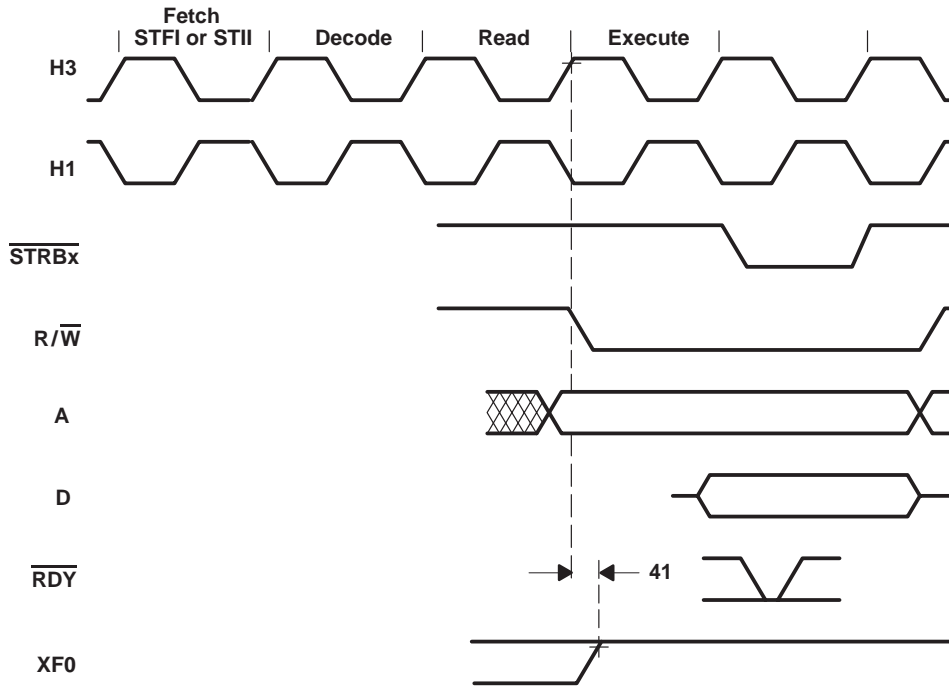

Figure 21. XF0 When Executing a STFI or STII

timing for XF0 and XF1 when executing SIGI (see Figure 22)

NO.		320C32-50		320C32-60		UNIT
		MIN	MAX	MIN	MAX	
41.1	$t_{d(H3H-XF0L)}$ Delay time, H3 high to XF0 low		12		11	ns
42	$t_{d(H3H-XF0H)}$ Delay time, H3 high to XF0 high		12		11	ns
43	$t_{su}(XF1)$ Setup time, XF1 before H1 low	9		8		ns
44	$t_h(XF1)$ Hold time, XF1 after H1 low	0		0		ns

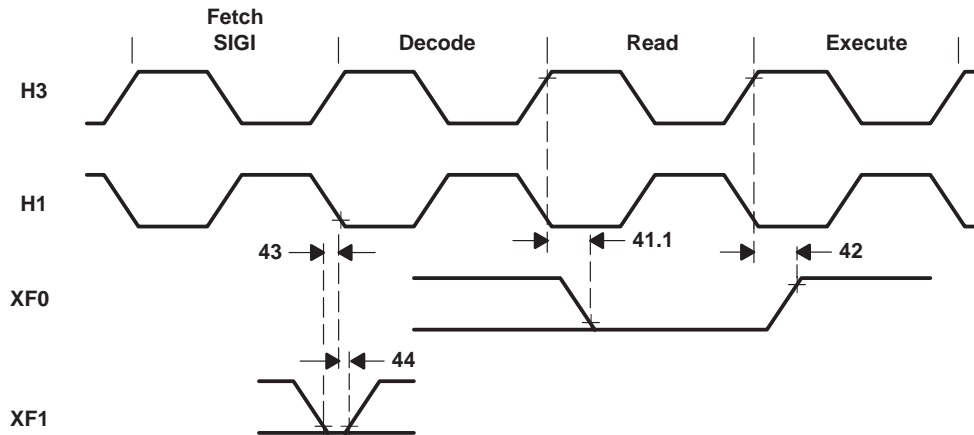
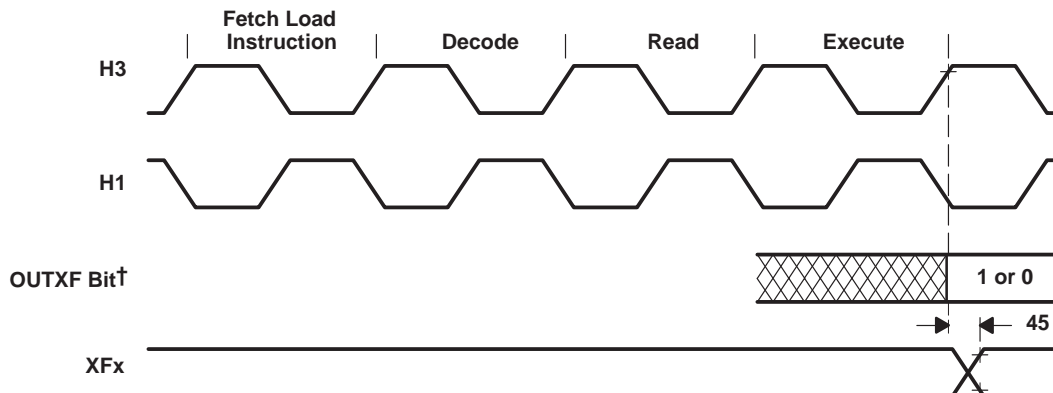

Figure 22. XF0 and XF1 When Executing SIGI

timing for loading XF register when configured as an output pin (see Figure 23)

NO.		320C32-50		320C32-60		UNIT
		MIN	MAX	MIN	MAX	
45	$t_{v(H3H-XF)}$ Valid time, H3 high to XF valid		12		11	ns



NOTE A: OUTXFx represents either bit 2 or 6 of the IOF register.

Figure 23. Loading XF Register When Configured as an Output Pin

SM320C32-EP DIGITAL SIGNAL PROCESSOR

SGUS038 – AUGUST 2002

timing of XF changing from output to input mode (see Figure 24)

NO.		320C32-50		320C32-60		UNIT
		MIN	MAX	MIN	MAX	
46	$t_h(H3H-XF01)$ Hold time, XF after H3 high		12*		11*	ns
47	$t_{su}(XF)$ Setup time, XF before H1 low	9		8		ns
48	$t_h(XF)$ Hold time, XF after H1 low	0		0		ns

* This parameter is not production tested.

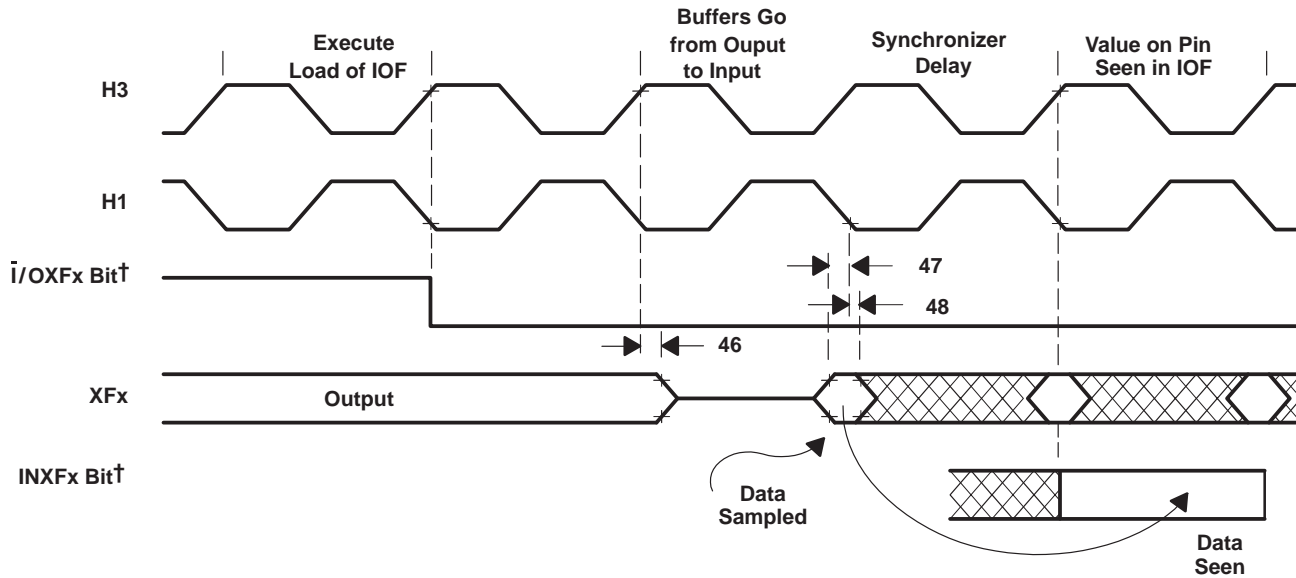

NOTE A: \bar{I}/OXF_x represents either bit 1 or bit 5 of the IOF register, and $INXF_x$ represents either bit 3 or bit 7 of the IOF register.

Figure 24. Change of XF From Output to Input Mode

timing of XF changing from input to output mode (see Figure 25)

NO.		320C32-50		320C32-60		UNIT
		MIN	MAX	MIN	MAX	
49	$t_d(H3H-XFIO)$ Delay time, H3 high to XF switching from input to output		17		15	ns

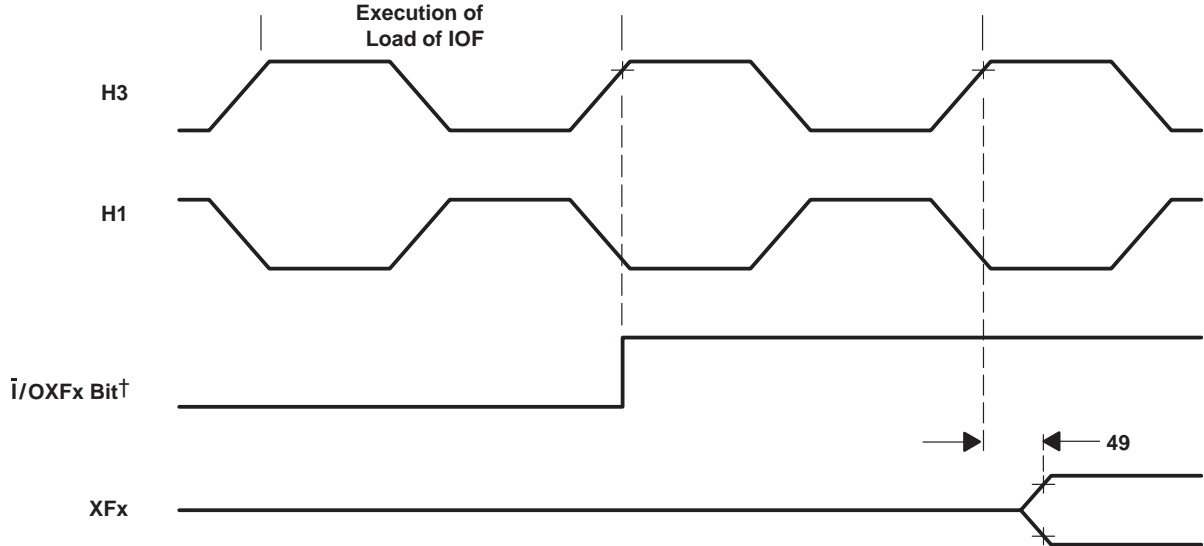

NOTE A: $\bar{i}/OxFx$ represents either bit 1 or bit 5 of the IOF register.

Figure 25. Change of XF From Input to Output Mode

SM320C32-EP DIGITAL SIGNAL PROCESSOR

SGUS038 – AUGUST 2002

timing for $\overline{\text{RESET}}$ [$Q = t_{c(CI)}$] (see Figure 26)

NO.		320C32-50		320C32-60		UNIT
		MIN	MAX	MIN	MAX	
50	$t_{su}(\overline{\text{RESET}})$	10	Q^*	17	Q^*	ns
51	$t_d(\text{CLKINH-H1H})$	2	10	2	10	ns
52	$t_d(\text{CLKINH-H1L})$	2	10	2	10	ns
53	$t_{su}(\overline{\text{RESETH-H1L}})$	7		6		ns
54	$t_d(\text{CLKINH-H3L})$	2	10	2	10	ns
55	$t_d(\text{CLKINH-H3H})$	2	10	2	10	ns
56	$t_{dis}(\text{H1H-D})$		12*		11*	ns
57	$t_{dis}(\text{H3HL-A})$		9*		9*	ns
58.1	$t_d(\text{H3H-CONTROLH})$		8*		7*	ns
58.2	$t_d(\text{H1H-RWH})$		8*		7*	ns
59	$t_d(\text{H1H-IACKH})$		8*		7*	ns
60	$t_{dis}(\overline{\text{RESETHL-ASYNCH}})$		17*		14*	ns

* This parameter is not production tested.

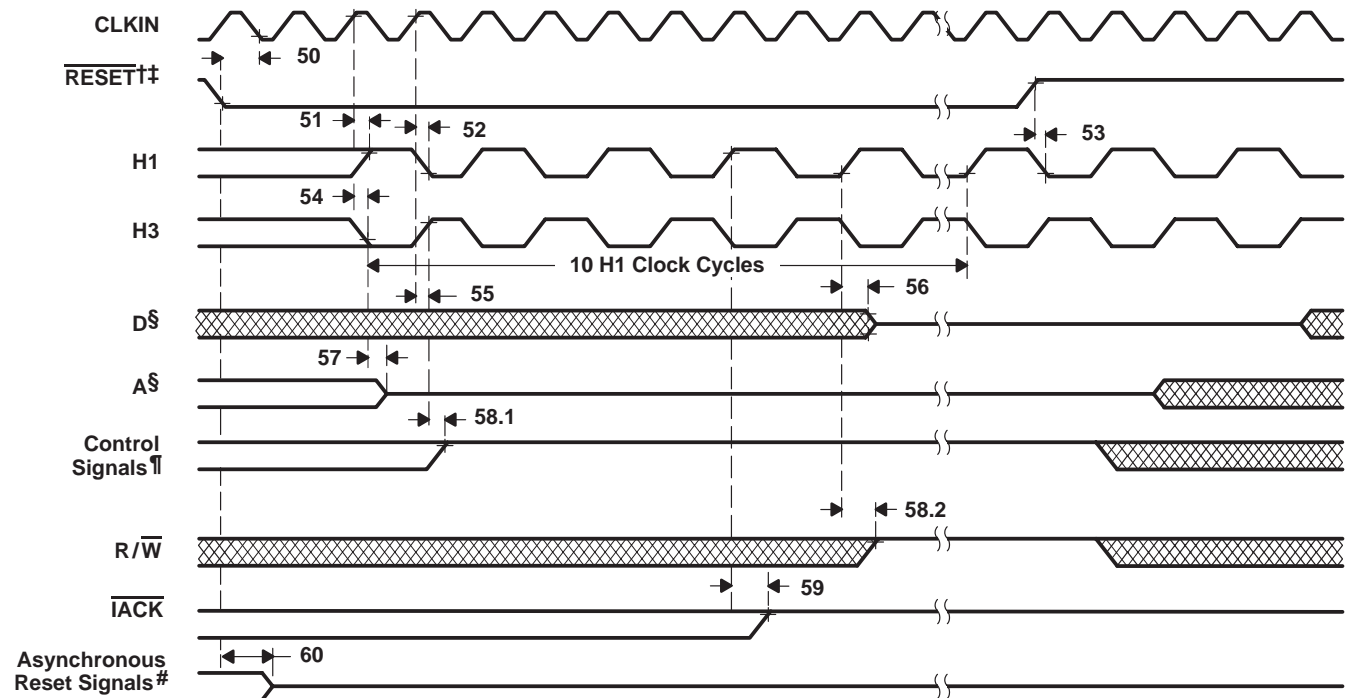

- NOTES:
- $\overline{\text{RESET}}$ is an asynchronous input and can be asserted at any point during a clock cycle. If the specified timings are met, the exact sequence shown occurs; otherwise, an additional delay of one clock cycle can occur.
 - The $\overline{\text{R/W}}$ output is placed in the high-impedance state during reset and can be provided with a resistive pullup, nominally 18–22 k Ω , if undesirable spurious writes can occur when these outputs go low.
 - In microprocessor mode ($\text{MCBL} / \overline{\text{MP}} = 0$), reset vector is fetched twice with seven software wait states each. In microcomputer mode ($\text{MCBL} / \overline{\text{MP}} = 1$), the reset vector is fetched two times, with no software wait states.
 - Control signals include $\overline{\text{STRBx}}$ and $\overline{\text{IOSTRB}}$.
 - Asynchronous reset signals include XF0/1 , CLKX0 , DX0 , FSX0 , CLKR0 , DR0 , FSR0 , and TCLKx .

Figure 26. $\overline{\text{RESET}}$ Timing



timing for $\overline{\text{INT3}} - \overline{\text{INT0}}$ interrupt response [$P = t_{c(H)}$] (see Figure 27)

NO.		320C32-50		320C32-60		UNIT
		MIN	MAX	MIN	MAX	
61	$t_{su(\text{INT})}$ Setup time, $\overline{\text{INT3}} - \overline{\text{INT0}}$ before H1 low	10		8		ns
62.1	$t_w(\text{INT})$ Pulse duration of interrupt to assure only one interrupt seen for level-triggered interrupts	P	2P*	P	2P*	ns
62.2	$t_w(\text{INT})$ Pulse duration of interrupt for edge-triggered interrupts	P*		P*		ns

* This parameter is not production tested.

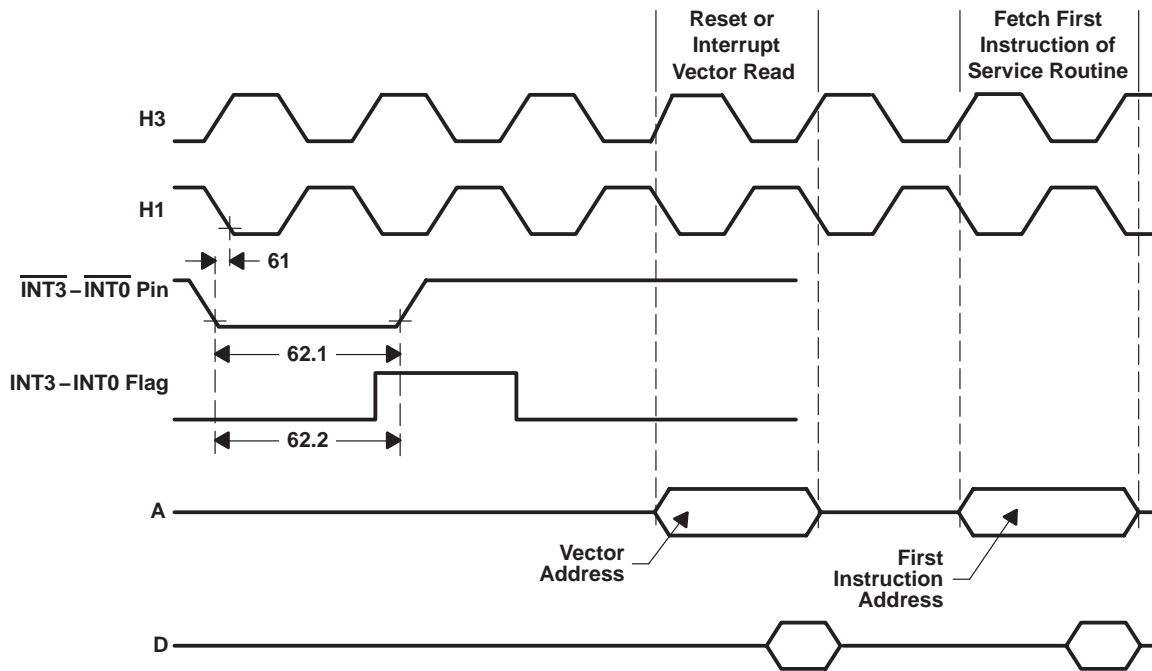

Figure 27. $\overline{\text{INT3}} - \overline{\text{INT0}}$ Interrupt-Response Timing

SM320C32-EP DIGITAL SIGNAL PROCESSOR

SGUS038 – AUGUST 2002

timing for $\overline{\text{IACK}}$ (see Notes 6, 7, and Figure 28)

NO.		320C32-50		320C32-60		UNIT
		MIN	MAX	MIN	MAX	
63	$t_{d(H1H-IACKL)}$ Delay time, H1 high to $\overline{\text{IACK}}$ low		7		6	ns
64	$t_{d(H1H-IACKH)}$ Delay time, H1 high to $\overline{\text{IACK}}$ high		7		6	ns

- NOTES:
- $\overline{\text{IACK}}$ is active for the entire duration of the bus cycle and is extended if the bus cycle utilizes wait states.
 - $\overline{\text{IACK}}$ goes active on the first half-cycle (H1 rising) of the decode phase of the IACK instruction and goes inactive at the first half-cycle (H1 rising) of the read phase of the IACK instruction. Because of pipeline conflicts, $\overline{\text{IACK}}$ remains low for one cycle even if the decode phase of the IACK instruction is extended.

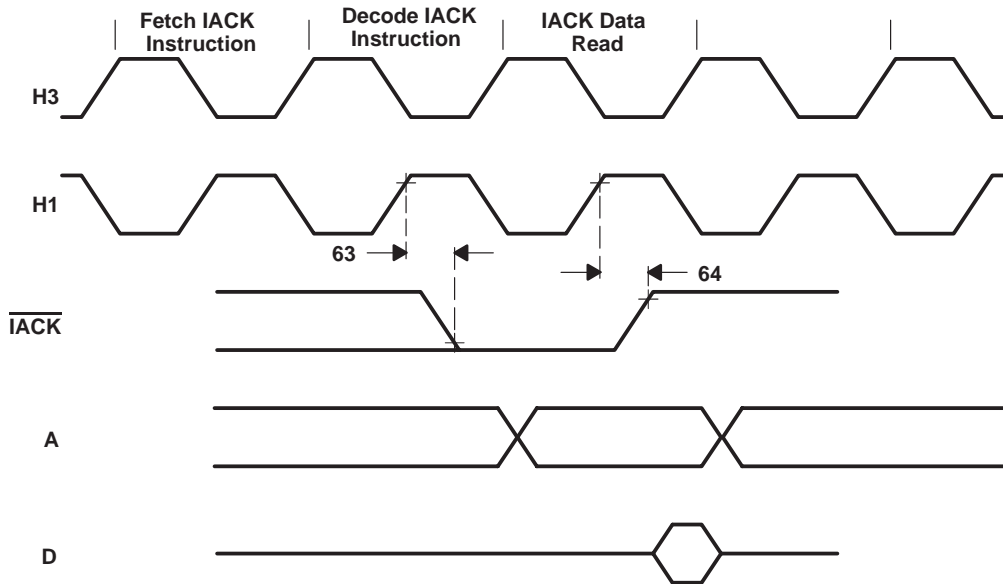

Figure 28. $\overline{\text{IACK}}$ Timing

serial-port timing

serial-port timing [P = t_{c(H)}] (see Figure 29 and Figure 30)

NO.		320C32-50		320C32-60		UNIT	
		MIN	MAX	MIN	MAX		
65	t _{d(H1-SCK)} Delay time, H1 high to internal CLKX/R high/low	10		8		ns	
66	t _{c(SCK)} Cycle time, CLKX/R	CLKX/R ext	2.6P	2.6P		ns	
		CLKX/R int	2P	(2 ³²)P			
67	t _{w(SCK)} Pulse duration, CLKX/R high/low	CLKX/R ext	P + 10		P + 10		ns
		CLKX/R int	[t _{c(SCK)/2]-5}	[t _{c(SCK)/2]+5}	[t _{c(SCK)/2]-5}	[t _{c(SCK)/2]+5}	
68	t _{r(SCK)} Rise time, CLKX/R	6		5		ns	
69	t _{f(SCK)} Fall time, CLKX/R	6		5		ns	
70	t _{d(DX)} Delay time, CLKX to DX valid	CLKX ext	24		20		ns
		CLKX int	16		15		
71	t _{su(DR)} Setup time, DR before CLKR low	CLKR ext	9		8		ns
		CLKR int	17		15		
72	t _{h(DR)} Hold time, DR from CLKR low	CLKR ext	7		6		ns
		CLKR int	0		0		
73	t _{d(FSX)} Delay time, CLKX to internal FSX high/low	CLKX ext	22		20		ns
		CLKX int	15		14		
74	t _{su(FSR)} Setup time, FSR before CLKR low	CLKR ext	7		6		ns
		CLKR int	7		6		
75	t _{h(FS)} Hold time, FSX/R input from CLKX/R low	CLKX/R ext	7		6		ns
		CLKX/R int	0		0		
76	t _{su(FSX)} Setup time, external FSX before CLKX high	CLKX ext	8-P	[t _{c(SCK)/2]-10*}	8-P	[t _{c(SCK)/2]-10*}	ns
		CLKX int	21-P	t _{c(SCK)/2*}	21-P	t _{c(SCK)/2*}	
77	t _{d(CH-DX)V} Delay time, CLKX to first DX bit, FSX precedes CLKX high	CLKX ext	24*		20*		ns
		CLKX int	14*		12*		
78	t _{d(FSX-DX)V} Delay time, FSX to first DX bit, CLKX precedes FSX	24*		20*		ns	
79	t _{d(DXZ)} Delay time, CLKX high to DX in the high-impedance state following last data bit	14*		12*		ns	

* This parameter is not production tested.

serial-port timing

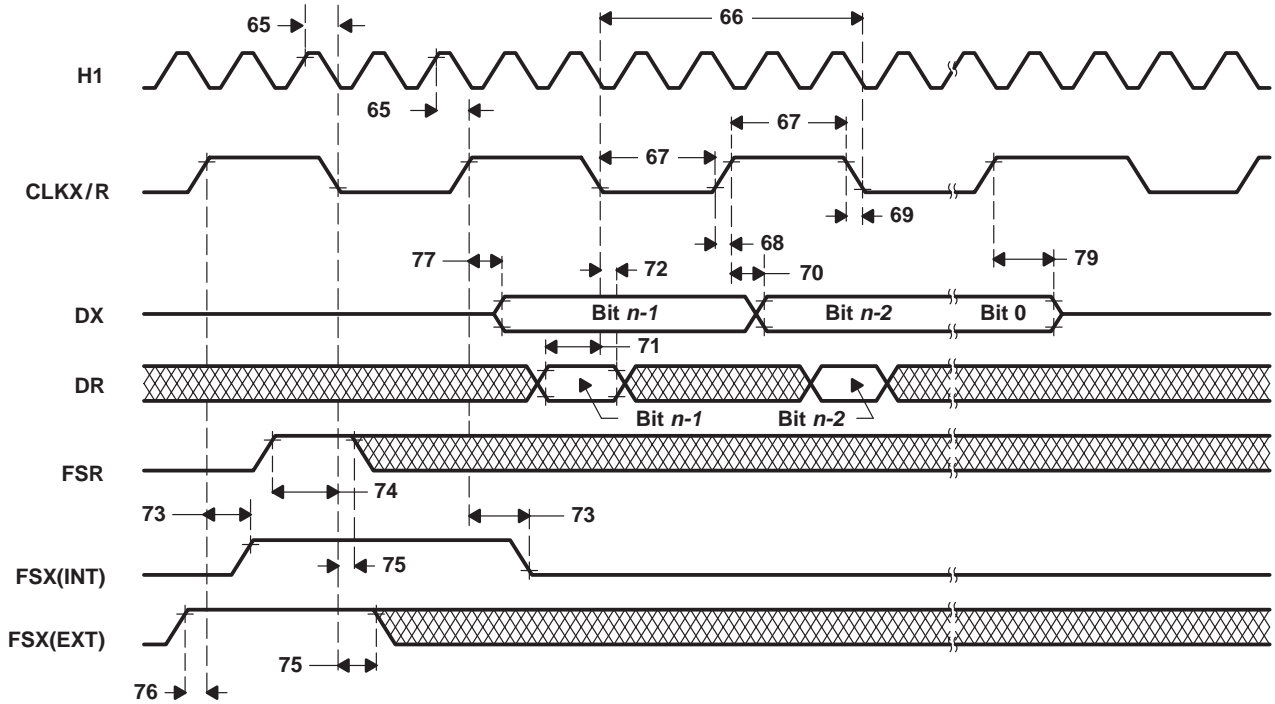

- NOTES: A. Timing diagrams show operations with CLKXP = CLKRP = FSXP = FSRP = 0.
 B. Timing diagrams depend upon the length of the serial-port word, where $n = 8, 16, 24,$ or 32 bits, respectively.

Figure 29. Fixed Data-Rate-Mode Timing

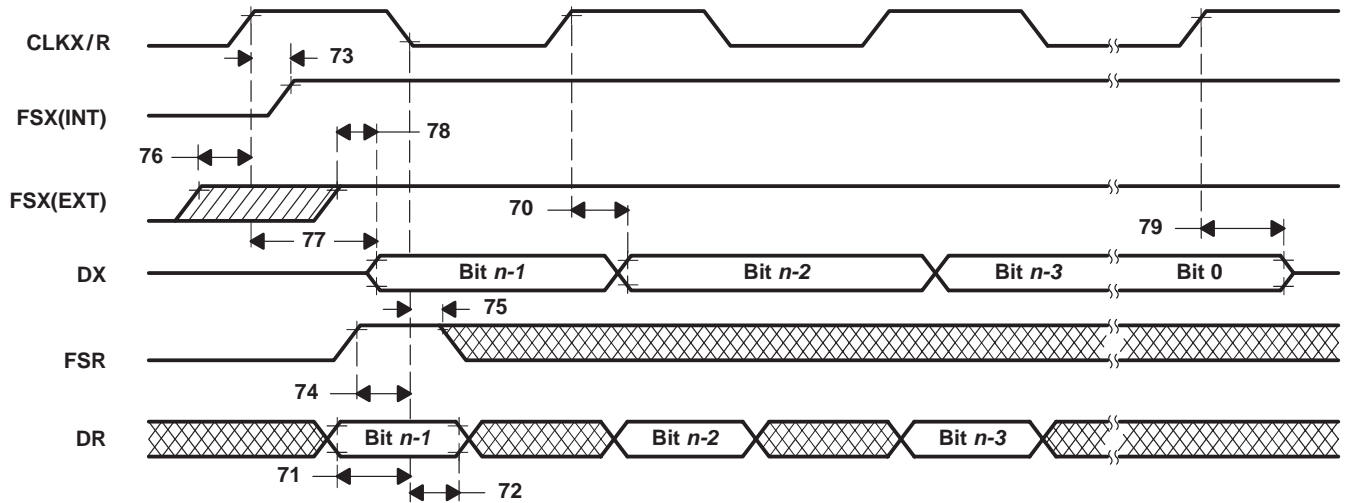

- NOTES: A. Timing diagrams show operation with CLKXP = CLKRP = FSXP = FSRP = 0.
 B. Timing diagrams depend upon the length of the serial-port word, where $n = 8, 16, 24,$ or 32 bits, respectively.
 C. The timings that are not specified expressly for the variable data-rate mode are the same as those that are specified for the fixed data-rate mode.

Figure 30. Variable Data-Rate-Mode Timing

timing for $\overline{\text{HOLD}}/\overline{\text{HOLDA}}$ [$P = t_{c(H)}$] (see Note 8 and Figure 31)

NO.		320C32-50		320C32-60		UNIT
		MIN	MAX	MIN	MAX	
80	$t_{su}(\overline{\text{HOLD}})$ Setup time, $\overline{\text{HOLD}}$ before H1 low	10		8		ns
81	$t_v(\overline{\text{HOLDA}})$ Valid time, $\overline{\text{HOLDA}}$ after H1 low	0*	7	0*	6	ns
82	$t_w(\overline{\text{HOLD}})$ Pulse duration, $\overline{\text{HOLD}}$ low	2P		2P		ns
83	$t_w(\overline{\text{HOLDA}})$ Pulse duration, $\overline{\text{HOLDA}}$ low	P-5*		P-5*		ns
84	$t_d(\text{H1L-SH})\text{H}$ Delay time, H1 low to $\overline{\text{STRBx}}$ high for a $\overline{\text{HOLD}}$	0*	7*	0*	6*	ns
84.1	$t_d(\text{H1H-IO})\text{SH}$ Delay time, H1 high to $\overline{\text{IOSTRB}}$ high for a $\overline{\text{HOLD}}$	0*	7*	0*	6*	ns
85	$t_{dis}(\text{H1L-S})$ Disable time, H1 low to $\overline{\text{STRBx}}$ or $\overline{\text{IOSTRB}}$ (in the high-impedance state)	0*	8*	0*	7*	ns
86	$t_{en}(\text{H1L-S})$ Enable time, H1 low to $\overline{\text{STRBx}}$ or $\overline{\text{IOSTRB}}$ active	0*	7*	0*	6*	ns
87	$t_{dis}(\text{H1L-RW})$ Disable time, H1 low to $\overline{\text{R/W}}$ in the high-impedance state	0*	8*	0*	7*	ns
88	$t_{en}(\text{H1L-RW})$ Enable time, H1 low to $\overline{\text{R/W}}$ (active)	0*	7*	0*	6*	ns
89	$t_{dis}(\text{H1L-A})$ Disable time, H1 low to A in the high-impedance state	0*	8*	0*	7*	ns
90	$t_{en}(\text{H1L-A})$ Enable time, H1 low to A valid	0*	12*	0*	11*	ns
91	$t_{dis}(\text{H1H-D})$ Disable time, H1 high to D disabled in the high-impedance state	0*	8*	0*	7*	ns

* This parameter is not production tested.

NOTE 8: $\overline{\text{HOLD}}$ is an asynchronous input and can be asserted at any point during a clock cycle. If the specified timings are met, the exact sequence shown occurs; otherwise, an additional delay of one clock cycle can occur. The NOHOLD bit of the primary-bit-control register overwrites the $\overline{\text{HOLD}}$ signal.

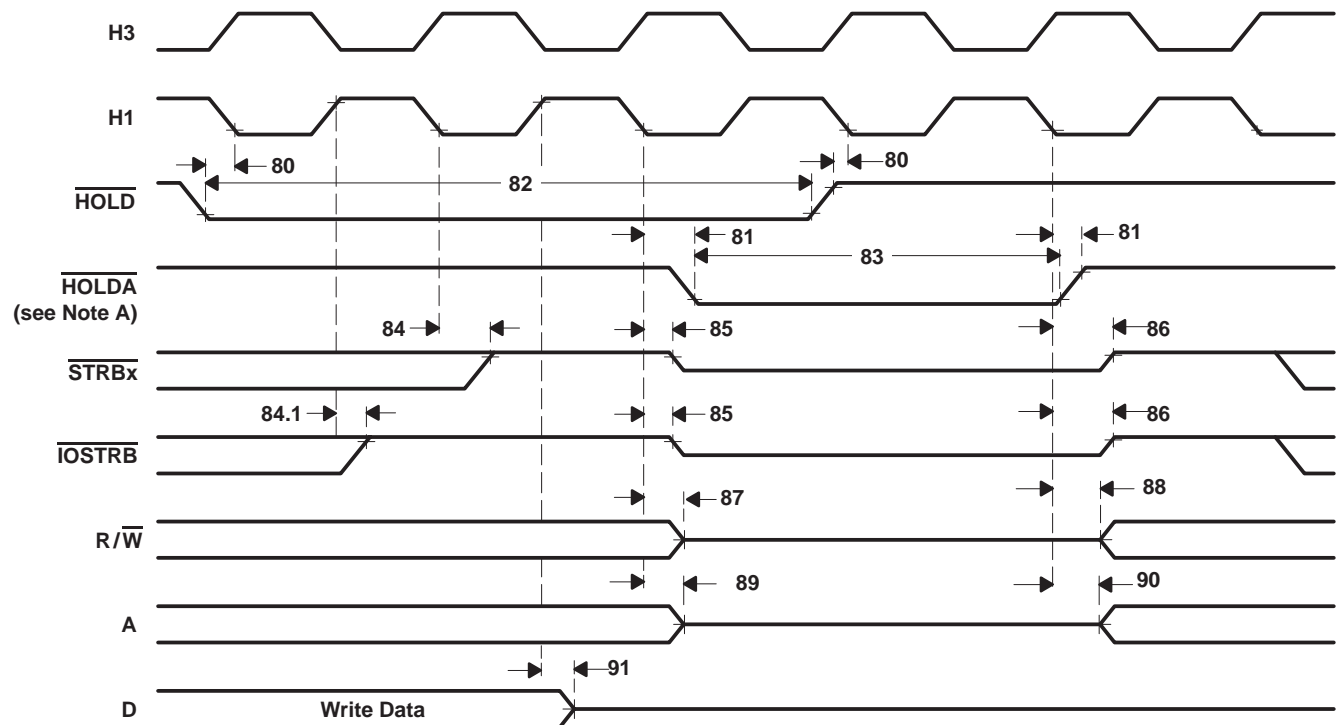

NOTE A: $\overline{\text{HOLDA}}$ goes low in response to $\overline{\text{HOLD}}$ going low and continues to remain low until one H1 cycle after $\overline{\text{HOLD}}$ goes back high.

Figure 31. $\overline{\text{HOLD}}/\overline{\text{HOLDA}}$ Timing

SM320C32-EP DIGITAL SIGNAL PROCESSOR

SGUS038 – AUGUST 2002

timing of peripheral pin configured as general-purpose I/O (see Figure 32)

NO.		320C32-50		320C32-60		UNIT
		MIN	MAX	MIN	MAX	
92	$t_{su}(GPIOH1L)$ Setup time, general-purpose input before H1 low	9		8		ns
93	$t_h(GPIOH1L)$ Hold time, general-purpose input after H1 low	0		0		ns
94	$t_d(GPIOH1H)$ Delay time, general-purpose output after H1 high		10		8	ns

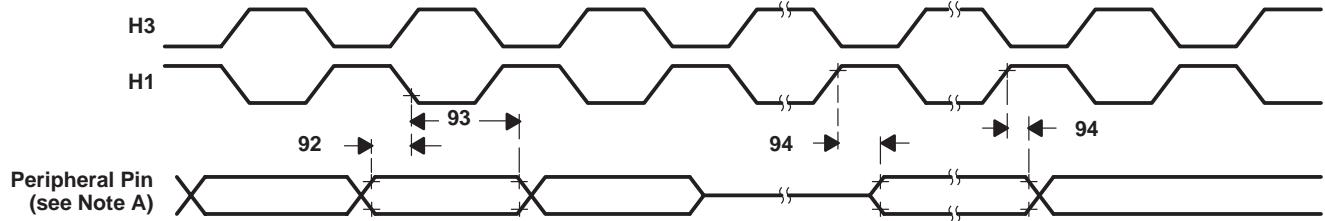

NOTE A: Peripheral pins include CLKX0, CLKR0, DX0, DR0, FSX0, FSR0, and TCLKx. The modes of these pins are defined by the contents of internal control registers associated with each peripheral.

Figure 32. Peripheral-Pin General-Purpose I/O Timing

timing of peripheral pin changing from general-purpose output to input mode (see Figure 33)

NO.		320C32-50		320C32-60		UNIT
		MIN	MAX	MIN	MAX	
95	$t_h(H1H)$ Hold time, after H1 high		12*		11*	ns
96	$t_{su}(GPIOH1L)$ Setup time, peripheral pin before H1 low	9		8		ns
97	$t_h(GPIOH1L)$ Hold time, peripheral pin after H1 low	0		0		ns

* This parameter is not production tested.

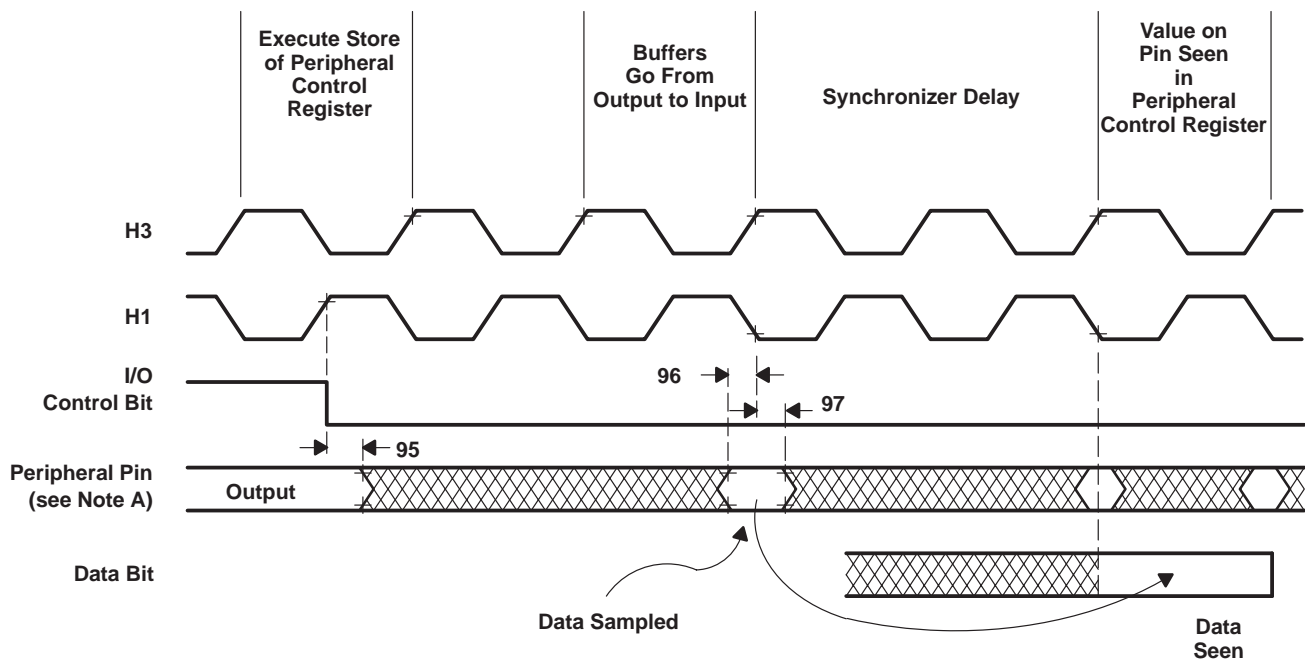

NOTE A: Peripheral pins include CLKX0, CLKR0, DX0, DR0, FSX0, FSR0, and TCLKx. The modes of these pins are defined by the contents of internal control registers associated with each peripheral.

Figure 33. Timing of Peripheral Pin Changing From General-Purpose Output to Input Mode

timing of peripheral pin changing from general-purpose input to output mode (see Figure 34)

NO.		320C32-50		320C32-60		UNIT
		MIN	MAX	MIN	MAX	
98	$t_d(\text{GPIOH1H})$ Delay time, H1 high to peripheral pin switching from input to output		10		8	ns

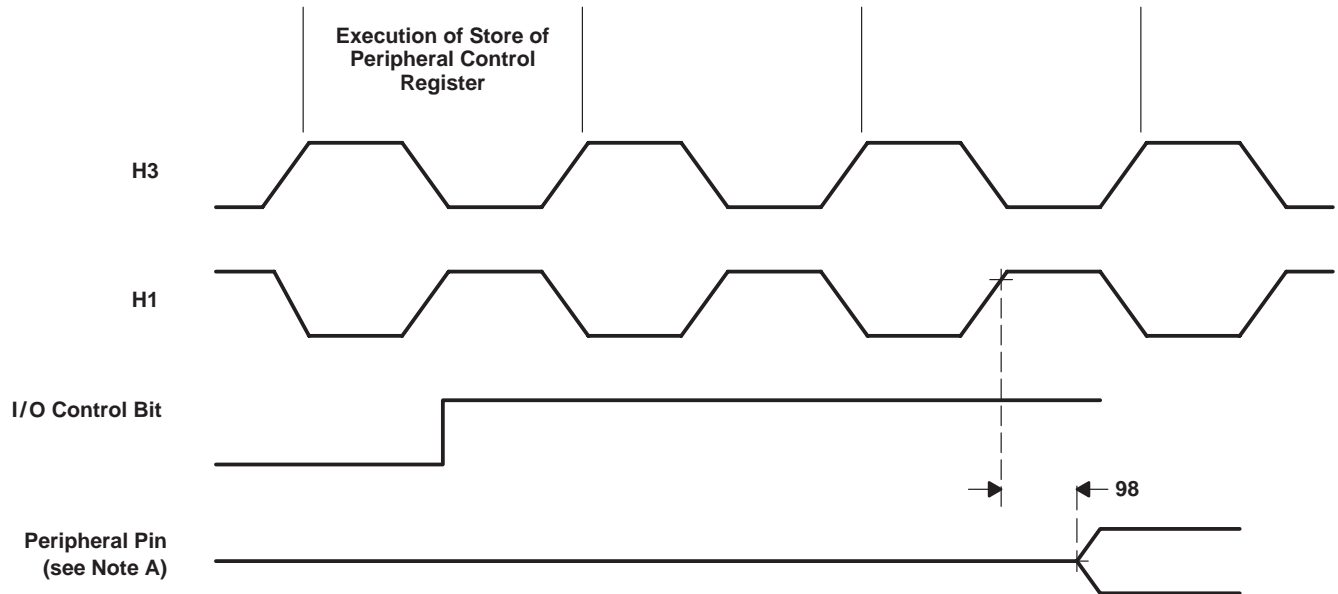

NOTE A: Peripheral pins include CLKX0, CLKR0, DX0, DR0, FSX0, FSR0, and TCLKx. The modes of these pins are defined by the contents of internal control registers associated with each peripheral.

Figure 34. Timing of Peripheral Pin Changing From General-Purpose Input-to-Output Mode

SM320C32-EP DIGITAL SIGNAL PROCESSOR

SGUS038 – AUGUST 2002

timing for timer pin [$P = t_c(H)$] (see Figure 35)

NO.			320C32-50		320C32-60		UNIT
			MIN	MAX	MIN	MAX	
99	$t_{su}(TCLKH1L)$	Setup time, TCLK external before H1 low	8		6		ns
100	$t_h(TCLKH1L)$	Hold time, TCLK external after H1 low	0		0		ns
101	$t_d(TCLKH1H)$	Delay time, H1 high to TCLK internal valid		9		8	ns
102	$t_c(TCLK)$	TCLK external	2.6P*		2.6P*		ns
		TCLK internal	2P	$(2^{32})P^*$	2P	$(2^{32})P^*$	
103	$t_w(TCLK)$	TCLK external	P + 10*		P + 10*		ns
		TCLK internal	$[t_c(TCLK)/2]-5$	$[t_c(TCLK)/2]+5$	$[t_c(TCLK)/2]-5$	$[t_c(TCLK)/2]+5$	

* This parameter is not production tested.

NOTE: Timing parameters 99 and 100 are applicable for a synchronous input clock. Timing parameters 102 and 103 are applicable for an asynchronous input clock.

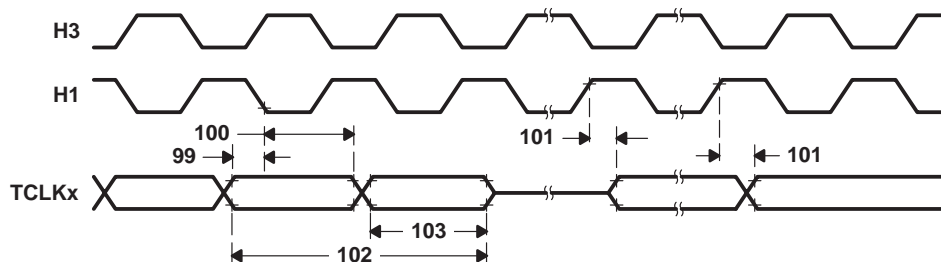
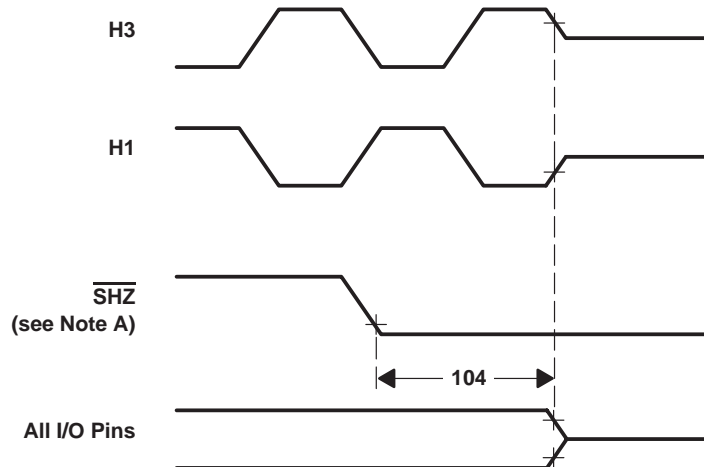

Figure 35. Timing for Timer Pin

timing for $\overline{\text{SHZ}}$ pin [$Q = t_c(C1)$] (see Figure 36)

NO.		320C32-50		320C32-60		UNIT
		MIN	MAX	MIN	MAX	
104	$t_{\text{dis}}(\overline{\text{SHZ}})$ Disable time, $\overline{\text{SHZ}}$ low to all O, I/O pins in the high-impedance state	0*	2Q*	0*	2Q*	ns

* This parameter is not production tested.



NOTE A: Enabling $\overline{\text{SHZ}}$ destroys C32 register and memory contents. Assert $\overline{\text{SHZ}} = 1$ and reset the C32 to restore it to a known condition.

Figure 36. $\overline{\text{SHZ}}$ Pin Timing

Table 1. Thermal Resistance Characteristics for PCM package

PARAMETER		MIN	MAX	UNIT
$R_{\theta JA}$	Junction-to-free-air		39	$^{\circ}\text{C}/\text{W}$
$R_{\theta JC}$	Junction-to-case		10.0	$^{\circ}\text{C}/\text{W}$

PACKAGING INFORMATION

Orderable Device	Status (1)	Package Type	Package Drawing	Pins	Package Qty	Eco Plan (2)	Lead/Ball Finish (6)	MSL Peak Temp (3)	Op Temp (°C)	Device Marking (4/5)	Samples
SM320C32PCMM50EP	NRND	QFP	PCM	144	24	TBD	Call TI	Call TI	-55 to 125	SM320C32PCMM50 EP	
SM320C32PCMM60EP	NRND	QFP	PCM	144	24	TBD	Call TI	Call TI	-55 to 125	SM320C32PCMM60 EP	
V62/03616-01XE	NRND	QFP	PCM	144	24	TBD	Call TI	Call TI	-55 to 125	SM320C32PCMM50 EP	
V62/03616-02XE	NRND	QFP	PCM	144	24	TBD	Call TI	Call TI	-55 to 125	SM320C32PCMM60 EP	

(1) The marketing status values are defined as follows:

ACTIVE: Product device recommended for new designs.

LIFEBUY: TI has announced that the device will be discontinued, and a lifetime-buy period is in effect.

NRND: Not recommended for new designs. Device is in production to support existing customers, but TI does not recommend using this part in a new design.

PREVIEW: Device has been announced but is not in production. Samples may or may not be available.

OBSELETE: TI has discontinued the production of the device.

(2) Eco Plan - The planned eco-friendly classification: Pb-Free (RoHS), Pb-Free (RoHS Exempt), or Green (RoHS & no Sb/Br) - please check <http://www.ti.com/productcontent> for the latest availability information and additional product content details.

TBD: The Pb-Free/Green conversion plan has not been defined.

Pb-Free (RoHS): TI's terms "Lead-Free" or "Pb-Free" mean semiconductor products that are compatible with the current RoHS requirements for all 6 substances, including the requirement that lead not exceed 0.1% by weight in homogeneous materials. Where designed to be soldered at high temperatures, TI Pb-Free products are suitable for use in specified lead-free processes.

Pb-Free (RoHS Exempt): This component has a RoHS exemption for either 1) lead-based flip-chip solder bumps used between the die and package, or 2) lead-based die adhesive used between the die and leadframe. The component is otherwise considered Pb-Free (RoHS compatible) as defined above.

Green (RoHS & no Sb/Br): TI defines "Green" to mean Pb-Free (RoHS compatible), and free of Bromine (Br) and Antimony (Sb) based flame retardants (Br or Sb do not exceed 0.1% by weight in homogeneous material)

(3) MSL, Peak Temp. - The Moisture Sensitivity Level rating according to the JEDEC industry standard classifications, and peak solder temperature.

(4) There may be additional marking, which relates to the logo, the lot trace code information, or the environmental category on the device.

(5) Multiple Device Markings will be inside parentheses. Only one Device Marking contained in parentheses and separated by a "~" will appear on a device. If a line is indented then it is a continuation of the previous line and the two combined represent the entire Device Marking for that device.

(6) Lead/Ball Finish - Orderable Devices may have multiple material finish options. Finish options are separated by a vertical ruled line. Lead/Ball Finish values may wrap to two lines if the finish value exceeds the maximum column width.

Important Information and Disclaimer: The information provided on this page represents TI's knowledge and belief as of the date that it is provided. TI bases its knowledge and belief on information provided by third parties, and makes no representation or warranty as to the accuracy of such information. Efforts are underway to better integrate information from third parties. TI has taken and continues to take reasonable steps to provide representative and accurate information but may not have conducted destructive testing or chemical analysis on incoming materials and chemicals. TI and TI suppliers consider certain information to be proprietary, and thus CAS numbers and other limited information may not be available for release.

In no event shall TI's liability arising out of such information exceed the total purchase price of the TI part(s) at issue in this document sold by TI to Customer on an annual basis.

PCM (S-PQFP-G***)

PLASTIC QUAD FLATPACK

144 PINS SHOWN

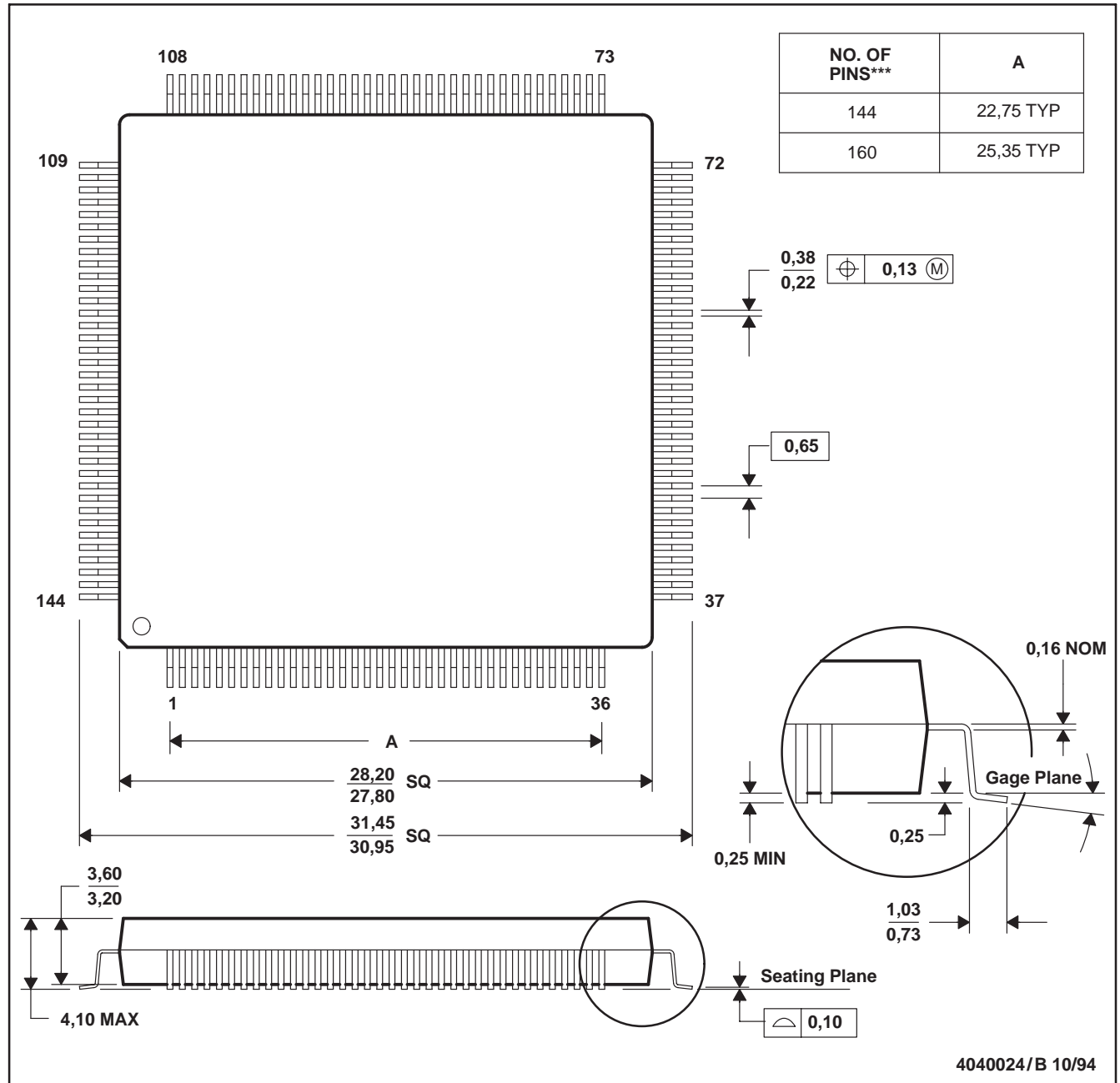

- NOTES: A. All linear dimensions are in millimeters.
 B. This drawing is subject to change without notice.
 C. Falls within JEDEC MS-022
 D. The 144 PCM is identical to the 160 PCM except that four leads per corner are removed.

IMPORTANT NOTICE

Texas Instruments Incorporated and its subsidiaries (TI) reserve the right to make corrections, enhancements, improvements and other changes to its semiconductor products and services per JESD46, latest issue, and to discontinue any product or service per JESD48, latest issue. Buyers should obtain the latest relevant information before placing orders and should verify that such information is current and complete. All semiconductor products (also referred to herein as "components") are sold subject to TI's terms and conditions of sale supplied at the time of order acknowledgment.

TI warrants performance of its components to the specifications applicable at the time of sale, in accordance with the warranty in TI's terms and conditions of sale of semiconductor products. Testing and other quality control techniques are used to the extent TI deems necessary to support this warranty. Except where mandated by applicable law, testing of all parameters of each component is not necessarily performed.

TI assumes no liability for applications assistance or the design of Buyers' products. Buyers are responsible for their products and applications using TI components. To minimize the risks associated with Buyers' products and applications, Buyers should provide adequate design and operating safeguards.

TI does not warrant or represent that any license, either express or implied, is granted under any patent right, copyright, mask work right, or other intellectual property right relating to any combination, machine, or process in which TI components or services are used. Information published by TI regarding third-party products or services does not constitute a license to use such products or services or a warranty or endorsement thereof. Use of such information may require a license from a third party under the patents or other intellectual property of the third party, or a license from TI under the patents or other intellectual property of TI.

Reproduction of significant portions of TI information in TI data books or data sheets is permissible only if reproduction is without alteration and is accompanied by all associated warranties, conditions, limitations, and notices. TI is not responsible or liable for such altered documentation. Information of third parties may be subject to additional restrictions.

Resale of TI components or services with statements different from or beyond the parameters stated by TI for that component or service voids all express and any implied warranties for the associated TI component or service and is an unfair and deceptive business practice. TI is not responsible or liable for any such statements.

Buyer acknowledges and agrees that it is solely responsible for compliance with all legal, regulatory and safety-related requirements concerning its products, and any use of TI components in its applications, notwithstanding any applications-related information or support that may be provided by TI. Buyer represents and agrees that it has all the necessary expertise to create and implement safeguards which anticipate dangerous consequences of failures, monitor failures and their consequences, lessen the likelihood of failures that might cause harm and take appropriate remedial actions. Buyer will fully indemnify TI and its representatives against any damages arising out of the use of any TI components in safety-critical applications.

In some cases, TI components may be promoted specifically to facilitate safety-related applications. With such components, TI's goal is to help enable customers to design and create their own end-product solutions that meet applicable functional safety standards and requirements. Nonetheless, such components are subject to these terms.

No TI components are authorized for use in FDA Class III (or similar life-critical medical equipment) unless authorized officers of the parties have executed a special agreement specifically governing such use.

Only those TI components which TI has specifically designated as military grade or "enhanced plastic" are designed and intended for use in military/aerospace applications or environments. Buyer acknowledges and agrees that any military or aerospace use of TI components which have **not** been so designated is solely at the Buyer's risk, and that Buyer is solely responsible for compliance with all legal and regulatory requirements in connection with such use.

TI has specifically designated certain components as meeting ISO/TS16949 requirements, mainly for automotive use. In any case of use of non-designated products, TI will not be responsible for any failure to meet ISO/TS16949.

Products

Audio	www.ti.com/audio
Amplifiers	amplifier.ti.com
Data Converters	dataconverter.ti.com
DLP® Products	www.dlp.com
DSP	dsp.ti.com
Clocks and Timers	www.ti.com/clocks
Interface	interface.ti.com
Logic	logic.ti.com
Power Mgmt	power.ti.com
Microcontrollers	microcontroller.ti.com
RFID	www.ti-rfid.com
OMAP Applications Processors	www.ti.com/omap
Wireless Connectivity	www.ti.com/wirelessconnectivity

Applications

Automotive and Transportation	www.ti.com/automotive
Communications and Telecom	www.ti.com/communications
Computers and Peripherals	www.ti.com/computers
Consumer Electronics	www.ti.com/consumer-apps
Energy and Lighting	www.ti.com/energy
Industrial	www.ti.com/industrial
Medical	www.ti.com/medical
Security	www.ti.com/security
Space, Avionics and Defense	www.ti.com/space-avionics-defense
Video and Imaging	www.ti.com/video

TI E2E Community

e2e.ti.com