

2.95-V to 17-V Input, 10-A Synchronous Buck, Integrated Power Solution

Check for Samples: [TPS84A20](#)

FEATURES

- Complete Integrated Power Solution Allows Small Footprint, Low-Profile Design
- 10mm x 10mm x 4.3mm package
- Efficiencies Up To 95%
- Eco-mode™ / Light Load Efficiency (LLE)
- Wide-Output Voltage Adjust
0.6 V to 5.5 V, with 1% Reference Accuracy
- Supports Parallel Operation for Higher Current
- Optional Split Power Rail allows input voltage down to 2.95 V
- Adjustable Switching Frequency (200 kHz to 1.2 MHz)
- Synchronizes to an External Clock
- Provides 180° out-of-phase clock signal
- Adjustable Slow-Start
- Output Voltage Sequencing / Tracking
- Power Good Output
- Programmable Undervoltage Lockout (UVLO)
- Over-Current & Over-Temperature Protection
- Pre-bias Output Start-up
- Operating Temperature Range: -40°C to 85°C
- Enhanced Thermal Performance: 13.3°C/W
- Meets EN55022 Class B Emissions

APPLICATIONS

- Broadband & Communications Infrastructure
- Automated Test and Medical Equipment
- Compact PCI / PCI Express / PXI Express
- DSP and FPGA Point-of-Load Applications

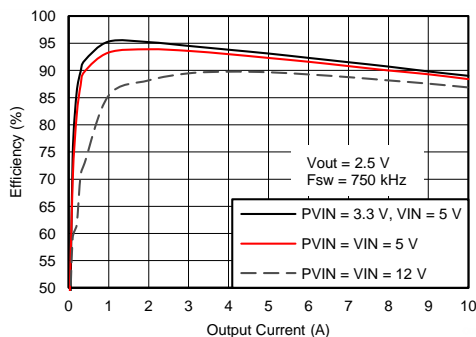

DESCRIPTION

The TPS84A20 is an easy-to-use integrated power solution that combines a 10-A DC/DC converter with power MOSFETs, an inductor, and passives into a low profile, QFN package. This total power solution allows as few as three external components and eliminates the loop compensation and magnetics part selection process.

The 10x10x4.3 mm QFN package is easy to solder onto a printed circuit board and allows a compact point-of-load design. Achieves greater than 95% efficiency and excellent power dissipation capability with a thermal impedance of 13.3°C/W. The TPS84A20 offers the flexibility and the feature-set of a discrete point-of-load design and is ideal for powering a wide range of ICs and systems. Advanced packaging technology affords a robust and reliable power solution compatible with standard QFN mounting and testing techniques.

SIMPLIFIED APPLICATION

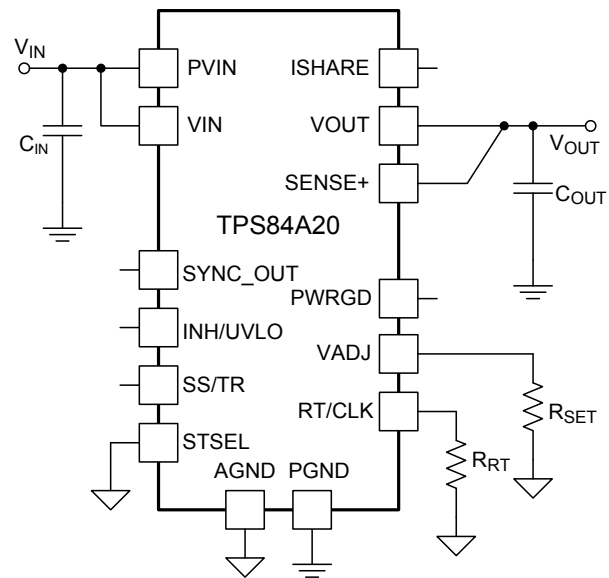

Please be aware that an important notice concerning availability, standard warranty, and use in critical applications of Texas Instruments semiconductor products and disclaimers thereto appears at the end of this data sheet.

Eco-mode is a trademark of Texas Instruments.



This integrated circuit can be damaged by ESD. Texas Instruments recommends that all integrated circuits be handled with appropriate precautions. Failure to observe proper handling and installation procedures can cause damage.

ESD damage can range from subtle performance degradation to complete device failure. Precision integrated circuits may be more susceptible to damage because very small parametric changes could cause the device not to meet its published specifications.

ABSOLUTE MAXIMUM RATINGS⁽¹⁾

over operating temperature range (unless otherwise noted)		MIN	MAX	UNIT
Input Voltage	VIN, PVIN	-0.3	20	V
	INH/UVLO, PWRGD, RT/CLK, SENSE+	-0.3	6	V
	ILIM, VADJ, SS/TR, STSEL, SYNC_OUT, ISHARE, OCP_SEL	-0.3	3	V
Output Voltage	PH	-1.0	20	V
	PH 10ns Transient	-3.0	20	V
	VOUT	-0.3	6	V
Source Current	RT/CLK, INH/UVLO		±100	µA
	PH		current limit	A
Sink Current	PH		current limit	A
	PVIN		current limit	A
	PWRGD	-0.1	2	mA
Operating Junction Temperature		-40	125 ⁽²⁾	°C
Storage Temperature		-65	150	°C
Mechanical Shock	Mil-STD-883D, Method 2002.3, 1 msec, 1/2 sine, mounted		1500	G
Mechanical Vibration	Mil-STD-883D, Method 2007.2, 20-2000Hz		20	

- (1) Stresses beyond those listed under absolute maximum ratings may cause permanent damage to the device. These are stress ratings only, and functional operation of the device at these or any other conditions beyond those indicated under recommended operating conditions is not implied. Exposure to absolute-maximum-rated conditions for extended periods may affect device reliability.
- (2) See the temperature derating curves in the Typical Characteristics section for thermal information.

RECOMMENDED OPERATING CONDITIONS

over operating free-air temperature range (unless otherwise noted)		MIN	NOM	MAX	UNIT
PVIN	Input Switching Voltage	2.95		17	V
VIN	Input Bias Voltage	4.5		17	V
VOUT	Output Voltage	0.6		5.5	V
f _{SW}	Switching Frequency	200		1200	kHz

PACKAGE SPECIFICATIONS

TPS84A20		UNIT
Weight		1.45 grams
Flammability	Meets UL 94 V-O	
MTBF Calculated reliability	Per Bellcore TR-332, 50% stress, T _A = 40°C, ground benign	37.4 Mhrs

ORDERING INFORMATION

For the most current package and ordering information, see the Package Option Addendum at the end of this datasheet, or see the TI website at www.ti.com.

ELECTRICAL CHARACTERISTICS

Over -40°C to 85°C free-air temperature, $P_{VIN} = V_{IN} = 12\text{ V}$, $V_{OUT} = 1.8\text{ V}$, $I_{OUT} = 10\text{ A}$,
 $C_{IN} = 0.1\text{ }\mu\text{F} + 2 \times 22\text{ }\mu\text{F}$ ceramic + $100\text{ }\mu\text{F}$ bulk, $C_{OUT} = 4 \times 47\text{ }\mu\text{F}$ ceramic (unless otherwise noted)

PARAMETER	TEST CONDITIONS	MIN	TYP	MAX	UNIT	
I_{OUT}	Output current	$T_A = 85^{\circ}\text{C}$, natural convection			0 ⁽¹⁾	A
V_{IN}	Input bias voltage range	Over output current range			4.5	V
P_{VIN}	Input switching voltage range	Over output current range			2.95 ⁽²⁾	V
UVLO	V_{IN} Undervoltage lockout	V_{IN} Increasing			4.0	V
		V_{IN} Decreasing			4.5	
$V_{OUT(adj)}$	Output voltage adjust range	Over output current range			0.6	V
V_{OUT}	Set-point voltage tolerance	$T_A = 25^{\circ}\text{C}$, $I_{OUT} = 0\text{ A}$			$\pm 1\%$ ⁽⁴⁾	
	Temperature variation	$-40^{\circ}\text{C} \leq T_A \leq +85^{\circ}\text{C}$, $I_{OUT} = 0\text{ A}$			$\pm 0.2\%$	
	Line regulation	Over input voltage range			$\pm 0.1\%$	
	Load regulation	Over output current range			$\pm 0.2\%$	
	Total output voltage variation	Includes set-point, line, load, and temperature variation			$\pm 1.5\%$ ⁽⁴⁾	
η	Efficiency	$P_{VIN} = V_{IN} = 12\text{ V}$ $I_O = 5\text{ A}$	$V_{OUT} = 5.0\text{ V}$, $f_{SW} = 1\text{ MHz}$		93%	
			$V_{OUT} = 3.3\text{ V}$, $f_{SW} = 750\text{ kHz}$		92%	
			$V_{OUT} = 2.5\text{ V}$, $f_{SW} = 750\text{ kHz}$		90%	
			$V_{OUT} = 1.8\text{ V}$, $f_{SW} = 500\text{ kHz}$		89%	
			$V_{OUT} = 1.2\text{ V}$, $f_{SW} = 300\text{ kHz}$		86%	
			$V_{OUT} = 0.9\text{ V}$, $f_{SW} = 250\text{ kHz}$		84%	
		$P_{VIN} = V_{IN} = 5\text{ V}$ $I_O = 5\text{ A}$	$V_{OUT} = 3.3\text{ V}$, $f_{SW} = 750\text{ kHz}$		94%	
			$V_{OUT} = 2.5\text{ V}$, $f_{SW} = 750\text{ kHz}$		93%	
			$V_{OUT} = 1.8\text{ V}$, $f_{SW} = 500\text{ kHz}$		92%	
			$V_{OUT} = 1.2\text{ V}$, $f_{SW} = 300\text{ kHz}$		89%	
			$V_{OUT} = 0.9\text{ V}$, $f_{SW} = 250\text{ kHz}$		87%	
			$V_{OUT} = 0.6\text{ V}$, $f_{SW} = 200\text{ kHz}$		83%	
	Output voltage ripple	20 MHz bandwidth		14	mV _{P-P}	
I_{LIM}	Current limit threshold	ILIM pin open		15	A	
		ILIM pin to AGND		12	A	
Transient response	1.0 A/ μs load step from 25 to 75% $I_{OUT(max)}$	Recovery time		100	μs	
		VOUT over/undershoot		80	mV	
V_{INH}	Inhibit threshold voltage	Inhibit High Voltage		1.3	open ⁽⁵⁾	
		Inhibit Low Voltage		-0.3	1.1	
I_{INH}	INH Input current	$V_{INH} < 1.1\text{ V}$		-1.15	μA	
	INH Hysteresis current	$V_{INH} > 1.3\text{ V}$		-3.3	μA	
$I_{I(stby)}$	Input standby current	INH pin to AGND		2	10	
Power Good	PWRGD Thresholds	V_{OUT} rising	Good	95%		
			Fault	108%		
		V_{OUT} falling	Fault	91%		
			Good	104%		
PWRGD Low Voltage	$I(PWRGD) = 0.5\text{ mA}$		0.3	V		
f_{SW}	Switching frequency	$R_{RT} = 169\text{ k}\Omega$		400	500	
f_{CLK}	Synchronization frequency			200	1200	
V_{CLK-H}	CLK High-Level	CLK Control		2.0	5.5	
V_{CLK-L}	CLK Low-Level				0.5	
D_{CLK}	CLK Duty Cycle			20	50	80

- (1) See [Light Load Efficiency \(LLE\)](#) section for more information for output voltages $< 1.5\text{ V}$.
- (2) The minimum P_{VIN} is 2.95 V or $(V_{OUT} + 0.7\text{ V})$, whichever is greater. See [Table 7](#) for more details.
- (3) The maximum P_{VIN} voltage is 17 V or $(22 \times V_{OUT})$, whichever is less. See [Table 7](#) for more details.
- (4) The stated limit of the set-point voltage tolerance includes the tolerance of both the internal voltage reference and the internal adjustment resistor. The overall output voltage tolerance will be affected by the tolerance of the external R_{SET} resistor.
- (5) Value when no voltage divider is present at the INH/UVLO pin. This pin has an internal pull-up. If it is left open, the device operates when input power is applied. A small, low-leakage MOSFET is recommended for control. Do not tie this pin to VIN.

ELECTRICAL CHARACTERISTICS (continued)

Over -40°C to 85°C free-air temperature, $PV_{\text{IN}} = V_{\text{IN}} = 12\text{ V}$, $V_{\text{OUT}} = 1.8\text{ V}$, $I_{\text{OUT}} = 10\text{ A}$,
 $C_{\text{IN}} = 0.1\text{ }\mu\text{F} + 2 \times 22\text{ }\mu\text{F}$ ceramic + $100\text{ }\mu\text{F}$ bulk, $C_{\text{OUT}} = 4 \times 47\text{ }\mu\text{F}$ ceramic (unless otherwise noted)

PARAMETER	TEST CONDITIONS	MIN	TYP	MAX	UNIT
Thermal Shutdown	Thermal shutdown		175		$^{\circ}\text{C}$
	Thermal shutdown hysteresis		10		$^{\circ}\text{C}$
C_{IN} External input capacitance	Ceramic	44 ⁽⁶⁾			μF
	Non-ceramic		100 ⁽⁶⁾		
C_{OUT} External output capacitance	Ceramic	47 ⁽⁷⁾	200	1500	μF
	Non-ceramic		220 ⁽⁷⁾	5000	
	Equivalent series resistance (ESR)				35

- (6) A minimum of $44\text{ }\mu\text{F}$ of external ceramic capacitance is required across the input (V_{IN} and PV_{IN} connected) for proper operation. An additional $100\text{ }\mu\text{F}$ of bulk capacitance is recommended. It is also recommended to place a $0.1\text{ }\mu\text{F}$ ceramic capacitor directly across the PV_{IN} and PGND pins of the device. Locate the input capacitance close to the device. When operating with split V_{IN} and PV_{IN} rails, place $4.7\text{ }\mu\text{F}$ of ceramic capacitance directly at the V_{IN} pin. See [Table 4](#) for more details.
- (7) The amount of required output capacitance varies depending on the output voltage (see [Table 3](#)). The amount of required capacitance must include at least $1 \times 47\text{ }\mu\text{F}$ ceramic capacitor. Locate the capacitance close to the device. Adding additional capacitance close to the load improves the response of the regulator to load transients. See [Table 3](#) and [Table 4](#) more details.

THERMAL INFORMATION

THERMAL METRIC ⁽¹⁾		TPS84A20	UNIT
		RVQ42	
		42 PINS	
θ_{JA}	Junction-to-ambient thermal resistance ⁽²⁾	13.3	$^{\circ}\text{C}/\text{W}$
ψ_{JT}	Junction-to-top characterization parameter ⁽³⁾	1.6	
ψ_{JB}	Junction-to-board characterization parameter ⁽⁴⁾	5.3	

- (1) For more information about traditional and new thermal metrics, see the IC Package Thermal Metrics application report, [SPRA953](#).
- (2) The junction-to-ambient thermal resistance, θ_{JA} , applies to devices soldered directly to a $100\text{ mm} \times 100\text{ mm}$ double-sided PCB with 2 oz. copper and natural convection cooling. Additional airflow reduces θ_{JA} .
- (3) The junction-to-top characterization parameter, ψ_{JT} , estimates the junction temperature, T_{J} , of a device in a real system, using a procedure described in JESD51-2A (sections 6 and 7). $T_{\text{J}} = \psi_{\text{JT}} * P_{\text{dis}} + T_{\text{T}}$; where P_{dis} is the power dissipated in the device and T_{T} is the temperature of the top of the device.
- (4) The junction-to-board characterization parameter, ψ_{JB} , estimates the junction temperature, T_{J} , of a device in a real system, using a procedure described in JESD51-2A (sections 6 and 7). $T_{\text{J}} = \psi_{\text{JB}} * P_{\text{dis}} + T_{\text{B}}$; where P_{dis} is the power dissipated in the device and T_{B} is the temperature of the board 1mm from the device.

DEVICE INFORMATION
FUNCTIONAL BLOCK DIAGRAM

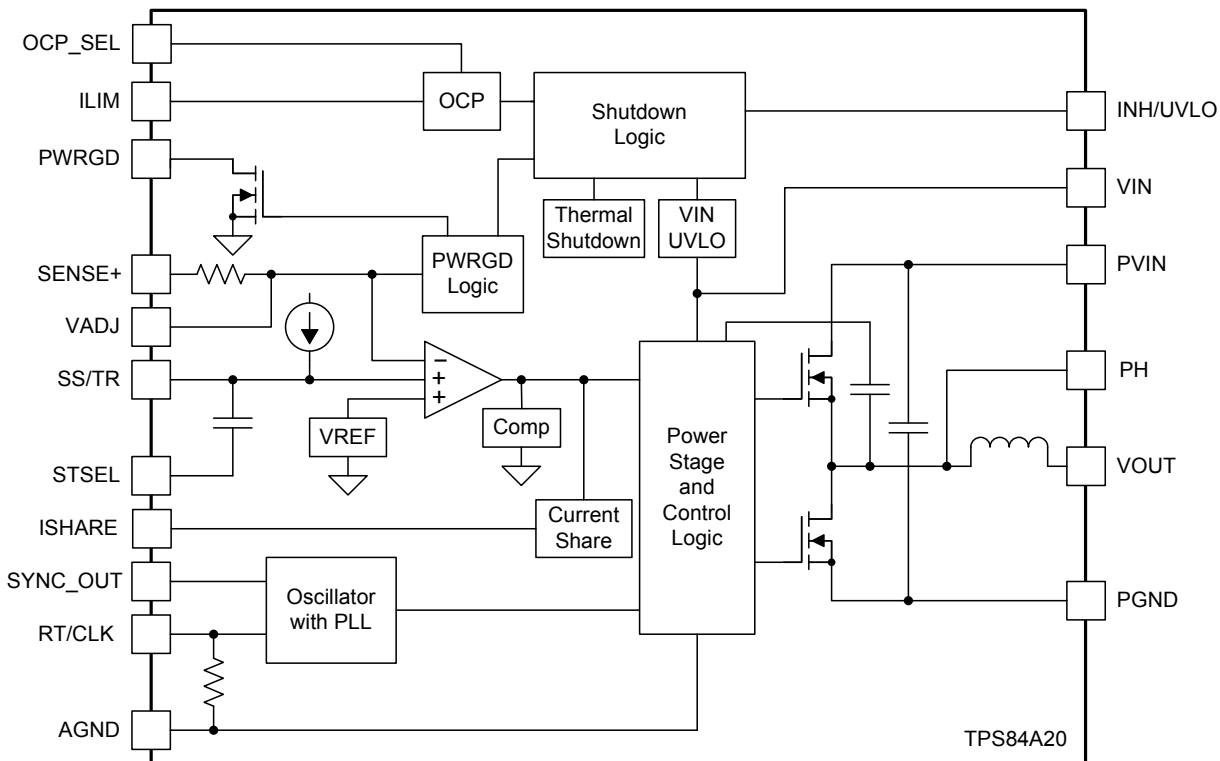

TPS84A20

PIN DESCRIPTIONS

TERMINAL		DESCRIPTION
NAME	NO.	
AGND	2	Zero volt reference for the analog control circuit. These pins are not connected together internal to the device and must be connected to one another using an AGND plane of the PCB. These pins are associated with the internal analog ground (AGND) of the device. See Layout Recommendations.
	23	
PGND	20	This is the return current path for the power stage of the device. Connect these pins to the load and to the bypass capacitors associated with PVIN and VOUT.
	21	
	31	
	32	
	33	
VIN	3	Input bias voltage pin. Supplies the control circuitry of the power converter. Connect this pin to the input bias supply. Connect bypass capacitors between this pin and PGND.
PVIN	1	Input switching voltage. Supplies voltage to the power switches of the converter. Connect these pins to the input supply. Connect bypass capacitors between these pins and PGND.
	11	
	12	
	39	
	40	
VOUT	34	Output voltage. These pins are connected to the internal output inductor. Connect these pins to the output load and connect external bypass capacitors between these pins and PGND.
	35	
	36	
	37	
	38	
	41	
PH	10	Phase switch node. These pins must be connected to one another using a small copper island under the device for thermal relief. Do not place any external component on these pins or tie them to a pin of another function.
	13	
	14	
	15	
	16	
	17	
	18	
	19	
DNC	5	Do Not Connect. Do not connect these pins to AGND, to another DNC pin, or to any other voltage. These pins are connected to internal circuitry. Each pin must be soldered to an isolated pad.
	9	
	24	
ISHARE	25	Current share pin. Connect this pin to other TPS84A20 device's ISHARE pin when paralleling multiple TPS84A20 devices. When unused, treat this pin as a Do Not Connect (DNC) and leave it isolated from all other signals or ground.
OCP_SEL	4	Over current protection select pin. Leave this pin open for hiccup mode operation. Connect this pin to AGND for cycle-by-cycle operation. See Overcurrent Protection for more details.
ILIM	6	Current limit pin. Leave this pin open for full current limit threshold. Connect this pin to AGND to reduce the current limit threshold by approximately 20%.
SYNC_OUT	7	Synchronization output pin. Provides a 180° out-of-phase clock signal.
PWRGD	8	Power Good flag pin. This open drain output asserts low if the output voltage is more than approximately ±6% out of regulation. A pull-up resistor is required.
RT/CLK	22	This pin is connected to an internal frequency setting resistor which sets the default switching frequency. An external resistor can be connected from this pin to AGND to increase the frequency. This pin can also be used to synchronize to an external clock.
VADJ	26	Connecting a resistor between this pin and AGND sets the output voltage.
SENSE+	27	Remote sense connection. This pin must be connected to VOUT at the load or at the device pins. Connect this pin to VOUT at the load for improved regulation.

PIN DESCRIPTIONS (continued)

TERMINAL		DESCRIPTION
NAME	NO.	
SS/TR	28	Slow-start and tracking pin. Connecting an external capacitor to this pin adjusts the output voltage rise time. A voltage applied to this pin allows for tracking and sequencing control.
STSEL	29	Slow-start or track feature select. Connect this pin to AGND to enable the internal SS capacitor. Leave this pin open to enable the TR feature.
INH/UVLO	30	Inhibit and UVLO adjust pin. Use an open drain or open collector logic device to ground this pin to control the INH function. A resistor divider between this pin, AGND, and PVIN/VIN sets the UVLO voltage.

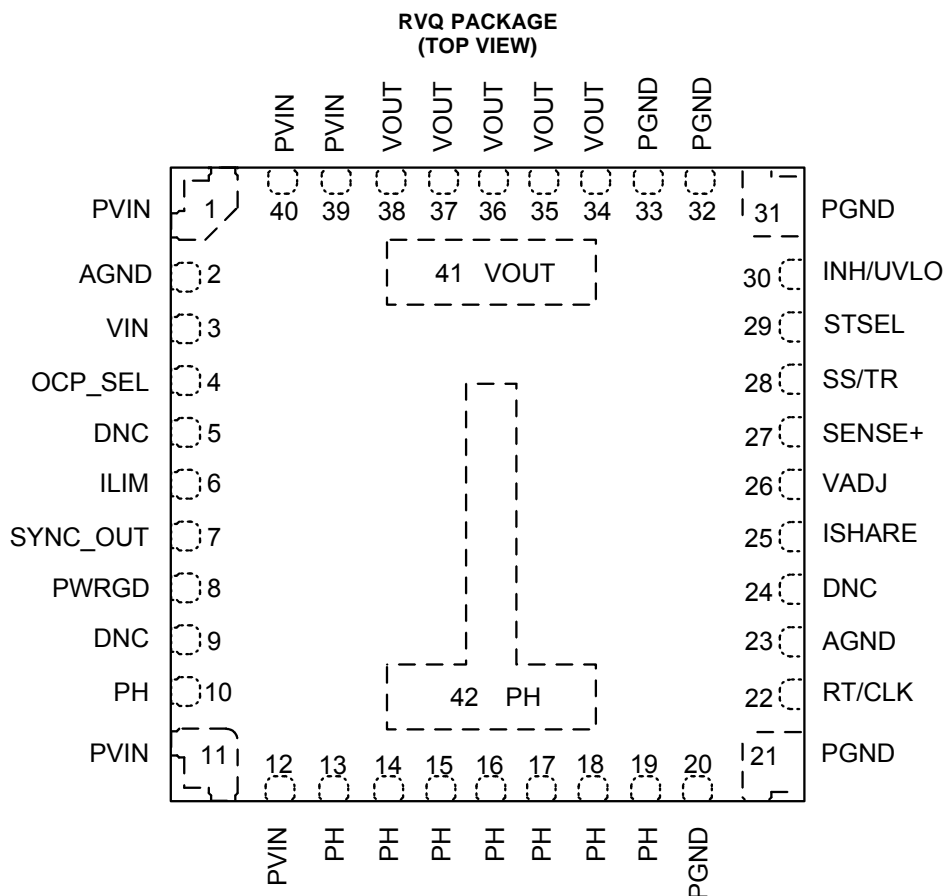

TYPICAL CHARACTERISTICS (P_{VIN} = V_{IN} = 12 V) (1) (2)

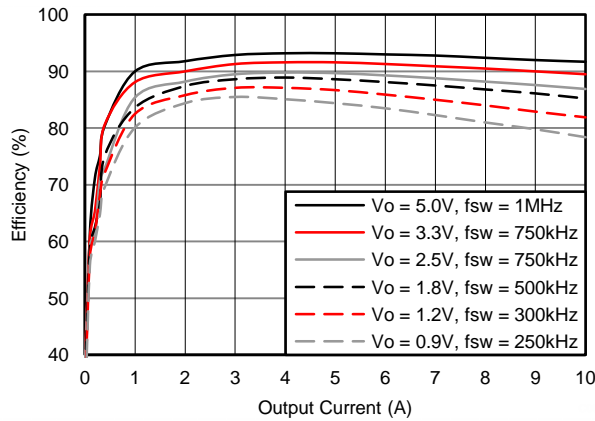

Figure 1. Efficiency vs. Output Current

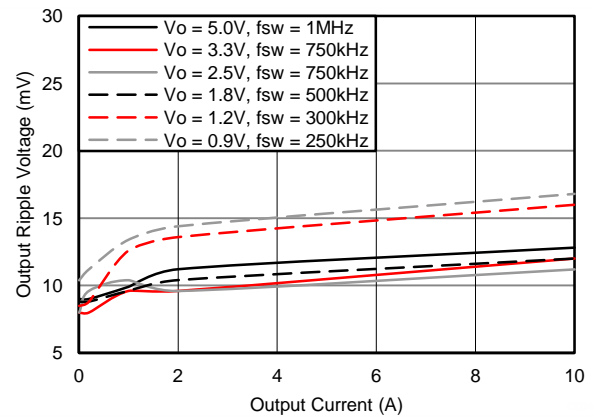

Figure 2. Voltage Ripple vs. Output Current

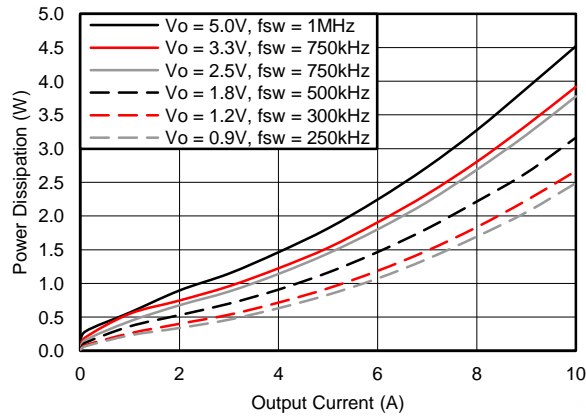

Figure 3. Power Dissipation vs. Output Current

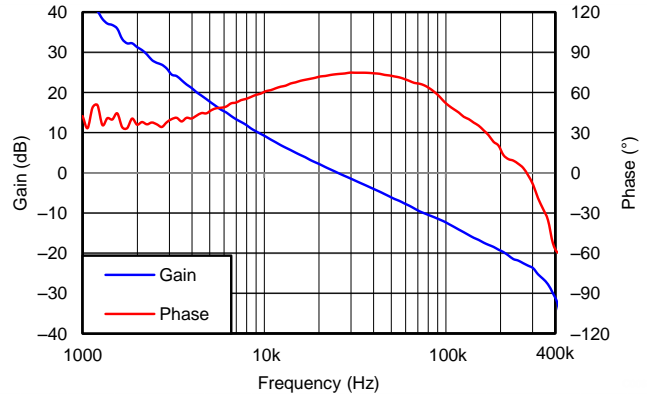

Figure 4. V_{OUT} = 1.8 V, I_{OUT} = 10 A, C_{OUT1} = 200 μF ceramic, f_{sw} = 500 kHz

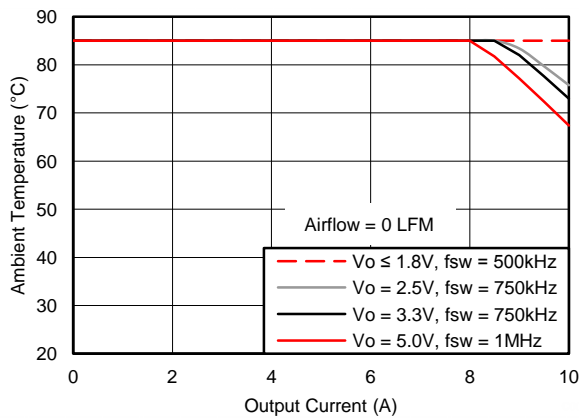

Figure 5. Safe Operating Area

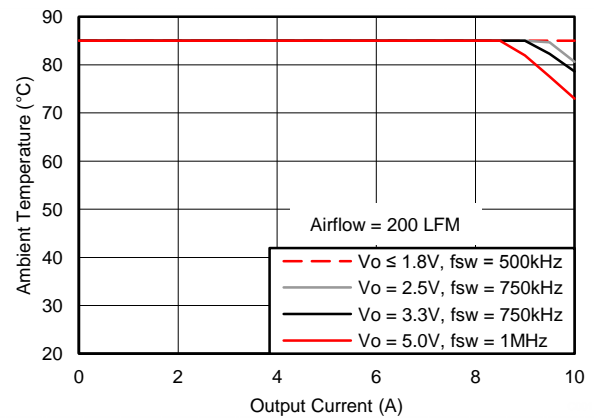

Figure 6. Safe Operating Area

- (1) The electrical characteristic data has been developed from actual products tested at 25°C. This data is considered typical for the converter. Applies to Figure 1, Figure 2, and Figure 3.
- (2) The temperature derating curves represent the conditions at which internal components are at or below the manufacturer's maximum operating temperatures. Derating limits apply to devices soldered directly to a 100 mm × 100 mm double-sided PCB with 2 oz. copper. Applies to Figure 5 and Figure 6.

TYPICAL CHARACTERISTICS (P_{VIN} = V_{IN} = 5 V) ⁽¹⁾ ⁽²⁾

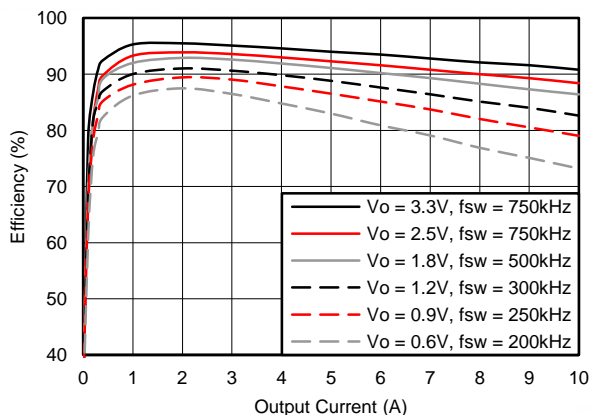

Figure 7. Efficiency vs. Output Current

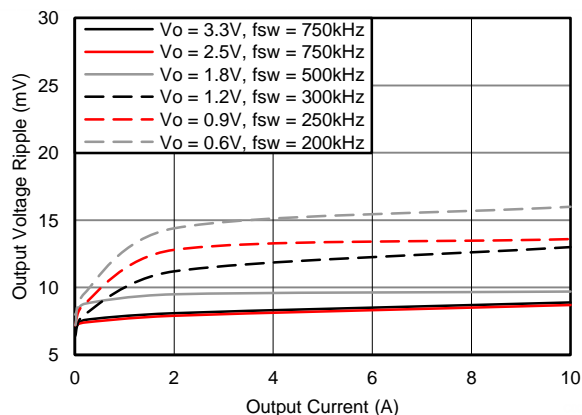

Figure 8. Voltage Ripple vs. Output Current

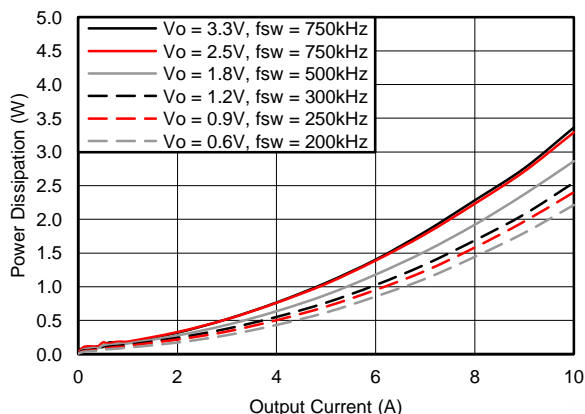

Figure 9. Power Dissipation vs. Output Current

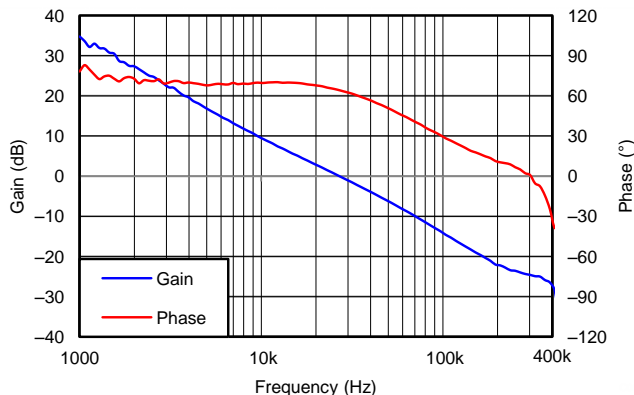

Figure 10. V_{OUT} = 1.8 V, I_{OUT} = 10 A, C_{OUT1} = 200 μF ceramic, f_{sw} = 500 kHz

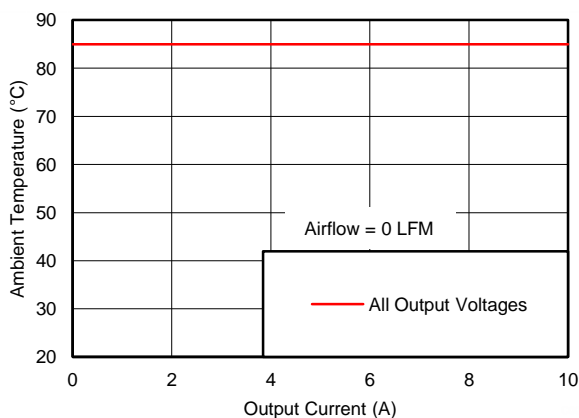

Figure 11. Safe Operating Area

- (1) The electrical characteristic data has been developed from actual products tested at 25°C. This data is considered typical for the converter. Applies to [Figure 7](#), [Figure 8](#), and [Figure 9](#).
- (2) The temperature derating curves represent the conditions at which internal components are at or below the manufacturer's maximum operating temperatures. Derating limits apply to devices soldered directly to a 100 mm × 100 mm double-sided PCB with 2 oz. copper. Applies to [Figure 11](#).

TYPICAL CHARACTERISTICS (P_{VIN} = 3.3 V, V_{IN} = 5 V) ⁽¹⁾ ⁽²⁾

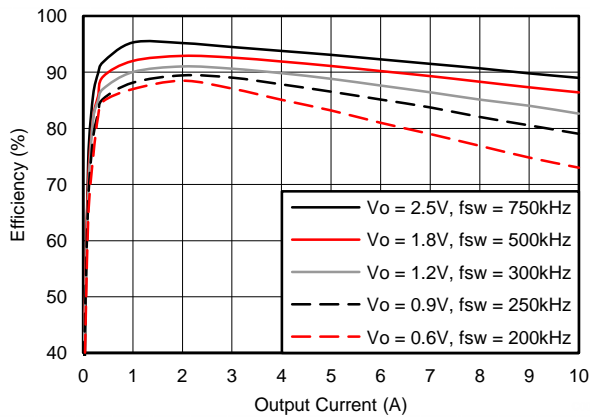

Figure 12. Efficiency vs. Output Current

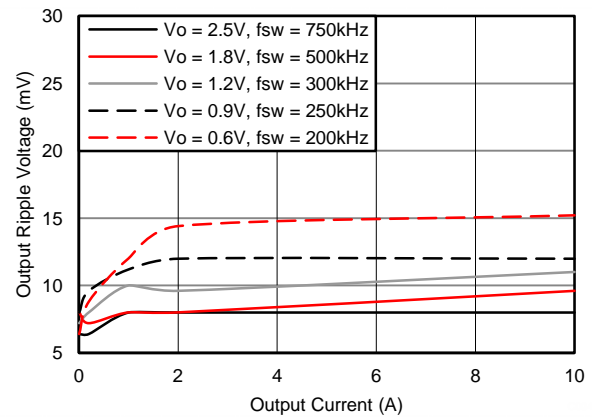

Figure 13. Voltage Ripple vs. Output Current

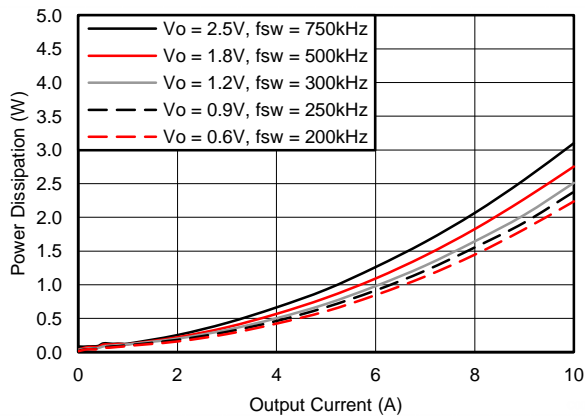

Figure 14. Power Dissipation vs. Output Current

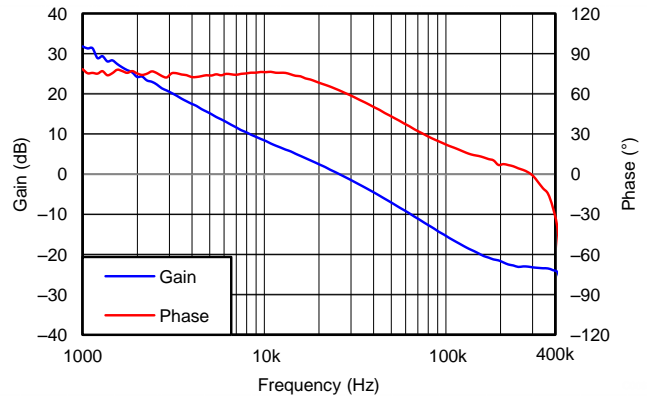

Figure 15. V_{OUT} = 1.8 V, I_{OUT} = 10 A, C_{OUT1} = 200 μF ceramic, f_{sw} = 500 kHz

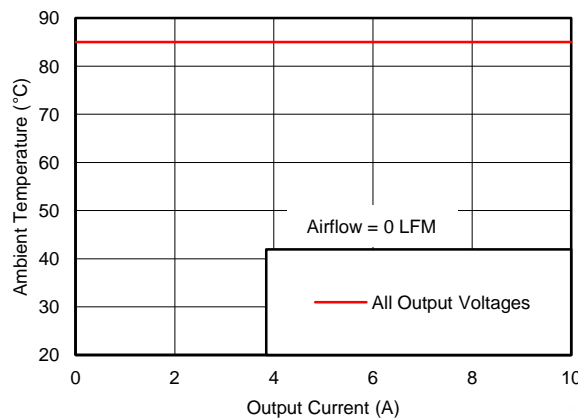

Figure 16. Safe Operating Area

- (1) The electrical characteristic data has been developed from actual products tested at 25°C. This data is considered typical for the converter. Applies to [Figure 12](#), [Figure 13](#), and [Figure 14](#).
- (2) The temperature derating curves represent the conditions at which internal components are at or below the manufacturer's maximum operating temperatures. Derating limits apply to devices soldered directly to a 100 mm × 100 mm double-sided PCB with 2 oz. copper. Applies to [Figure 16](#).

APPLICATION INFORMATION

ADJUSTING THE OUTPUT VOLTAGE

The V_{ADJ} control sets the output voltage of the TPS84A20. The output voltage adjustment range is from 0.6V to 5.5V. The adjustment method requires the addition of R_{SET}, which sets the output voltage, the connection of SENSE+ to V_{OUT}, and in some cases R_{RT} which sets the switching frequency. The R_{SET} resistor must be connected directly between the V_{ADJ} (pin 26) and AGND (pin 23). The SENSE+ pin (pin 27) must be connected to V_{OUT} either at the load for improved regulation or at V_{OUT} of the device. The R_{RT} resistor must be connected directly between the RT/CLK (pin 22) and AGND (pin 23). [Table 1](#) gives the standard external R_{SET} resistor for a number of common bus voltages, along with the recommended R_{RT} resistor for that output voltage.

Table 1. Standard R_{SET} Resistor Values for Common Output Voltages

RESISTORS	OUTPUT VOLTAGE V _{OUT} (V)						
	0.9	1.0	1.2	1.8	2.5	3.3	5.0
R _{SET} (kΩ)	2.87	2.15	1.43	0.715	0.453	0.316	0.196
R _{RT} (kΩ)	1000	1000	487	169	90.9	90.9	63.4

For other output voltages, the value of the required resistor can either be calculated using the following formula, or simply selected from the range of values given in [Table 2](#).

$$R_{SET} = \frac{1.43}{\left(\left(\frac{V_{OUT}}{0.6}\right) - 1\right)} \text{ (k}\Omega\text{)} \quad (1)$$

Table 2. Standard R_{SET} Resistor Values

V _{OUT} (V)	R _{SET} (kΩ)	R _{RT} (kΩ)	f _{sw} (kHz)	V _{OUT} (V)	R _{SET} (kΩ)	R _{RT} (kΩ)	f _{sw} (kHz)
0.6	open	OPEN	200	3.1	0.348	90.9	750
0.7	8.66	OPEN	200	3.2	0.332	90.9	750
0.8	4.32	OPEN	200	3.3	0.316	90.9	750
0.9	2.87	1000	250	3.4	0.309	90.9	750
1.0	2.15	1000	250	3.5	0.294	90.9	750
1.1	1.74	1000	250	3.6	0.287	90.9	750
1.2	1.43	487	300	3.7	0.280	90.9	750
1.3	1.24	487	300	3.8	0.267	90.9	750
1.4	1.07	487	300	3.9	0.261	90.9	750
1.5	0.953	487	300	4.0	0.255	90.9	750
1.6	0.866	487	300	4.1	0.243	63.4	1000
1.7	0.787	487	300	4.2	0.237	63.4	1000
1.8	0.715	169	500	4.3	0.232	63.4	1000
1.9	0.665	169	500	4.4	0.226	63.4	1000
2.0	0.619	169	500	4.5	0.221	63.4	1000
2.1	0.576	169	500	4.6	0.215	63.4	1000
2.2	0.536	169	500	4.7	0.210	63.4	1000
2.3	0.511	169	500	4.8	0.205	63.4	1000
2.4	0.475	169	500	4.9	0.200	63.4	1000
2.5	0.453	90.9	750	5.0	0.196	63.4	1000
2.6	0.432	90.9	750	5.1	0.191	63.4	1000
2.7	0.412	90.9	750	5.2	0.187	63.4	1000
2.8	0.392	90.9	750	5.3	0.182	63.4	1000
2.9	0.374	90.9	750	5.4	0.178	63.4	1000
3.0	0.357	90.9	750	5.5	0.174	63.4	1000

CAPACITOR RECOMMENDATIONS FOR THE TPS84A20 POWER SUPPLY

Capacitor Technologies

Electrolytic, Polymer-Electrolytic Capacitors

When using electrolytic capacitors, high-quality, computer-grade electrolytic capacitors are recommended. Polymer-electrolytic type capacitors are recommended for applications where the ambient operating temperature is less than 0°C. The Sanyo OS-CON capacitor series is suggested due to the lower ESR, higher rated surge, power dissipation, ripple current capability, and small package size. Aluminum electrolytic capacitors provide adequate decoupling over the frequency range of 2 kHz to 150 kHz, and are suitable when ambient temperatures are above 0°C.

Ceramic Capacitors

The performance of aluminum electrolytic capacitors is less effective than ceramic capacitors above 150 kHz. Multilayer ceramic capacitors have a low ESR and a resonant frequency higher than the bandwidth of the regulator. They can be used to reduce the reflected ripple current at the input as well as improve the transient response of the output.

Tantalum, Polymer-Tantalum Capacitors

Polymer-tantalum type capacitors are recommended for applications where the ambient operating temperature is less than 0°C. The Sanyo POSCAP series and Kemet T530 capacitor series are recommended rather than many other tantalum types due to their lower ESR, higher rated surge, power dissipation, ripple current capability, and small package size. Tantalum capacitors that have no stated ESR or surge current rating are not recommended for power applications.

Input Capacitor

The TPS84A20 requires a minimum input capacitance of 44 μF of ceramic type. An additional 100 μF of non-ceramic capacitance is recommended for applications with transient load requirements. The voltage rating of input capacitors must be greater than the maximum input voltage. At worst case, when operating at 50% duty cycle and maximum load, the combined ripple current rating of the input capacitors must be at least 5 Arms. [Table 4](#) includes a preferred list of capacitors by vendor. It is also recommended to place a 0.1 μF ceramic capacitor directly across the PVIN and PGND pins of the device. When operating with split VIN and PVIN rails, place 4.7 μF of ceramic capacitance directly at the VIN pin.

Output Capacitor

The required output capacitance is determined by the output voltage of the TPS84A20. See [Table 3](#) for the amount of required capacitance. The effects of temperature and capacitor voltage rating must be considered when selecting capacitors to meet the minimum required capacitance. The required output capacitance can be comprised of all ceramic capacitors, or a combination of ceramic and bulk capacitors. The required capacitance must include at least one 47 μF ceramic. When adding additional non-ceramic bulk capacitors, low-ESR devices like the ones recommended in [Table 4](#) are required. The required capacitance above the minimum is determined by actual transient deviation requirements. See [Table 5](#) for typical transient response values for several output voltage, input voltage and capacitance combinations. [Table 4](#) includes a preferred list of capacitors by vendor.

Table 3. Required Output Capacitance

V _{OUT} RANGE (V)		MINIMUM REQUIRED C _{OUT} (μF)
MIN	MAX	
0.6	< 0.8	500 μF ⁽¹⁾
0.8	< 1.2	300 μF ⁽¹⁾
1.2	< 3.0	200 μF ⁽¹⁾
3.0	< 4.0	100 μF ⁽¹⁾
4.0	5.5	47 μF ceramic

(1) Minimum required must include at least one 47 μF ceramic capacitor.

Table 4. Recommended Input/Output Capacitors⁽¹⁾

VENDOR	SERIES	PART NUMBER	CAPACITOR CHARACTERISTICS		
			WORKING VOLTAGE (V)	CAPACITANCE (µF)	ESR ⁽²⁾ (mΩ)
Murata	X5R	GRM32ER61E226K	25	22	2
TDK	X5R	C3225X5R0J107M	6.3	100	2
TDK	X5R	C3225X5R0J476K	6.3	47	2
Murata	X5R	GRM32ER60J107M	6.3	100	2
Murata	X5R	GRM32ER60J476M	6.3	47	2
Panasonic	EEH-ZA	EEH-ZA1E101XP	25	100	30
Sanyo	POSCAP	16TQC68M	16	68	50
Kemet	T520	T520V107M010ASE025	10	100	25
Sanyo	POSCAP	10TPE220ML	10	220	25
Sanyo	POSCAP	6TPE100MI	6.3	100	25
Sanyo	POSCAP	2R5TPE220M7	2.5	220	7
Kemet	T530	T530D227M006ATE006	6.3	220	6
Kemet	T530	T530D337M006ATE010	6.3	330	10
Sanyo	POSCAP	2TPF330M6	2.0	330	6
Sanyo	POSCAP	6TPE330MFL	6.3	330	15

(1) Capacitor Supplier Verification, RoHS, Lead-free and Material Details

Consult capacitor suppliers regarding availability, material composition, RoHS and lead-free status, and manufacturing process requirements for any capacitors identified in this table.

(2) Maximum ESR @ 100kHz, 25°C.
Transient Response
Table 5. Output Voltage Transient Response

C _{IN1} = 3x 47 µF CERAMIC, C _{IN2} = 100 µF POLYMER-TANTALUM						
V _{OUT} (V)	V _{IN} (V)	C _{OUT1} Ceramic	C _{OUT2} BULK	VOLTAGE DEVIATION (mV)		RECOVERY TIME (µs)
				2.5 A LOAD STEP, (1 A/µs)	5 A LOAD STEP, (1 A/µs)	
0.6	5	500 µF	220 µF	25	60	100
	12	500 µF	220 µF	30	65	100
0.9	5	300 µF	220 µF	40	85	100
		300 µF	470 µF	35	70	110
	12	300 µF	220 µF	45	90	100
		300 µF	470 µF	35	75	110
1.2	5	200 µF	220 µF	55	110	110
		200 µF	470 µF	45	90	110
	12	200 µF	220 µF	55	110	110
		200 µF	470 µF	45	90	110
1.8	5	200 µF	220 µF	70	140	130
		200 µF	470 µF	60	120	140
	12	200 µF	220 µF	70	145	140
		200 µF	470 µF	55	120	150
3.3	5	100 µF	220 µF	115	230	200
	12	100 µF	220 µF	120	240	200

Transient Waveforms

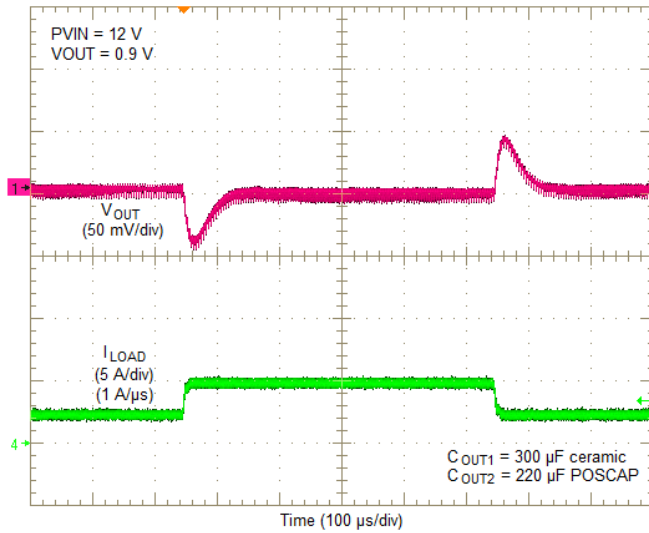

Figure 17. PVIN = 12V, VOUT = 0.9V, 2.5A Load Step

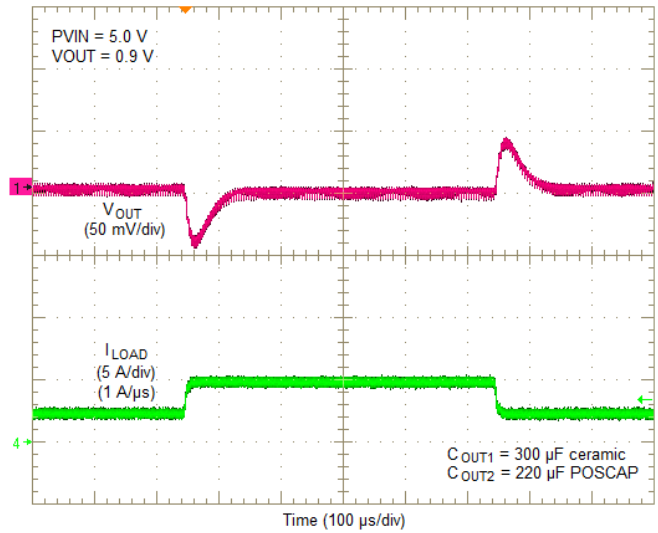

Figure 18. PVIN = 5V, VOUT = 0.9V, 2.5A Load Step

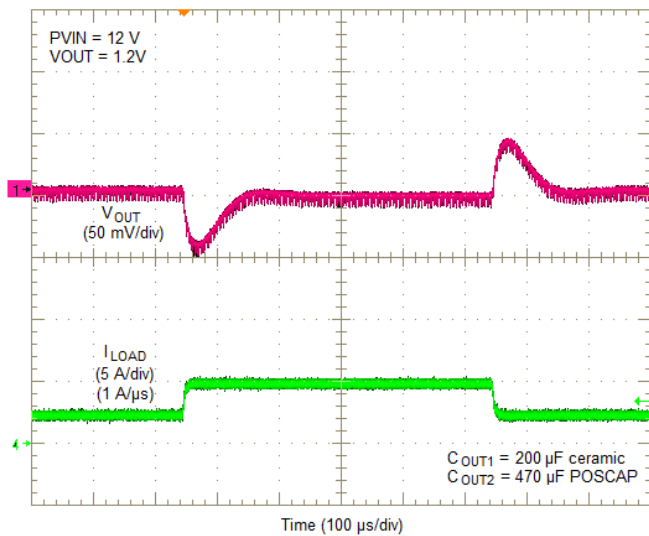

Figure 19. PVIN = 12V, VOUT = 1.2V, 2.5A Load Step

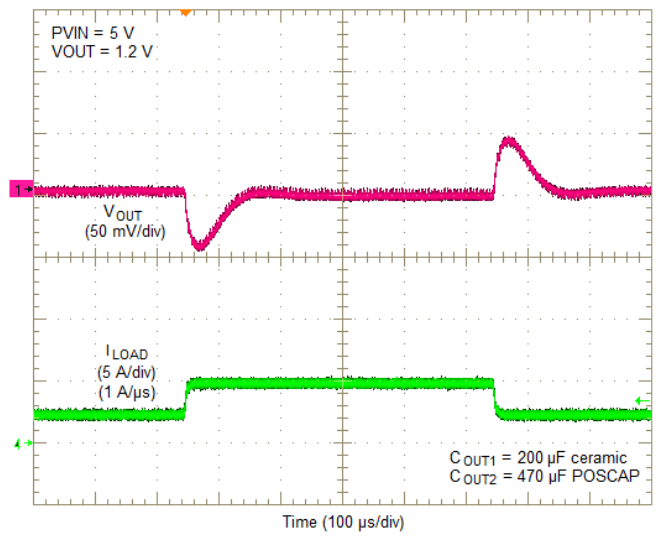

Figure 20. PVIN = 5V, VOUT = 1.2V, 2.5A Load Step

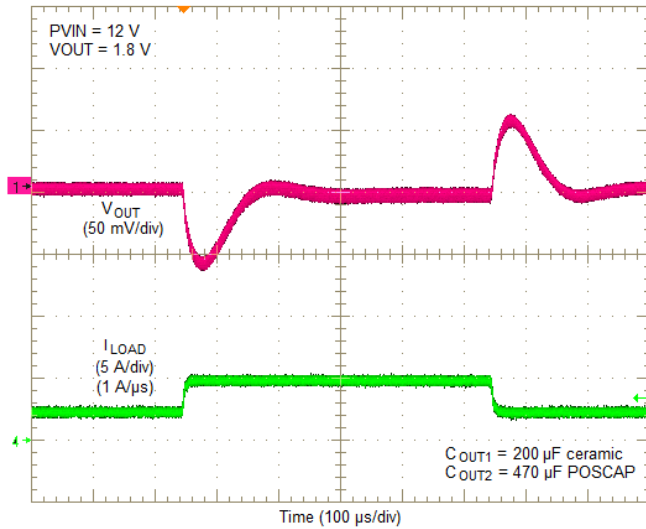

Figure 21. PVIN = 12V, VOUT = 1.8V, 2.5A Load Step

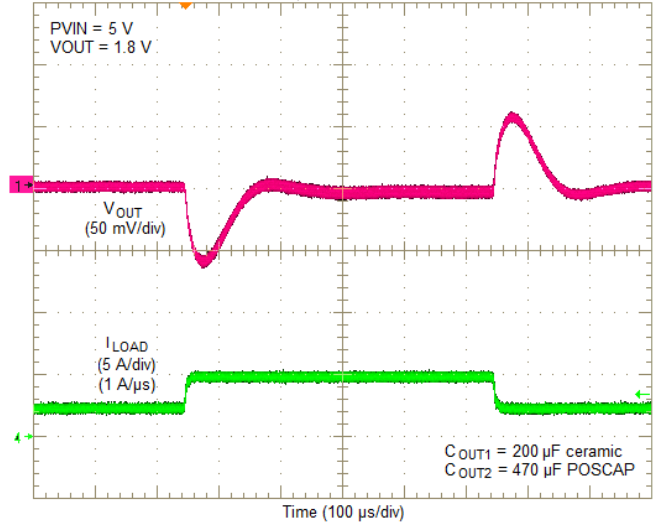

Figure 22. PVIN = 5V, VOUT = 1.8V, 2.5A Load Step

Application Schematics

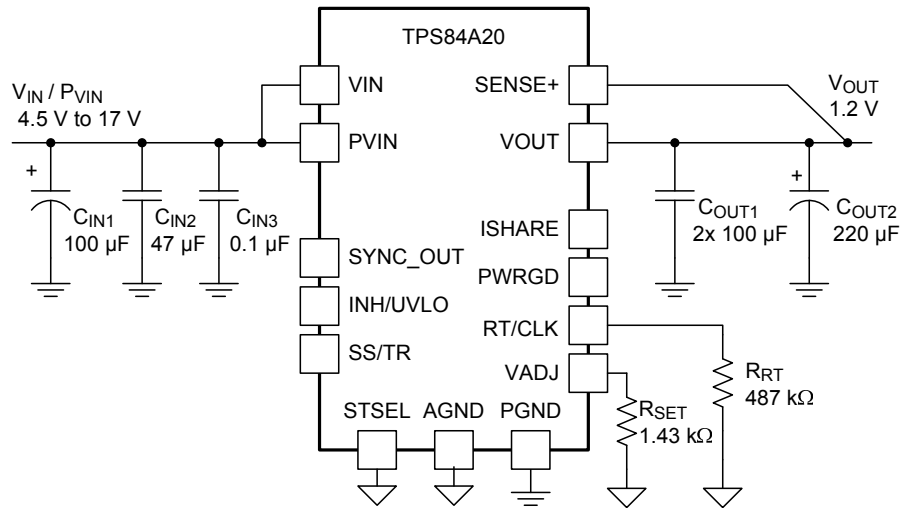

Figure 23. Typical Schematic
 PVIN = VIN = 4.5 V to 17 V, VOUT = 1.2 V

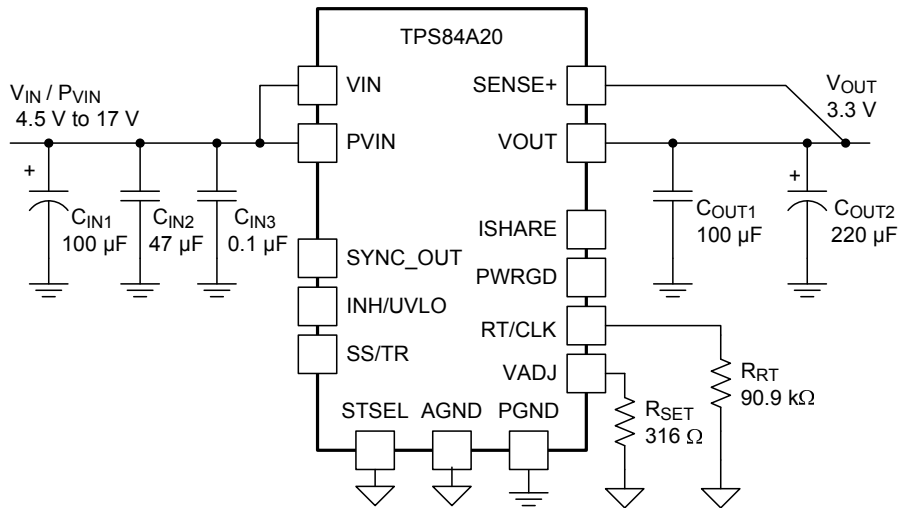

Figure 24. Typical Schematic
PVIN = VIN = 4.5 V to 17 V, VOUT = 3.3 V

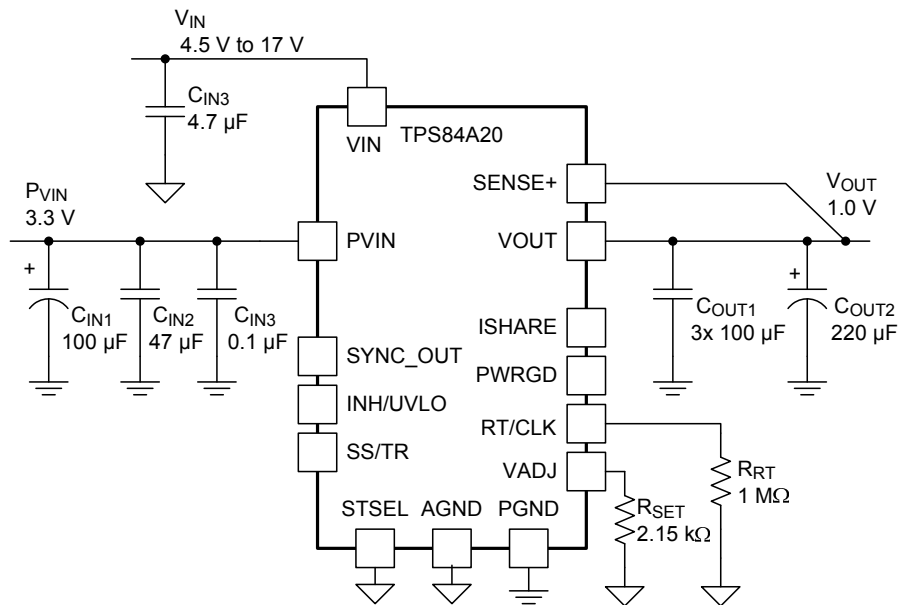

Figure 25. Typical Schematic
PVIN = 3.3 V, VIN = 4.5 V to 17 V, VOUT = 1.0 V

VIN and PVIN Input Voltage

The TPS84A20 allows for a variety of applications by using the VIN and PVIN pins together or separately. The VIN voltage supplies the internal control circuits of the device. The PVIN voltage provides the input voltage to the power converter system.

If tied together, the input voltage for the VIN pin and the PVIN pin can range from 4.5 V to 17 V. If using the VIN pin separately from the PVIN pin, the VIN pin must be greater than 4.5 V, and the PVIN pin can range from as low as 2.95 V to 17 V. When operating from a split rail, it is recommended to supply VIN from 5 V to 12 V, for best performance. A voltage divider connected to the INH/UVLO pin can adjust either input voltage UVLO appropriately. See the [Programmable Undervoltage Lockout \(UVLO\)](#) section of this datasheet for more information.

3.3 V PVIN Operation

Applications operating from a PVIN of 3.3 V must provide at least 4.5 V for VIN. It is recommended to supply VIN from 5 V to 12 V, for best performance. See application note, [SLVA561](#) for help creating 5 V from 3.3 V using a small, simple charge pump device.

Power Good (PWRGD)

The PWRGD pin is an open drain output. Once the voltage on the SENSE+ pin is between 95% and 104% of the set voltage, the PWRGD pin pull-down is released and the pin floats. The recommended pull-up resistor value is between 10 kΩ and 100 kΩ to a voltage source that is 5.5 V or less. The PWRGD pin is in a defined state once VIN is greater than 1.0 V, but with reduced current sinking capability. The PWRGD pin achieves full current sinking capability once the VIN pin is above 4.5V. The PWRGD pin is pulled low when the voltage on SENSE+ is lower than 91% or greater than 108% of the nominal set voltage. Also, the PWRGD pin is pulled low if the input UVLO or thermal shutdown is asserted, the INH pin is pulled low, or the SS/TR pin is below 1.4 V.

Light Load Efficiency (LLE)

The TPS84A20 operates in pulse skip mode at light load currents to improve efficiency and decrease power dissipation by reducing switching and gate drive losses.

These pulses may cause the output voltage to rise when there is no load to discharge the energy. For output voltages < 1.5 V, a minimum load is required. The amount of required load can be determined by [Equation 2](#). In most cases the minimum current drawn by the load circuit will be enough to satisfy this load. Applications requiring a load resistor to meet the minimum load, the added power dissipation will be ≤ 3.6 mW. A single 0402 size resistor across VOUT and PGND can be used.

$$I_{\text{MIN}} = 600 \mu\text{A} - \left(\frac{V_{\text{OUT}}}{1.43\text{k} + R_{\text{SET}}} \right) (\text{A}) \quad (2)$$

When $V_{\text{OUT}} = 0.6 \text{ V}$ and $R_{\text{SET}} = \text{OPEN}$, the minimum load current is 600 μA.

SYNC_OUT

The TPS84A20 provides a 180° out-of-phase clock signal for applications requiring synchronization. The SYNC_OUT pin produces a 50% duty cycle clock signal that is the same frequency as the device's switching frequency, but is 180° out of phase. Operating two devices 180° out of phase reduces input and output voltage ripple. The SYNC_OUT clock signal is compatible with other TPS84K devices that have a CLK input.

Parallel Operation

Up to six TPS84A20 devices can be paralleled for increased output current. Multiple connections must be made between the paralleled devices and the component selection is slightly different than for a stand-alone TPS84A20 device. A typical TPS84A20 parallel schematic is shown in [Figure 26](#). Refer to application note, [SLVA577](#) for information and design help when paralleling multiple TPS84A20 devices.

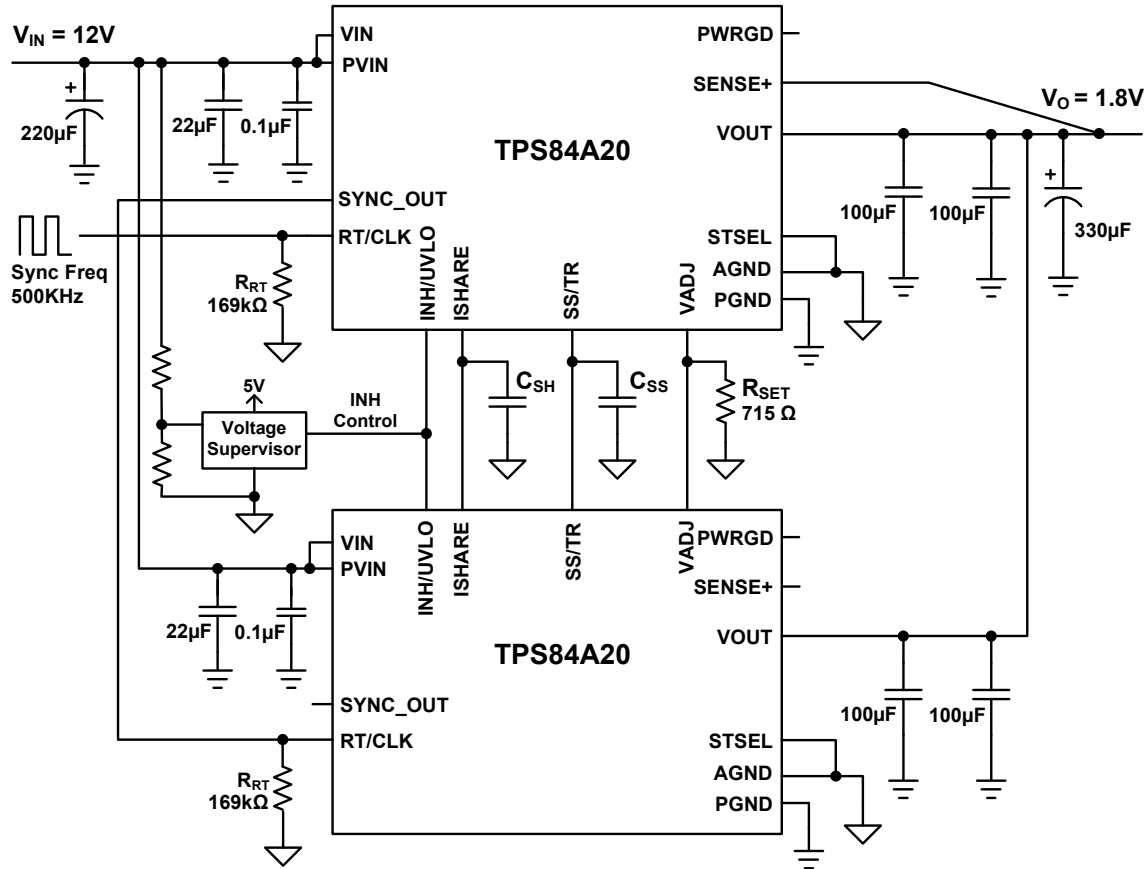

Figure 26. Typical TPS84A20 Parallel Schematic

Power-Up Characteristics

When configured as shown in the front page schematic, the TPS84A20 produces a regulated output voltage following the application of a valid input voltage. During the power-up, internal soft-start circuitry slows the rate that the output voltage rises, thereby limiting the amount of in-rush current that can be drawn from the input source. Figure 27 shows the start-up waveforms for a TPS84A20, operating from a 5-V input ($P_{VIN}=V_{IN}$) and with the output voltage adjusted to 1.8 V. Figure 28 shows the start-up waveforms for a TPS84A20 starting up into a pre-biased output voltage. The waveforms were measured with a 5-A constant current load.

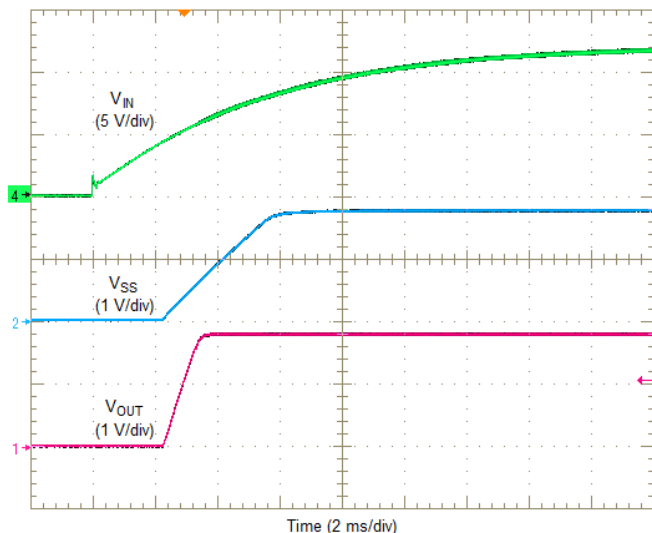

Figure 27. Start-Up Waveforms

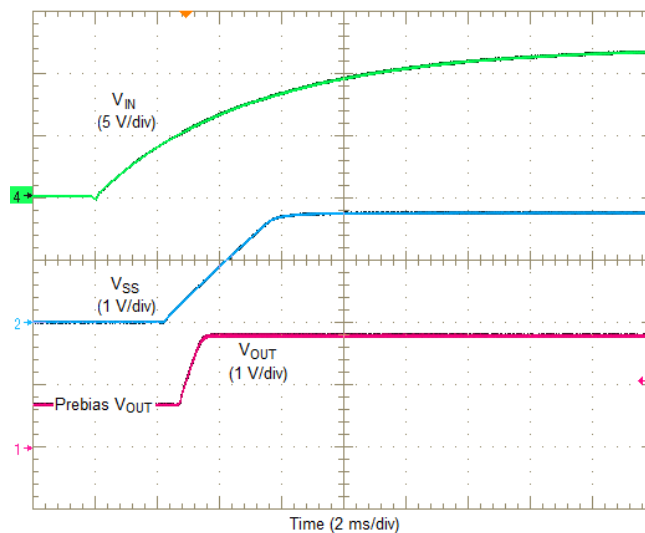

Figure 28. Start-up into Pre-bias

Pre-Biased Start-Up

The TPS84A20 has been designed to prevent the low-side MOSFET from discharging a pre-biased output. During pre-biased startup, the low-side MOSFET does not turn on until the high-side MOSFET has started switching. The high-side MOSFET does not start switching until the slow start voltage exceeds the voltage on the VADJ pin. Refer to Figure 28.

Remote Sense

The SENSE+ pin must be connected to V_{OUT} at the load, or at the device pins.

Connecting the SENSE+ pin to V_{OUT} at the load improves the load regulation performance of the device by allowing it to compensate for any I-R voltage drop between its output pins and the load. An I-R drop is caused by the high output current flowing through the small amount of pin and trace resistance. This should be limited to a maximum of 300 mV.

NOTE

The remote sense feature is not designed to compensate for the forward drop of nonlinear or frequency dependent components that may be placed in series with the converter output. Examples include OR-ing diodes, filter inductors, ferrite beads, and fuses. When these components are enclosed by the SENSE+ connection, they are effectively placed inside the regulation control loop, which can adversely affect the stability of the regulator.

Thermal Shutdown

The internal thermal shutdown circuitry forces the device to stop switching if the junction temperature exceeds 175°C typically. The device reinitiates the power up sequence when the junction temperature drops below 165°C typically.

Output On/Off Inhibit (INH)

The INH pin provides electrical on/off control of the device. Once the INH pin voltage exceeds the threshold voltage, the device starts operation. If the INH pin voltage is pulled below the threshold voltage, the regulator stops switching and enters low quiescent current state.

The INH pin has an internal pull-up current source, allowing the user to float the INH pin for enabling the device. If an application requires controlling the INH pin, use an open drain/collector device, or a suitable logic gate to interface with the pin.

Figure 29 shows the typical application of the inhibit function. The Inhibit control has its own internal pull-up to VIN potential. An open-collector or open-drain device is recommended to control this input.

Turning Q1 on applies a low voltage to the inhibit control (INH) pin and disables the output of the supply, shown in Figure 30. If Q1 is turned off, the supply executes a soft-start power-up sequence, as shown in Figure 31. A regulated output voltage is produced within 2 ms. The waveforms were measured with a 5-A constant current load.

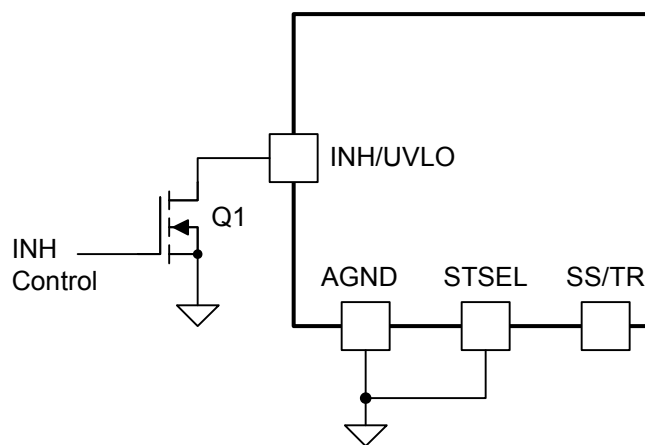

Figure 29. Typical Inhibit Control

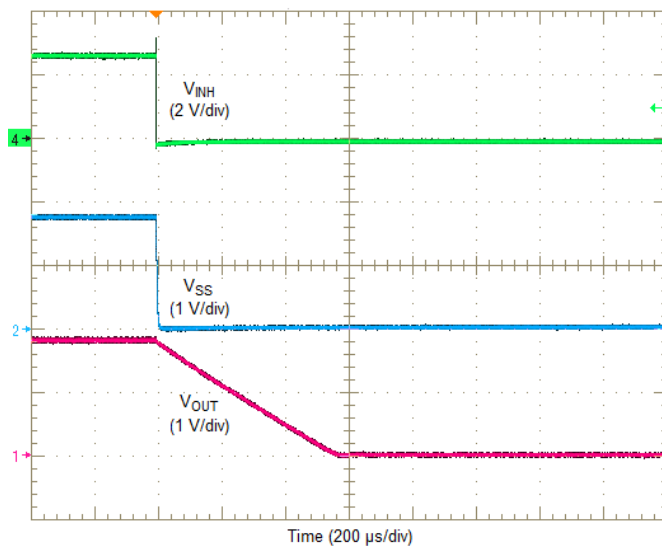

Figure 30. Inhibit Turn-Off

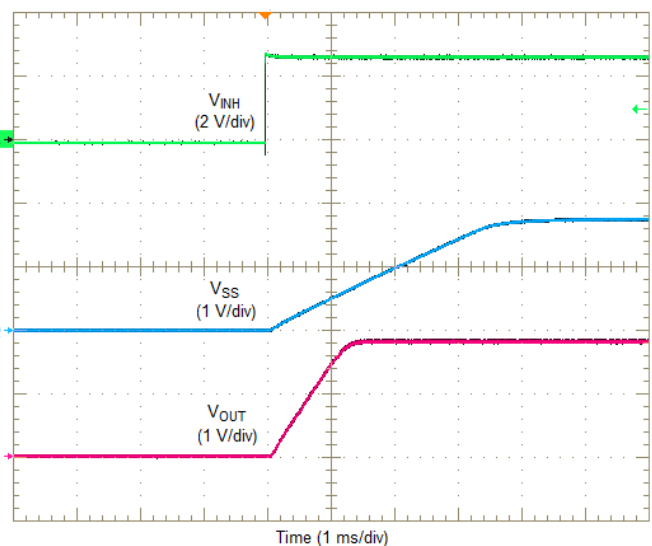

Figure 31. Inhibit Turn-On

Slow Start (SS/TR)

Connecting the STSEL pin to AGND and leaving SS/TR pin open enables the internal SS capacitor with a slow start interval of approximately 1.2 ms. Adding additional capacitance between the SS pin and AGND increases the slow start time. Increasing the slow start time will reduce inrush current. Table 6 shows an additional SS capacitor connected to the SS/TR pin and the STSEL pin connected to AGND. See Table 6 below for SS capacitor values and timing interval.

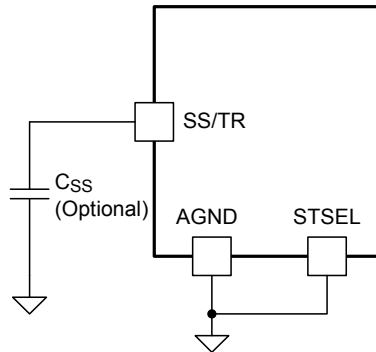

Figure 32. Slow-Start Capacitor (C_{SS}) and STSEL Connection

Table 6. Slow-Start Capacitor Values and Slow-Start Time

C _{SS} (nF)	open	3.3	4.7	10	15	22	33
SS Time (msec)	1.2	2.1	2.5	3.8	5.1	7.0	9.8

Overcurrent Protection

For protection against load faults, the TPS84A20 incorporates output overcurrent protection. The overcurrent protection mode can be selected using the OCP_SEL pin. Leaving the OCP_SEL pin open selects hiccup mode and connecting it to AGND selects cycle-by-cycle mode. In hiccup mode, applying a load that exceeds the regulator's overcurrent threshold causes the regulated output to shut down. Following shutdown, the module periodically attempts to recover by initiating a soft-start power-up as shown in [Figure 33](#). This is described as a hiccup mode of operation, whereby the module continues in a cycle of successive shutdown and power up until the load fault is removed. During this period, the average current flowing into the fault is significantly reduced which reduces power dissipation. Once the fault is removed, the module automatically recovers and returns to normal operation as shown in [Figure 34](#).

In cycle-by-cycle mode, applying a load that exceeds the regulator's overcurrent threshold limits the output current and reduces the output voltage as shown in [Figure 35](#). During this period, the current flowing into the fault remains high causing the power dissipation to stay high as well. Once the overcurrent condition is removed, the output voltage returns to the set-point voltage as shown in [Figure 36](#).

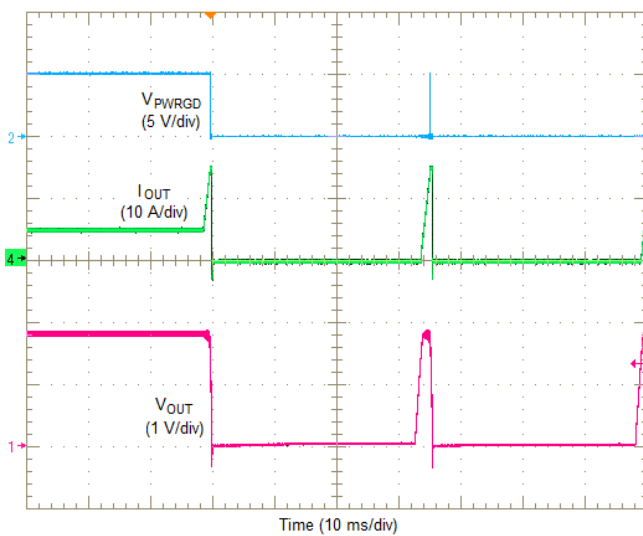

Figure 33. Overcurrent Limiting (Hiccup)

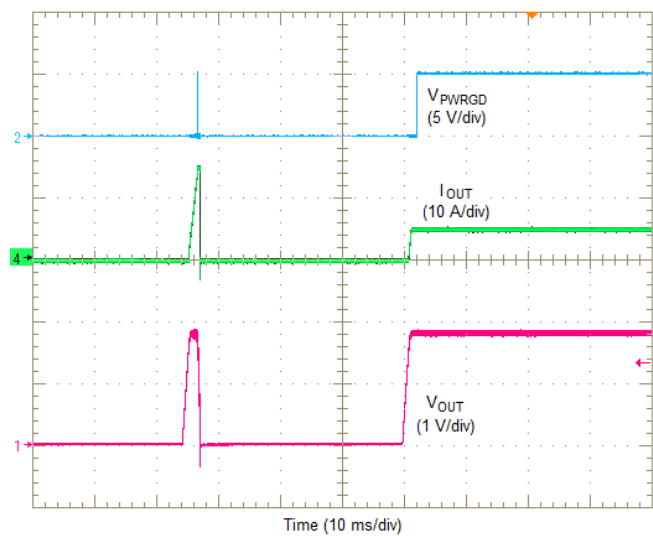

Figure 34. Removal of Overcurrent (Hiccup)

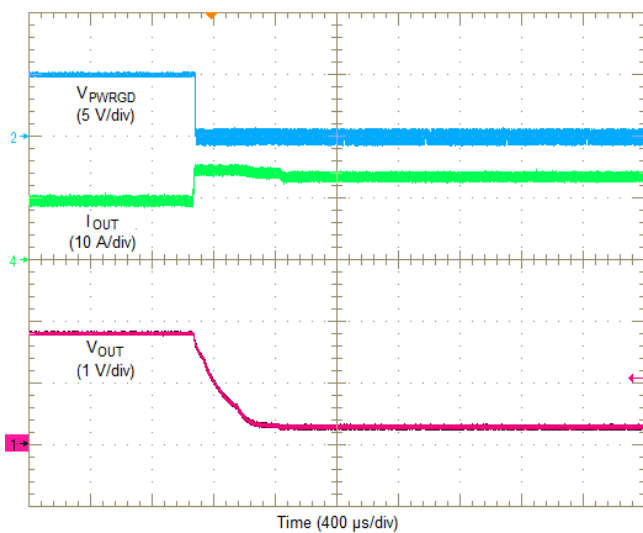

Figure 35. Overcurrent Limiting (Cycle-by-Cycle)

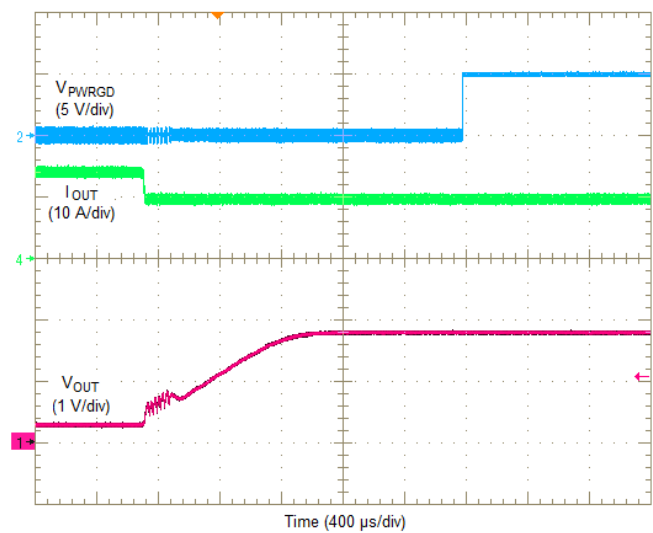

Figure 36. Removal of Overcurrent (Cycle-by-Cycle)

Synchronization (CLK)

An internal phase locked loop (PLL) has been implemented to allow synchronization between 200 kHz and 1200 kHz, and to easily switch from RT mode to CLK mode. To implement the synchronization feature, connect a square wave clock signal to the RT/CLK pin with a duty cycle between 20% to 80%. The clock signal amplitude must transition lower than 0.5 V and higher than 2.0 V. The start of the switching cycle is synchronized to the falling edge of RT/CLK pin. In applications where both RT mode and CLK mode are needed, the device can be configured as shown in [Figure 37](#). Adding a series capacitor and resistor (470 pF and 1 kΩ) to the input of the RT/CLK pin will AC-couple the clock signal into the pin. This will prevent a sustained high or low clock signal from over-riding the RT resistor.

Before the external clock is present, the device works in RT mode and the switching frequency is set by RT resistor. When the external clock is present, the CLK mode overrides the RT mode. The first time the CLK pin is pulled above the RT/CLK high threshold (2.0 V), the device switches from RT mode to CLK mode and the RT/CLK pin becomes high impedance as the PLL starts to lock onto the frequency of the external clock. It is not recommended to switch from CLK mode back to RT mode because the internal switching frequency drops to 100 kHz first before returning to the switching frequency set by the RT resistor (R_{RT}).

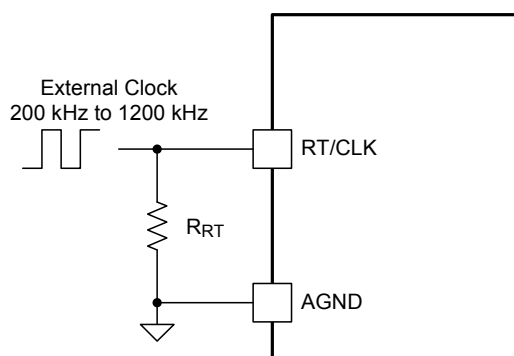

Figure 37. RT/CLK Configuration

The synchronization frequency must be selected based on the output voltages of the devices being synchronized. [Table 7](#) shows the allowable frequencies for a given range of output voltages. For the most efficient solution, always synchronize to the lowest allowable frequency. For example, an application requires synchronizing three TPS84A20 devices with output voltages of 1.0 V, 1.2 V and 1.8 V, all powered from $P_{VIN} = 12$ V. [Table 7](#) shows that all three output voltages should be synchronized to 300 kHz.

Table 7. Synchronization Frequency vs Output Voltage

SYNCHRONIZATION FREQUENCY (kHz)	$P_{VIN} = 12$ V		$P_{VIN} = 5$ V	
	V_{OUT} RANGE (V)		V_{OUT} RANGE (V)	
	MIN	MAX	MIN	MAX
200	0.6	1.3	0.6	1.5
300	0.8	2.0	0.6	4.3
400	1.1	2.5	0.6	4.3
500	1.4	3.4	0.6	4.3
600	1.6	5.0	0.7	4.3
700	1.9	5.5	0.8	4.3
800	2.1	5.5	0.9	4.3
900	2.4	5.5	1.0	4.3
1000	2.7	5.5	1.1	4.3
1100	2.9	5.5	1.3	4.3
1200	3.2	5.5	1.4	4.3

Sequencing (SS/TR)

Many of the common power supply sequencing methods can be implemented using the SS/TR, INH and PWRGD pins. The sequential method is illustrated in Figure 38 using two TPS84A20 devices. The PWRGD pin of the first device is coupled to the INH pin of the second device which enables the second power supply once the primary supply reaches regulation. Figure 39 shows sequential turn-on waveforms of two TPS84A20 devices.

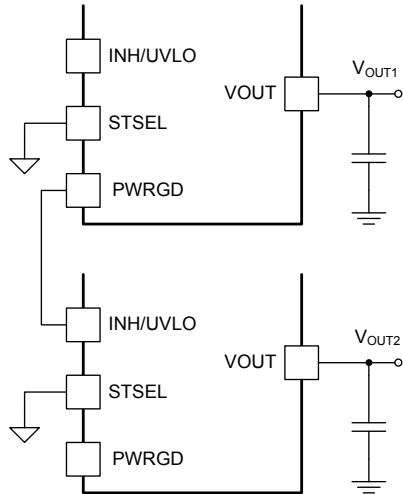

Figure 38. Sequencing Schematic

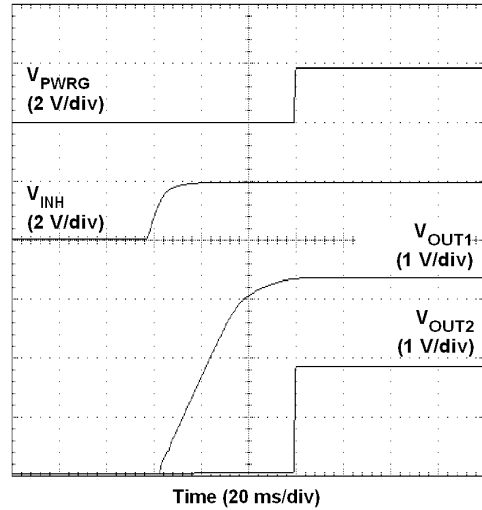

Figure 39. Sequencing Waveforms

Simultaneous power supply sequencing can be implemented by connecting the resistor network of R1 and R2 shown in Figure 40 to the output of the power supply that needs to be tracked or to another voltage reference source. The tracking voltage must exceed 750mV before V_{OUT2} reaches its set-point voltage. Figure 41 shows simultaneous turn-on waveforms of two TPS84A20 devices. Use Equation 3 and Equation 4 to calculate the values of R1 and R2.

$$R1 = \frac{(V_{OUT2} \times 12.6)}{0.6} \text{ (k}\Omega\text{)} \tag{3}$$

$$R2 = \frac{0.6 \times R1}{(V_{OUT2} - 0.6)} \text{ (k}\Omega\text{)} \tag{4}$$

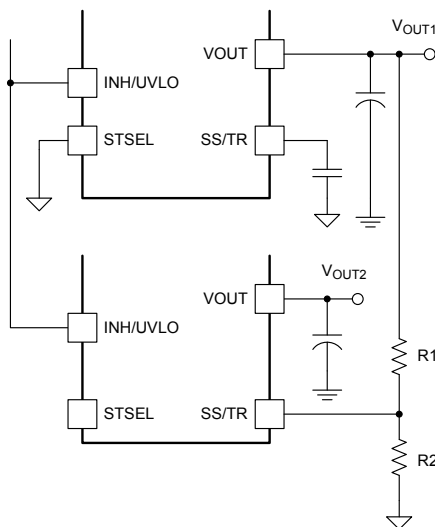

Figure 40. Simultaneous Tracking Schematic

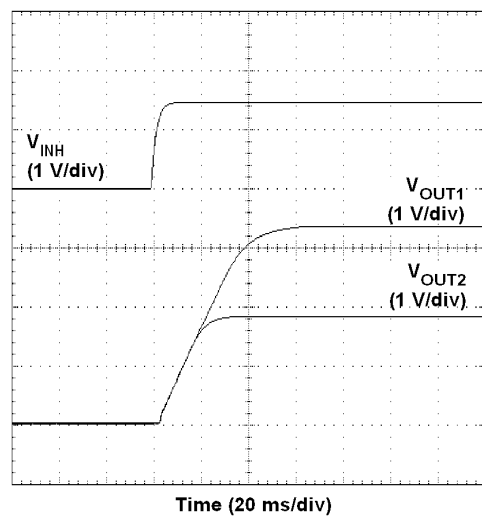

Figure 41. Simultaneous Tracking Waveforms

Programmable Undervoltage Lockout (UVLO)

The TPS84A20 implements internal UVLO circuitry on the VIN pin. The device is disabled when the VIN pin voltage falls below the internal VIN UVLO threshold. The internal VIN UVLO rising threshold is 4.5 V(max) with a typical hysteresis of 150 mV.

If an application requires either a higher UVLO threshold on the VIN pin or a higher UVLO threshold for a combined VIN and PVIN, then the UVLO pin can be configured as shown in Figure 42 or Figure 43. Table 8 lists standard values for R_{UVLO1} and R_{UVLO2} to adjust the VIN UVLO voltage up.

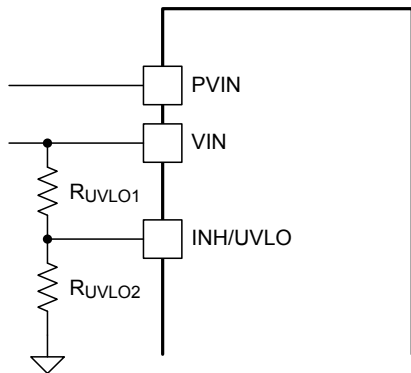

Figure 42. Adjustable VIN UVLO

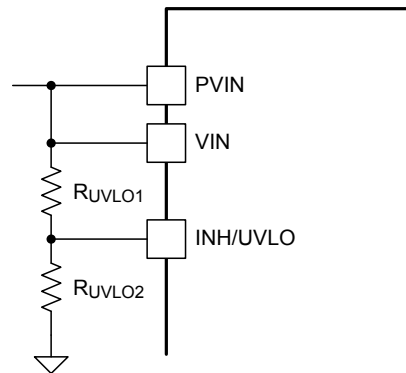

Figure 43. Adjustable VIN and PVIN Undervoltage Lockout

Table 8. Standard Resistor values for Adjusting VIN UVLO

VIN UVLO (V)	5.0	5.5	6.0	6.5	7.0	7.5	8.0	8.5	9.0	9.5	10.0
R_{UVLO1} (k Ω)	68.1	68.1	68.1	68.1	68.1	68.1	68.1	68.1	68.1	68.1	68.1
R_{UVLO2} (k Ω)	21.5	18.7	16.9	15.4	14.0	13.0	12.1	11.3	10.5	9.76	9.31
Hysteresis (mV)	400	415	430	450	465	480	500	515	530	550	565

For a split rail application, if a secondary UVLO on PVIN is required, VIN must be $\geq 4.5V$. Figure 44 shows the PVIN UVLO configuration. Use Table 9 to select R_{UVLO1} and R_{UVLO2} for PVIN. If PVIN UVLO is set for less than 3.0 V, a 5.1-V zener diode should be added to clamp the voltage on the UVLO pin below 6 V.

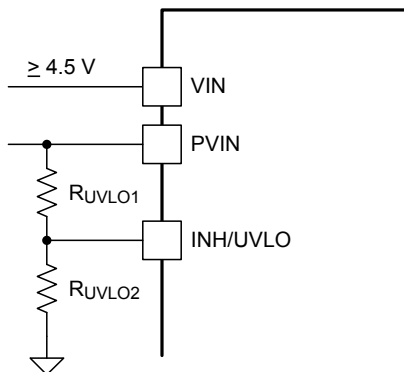

Figure 44. Adjustable PVIN Undervoltage Lockout, (VIN ≥ 4.5 V)

Table 9. Standard Resistor Values for Adjusting PVIN UVLO, (VIN ≥ 4.5 V)

PVIN UVLO (V)	2.9	3.0	3.5	4.0	4.5	For higher PVIN UVLO voltages see Table 8 for resistor values
R_{UVLO1} (k Ω)	68.1	68.1	68.1	68.1	68.1	
R_{UVLO2} (k Ω)	47.5	44.2	34.8	28.7	24.3	
Hysteresis (mV)	330	335	350	365	385	

Layout Considerations

To achieve optimal electrical and thermal performance, an optimized PCB layout is required. [Figure 45](#) thru [Figure 48](#), shows a typical PCB layout. Some considerations for an optimized layout are:

- Use large copper areas for power planes (PVIN, VOUT, and PGND) to minimize conduction loss and thermal stress.
- Place ceramic input and output capacitors close to the device pins to minimize high frequency noise.
- Locate additional output capacitors between the ceramic capacitor and the load.
- Keep AGND and PGND separate from one another.
- Place R_{SET} , R_{RT} , and C_{SS} as close as possible to their respective pins.
- Use multiple vias to connect the power planes to internal layers.

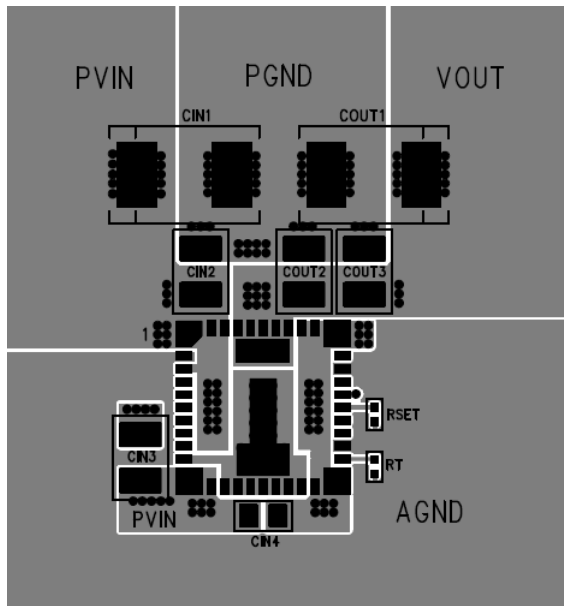

Figure 45. Typical Top-Layer Layout

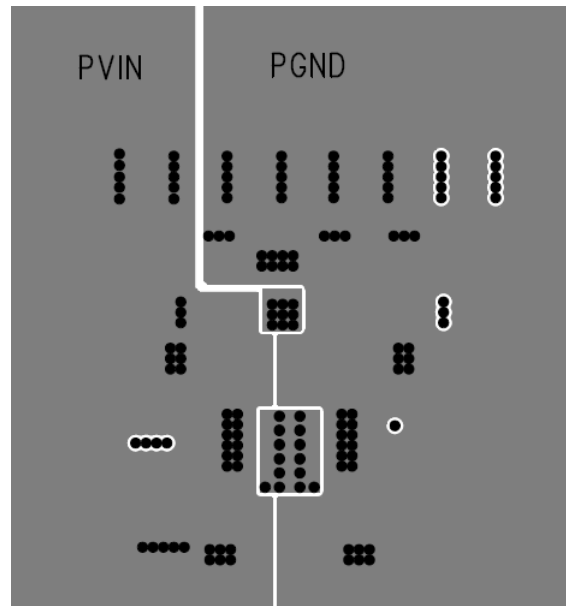

Figure 46. Typical Layer-2 Layout

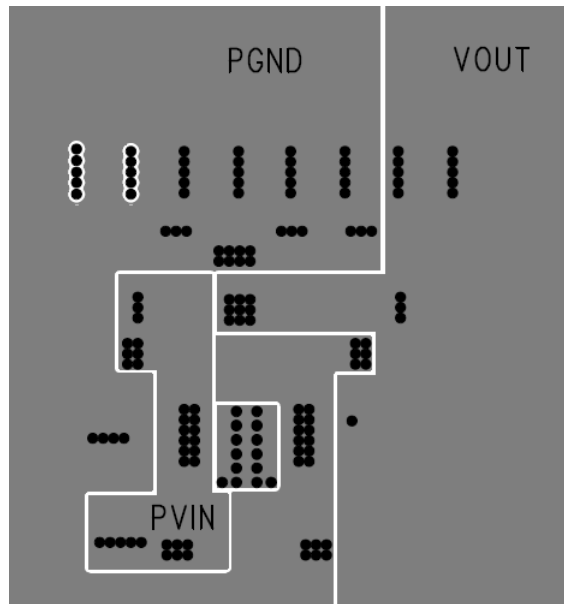

Figure 47. Typical Layer 3 Layout

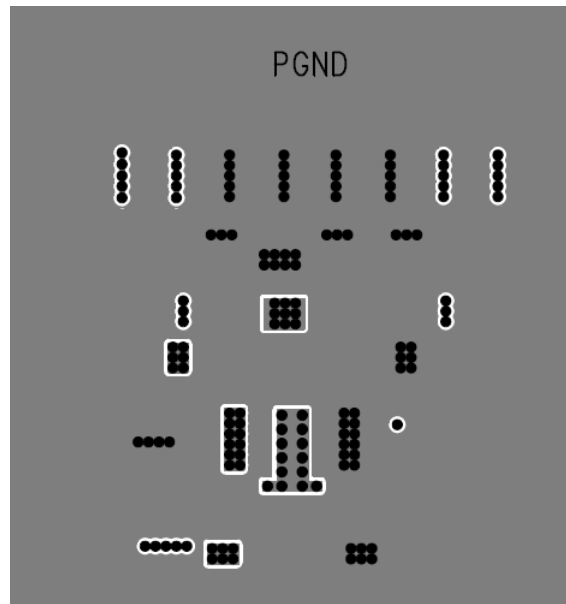

Figure 48. Typical Bottom-Layer Layout

EMI

The TPS84A20 is compliant with EN55022 Class B radiated emissions. [Figure 49](#) and [Figure 50](#) show typical examples of radiated emissions plots for the TPS84A20 operating from 5V and 12V respectively. Both graphs include the plots of the antenna in the horizontal and vertical positions.

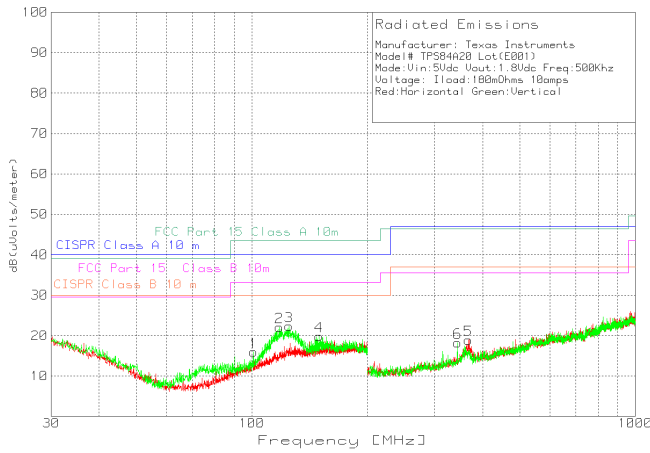

Figure 49. Radiated Emissions 5-V Input, 1.8-V Output, 10-A Load (EN55022 Class B)

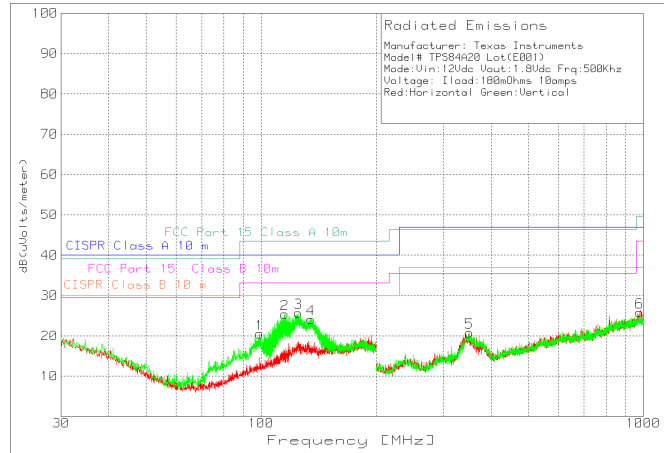

Figure 50. Radiated Emissions 12-V Input, 1.8-V Output, 10-A Load (EN55022 Class B)

PACKAGING INFORMATION

Orderable Device	Status (1)	Package Type	Package Drawing	Pins	Package Qty	Eco Plan (2)	Lead/Ball Finish (6)	MSL Peak Temp (3)	Op Temp (°C)	Device Marking (4/5)	Samples
TPS84A20RVQR	ACTIVE	B3QFN	RVQ	42	500	RoHS (In Work) & Green (In Work)	CU NIPDAU	Level-3-260C-168 HR	-40 to 85	(54020 ~ TPS84A20)	Samples
TPS84A20RVQT	ACTIVE	B3QFN	RVQ	42	250	RoHS (In Work) & Green (In Work)	CU NIPDAU	Level-3-260C-168 HR	-40 to 85	(54020 ~ TPS84A20)	Samples

(1) The marketing status values are defined as follows:

ACTIVE: Product device recommended for new designs.

LIFEBUY: TI has announced that the device will be discontinued, and a lifetime-buy period is in effect.

NRND: Not recommended for new designs. Device is in production to support existing customers, but TI does not recommend using this part in a new design.

PREVIEW: Device has been announced but is not in production. Samples may or may not be available.

OBSELETE: TI has discontinued the production of the device.

(2) **RoHS:** TI defines "RoHS" to mean semiconductor products that are compliant with the current EU RoHS requirements for all 10 RoHS substances, including the requirement that RoHS substance do not exceed 0.1% by weight in homogeneous materials. Where designed to be soldered at high temperatures, "RoHS" products are suitable for use in specified lead-free processes. TI may reference these types of products as "Pb-Free".

RoHS Exempt: TI defines "RoHS Exempt" to mean products that contain lead but are compliant with EU RoHS pursuant to a specific EU RoHS exemption.

Green: TI defines "Green" to mean the content of Chlorine (Cl) and Bromine (Br) based flame retardants meet JS709B low halogen requirements of <=1000ppm threshold. Antimony trioxide based flame retardants must also meet the <=1000ppm threshold requirement.

(3) MSL, Peak Temp. - The Moisture Sensitivity Level rating according to the JEDEC industry standard classifications, and peak solder temperature.

(4) There may be additional marking, which relates to the logo, the lot trace code information, or the environmental category on the device.

(5) Multiple Device Markings will be inside parentheses. Only one Device Marking contained in parentheses and separated by a "~" will appear on a device. If a line is indented then it is a continuation of the previous line and the two combined represent the entire Device Marking for that device.

(6) Lead/Ball Finish - Orderable Devices may have multiple material finish options. Finish options are separated by a vertical ruled line. Lead/Ball Finish values may wrap to two lines if the finish value exceeds the maximum column width.

Important Information and Disclaimer:The information provided on this page represents TI's knowledge and belief as of the date that it is provided. TI bases its knowledge and belief on information provided by third parties, and makes no representation or warranty as to the accuracy of such information. Efforts are underway to better integrate information from third parties. TI has taken and continues to take reasonable steps to provide representative and accurate information but may not have conducted destructive testing or chemical analysis on incoming materials and chemicals. TI and TI suppliers consider certain information to be proprietary, and thus CAS numbers and other limited information may not be available for release.

In no event shall TI's liability arising out of such information exceed the total purchase price of the TI part(s) at issue in this document sold by TI to Customer on an annual basis.

IMPORTANT NOTICE

Texas Instruments Incorporated (TI) reserves the right to make corrections, enhancements, improvements and other changes to its semiconductor products and services per JESD46, latest issue, and to discontinue any product or service per JESD48, latest issue. Buyers should obtain the latest relevant information before placing orders and should verify that such information is current and complete.

TI's published terms of sale for semiconductor products (<http://www.ti.com/sc/docs/stdterms.htm>) apply to the sale of packaged integrated circuit products that TI has qualified and released to market. Additional terms may apply to the use or sale of other types of TI products and services.

Reproduction of significant portions of TI information in TI data sheets is permissible only if reproduction is without alteration and is accompanied by all associated warranties, conditions, limitations, and notices. TI is not responsible or liable for such reproduced documentation. Information of third parties may be subject to additional restrictions. Resale of TI products or services with statements different from or beyond the parameters stated by TI for that product or service voids all express and any implied warranties for the associated TI product or service and is an unfair and deceptive business practice. TI is not responsible or liable for any such statements.

Buyers and others who are developing systems that incorporate TI products (collectively, "Designers") understand and agree that Designers remain responsible for using their independent analysis, evaluation and judgment in designing their applications and that Designers have full and exclusive responsibility to assure the safety of Designers' applications and compliance of their applications (and of all TI products used in or for Designers' applications) with all applicable regulations, laws and other applicable requirements. Designer represents that, with respect to their applications, Designer has all the necessary expertise to create and implement safeguards that (1) anticipate dangerous consequences of failures, (2) monitor failures and their consequences, and (3) lessen the likelihood of failures that might cause harm and take appropriate actions. Designer agrees that prior to using or distributing any applications that include TI products, Designer will thoroughly test such applications and the functionality of such TI products as used in such applications.

TI's provision of technical, application or other design advice, quality characterization, reliability data or other services or information, including, but not limited to, reference designs and materials relating to evaluation modules, (collectively, "TI Resources") are intended to assist designers who are developing applications that incorporate TI products; by downloading, accessing or using TI Resources in any way, Designer (individually or, if Designer is acting on behalf of a company, Designer's company) agrees to use any particular TI Resource solely for this purpose and subject to the terms of this Notice.

TI's provision of TI Resources does not expand or otherwise alter TI's applicable published warranties or warranty disclaimers for TI products, and no additional obligations or liabilities arise from TI providing such TI Resources. TI reserves the right to make corrections, enhancements, improvements and other changes to its TI Resources. TI has not conducted any testing other than that specifically described in the published documentation for a particular TI Resource.

Designer is authorized to use, copy and modify any individual TI Resource only in connection with the development of applications that include the TI product(s) identified in such TI Resource. NO OTHER LICENSE, EXPRESS OR IMPLIED, BY ESTOPPEL OR OTHERWISE TO ANY OTHER TI INTELLECTUAL PROPERTY RIGHT, AND NO LICENSE TO ANY TECHNOLOGY OR INTELLECTUAL PROPERTY RIGHT OF TI OR ANY THIRD PARTY IS GRANTED HEREIN, including but not limited to any patent right, copyright, mask work right, or other intellectual property right relating to any combination, machine, or process in which TI products or services are used. Information regarding or referencing third-party products or services does not constitute a license to use such products or services, or a warranty or endorsement thereof. Use of TI Resources may require a license from a third party under the patents or other intellectual property of the third party, or a license from TI under the patents or other intellectual property of TI.

TI RESOURCES ARE PROVIDED "AS IS" AND WITH ALL FAULTS. TI DISCLAIMS ALL OTHER WARRANTIES OR REPRESENTATIONS, EXPRESS OR IMPLIED, REGARDING RESOURCES OR USE THEREOF, INCLUDING BUT NOT LIMITED TO ACCURACY OR COMPLETENESS, TITLE, ANY EPIDEMIC FAILURE WARRANTY AND ANY IMPLIED WARRANTIES OF MERCHANTABILITY, FITNESS FOR A PARTICULAR PURPOSE, AND NON-INFRINGEMENT OF ANY THIRD PARTY INTELLECTUAL PROPERTY RIGHTS. TI SHALL NOT BE LIABLE FOR AND SHALL NOT DEFEND OR INDEMNIFY DESIGNER AGAINST ANY CLAIM, INCLUDING BUT NOT LIMITED TO ANY INFRINGEMENT CLAIM THAT RELATES TO OR IS BASED ON ANY COMBINATION OF PRODUCTS EVEN IF DESCRIBED IN TI RESOURCES OR OTHERWISE. IN NO EVENT SHALL TI BE LIABLE FOR ANY ACTUAL, DIRECT, SPECIAL, COLLATERAL, INDIRECT, PUNITIVE, INCIDENTAL, CONSEQUENTIAL OR EXEMPLARY DAMAGES IN CONNECTION WITH OR ARISING OUT OF TI RESOURCES OR USE THEREOF, AND REGARDLESS OF WHETHER TI HAS BEEN ADVISED OF THE POSSIBILITY OF SUCH DAMAGES.

Unless TI has explicitly designated an individual product as meeting the requirements of a particular industry standard (e.g., ISO/TS 16949 and ISO 26262), TI is not responsible for any failure to meet such industry standard requirements.

Where TI specifically promotes products as facilitating functional safety or as compliant with industry functional safety standards, such products are intended to help enable customers to design and create their own applications that meet applicable functional safety standards and requirements. Using products in an application does not by itself establish any safety features in the application. Designers must ensure compliance with safety-related requirements and standards applicable to their applications. Designer may not use any TI products in life-critical medical equipment unless authorized officers of the parties have executed a special contract specifically governing such use. Life-critical medical equipment is medical equipment where failure of such equipment would cause serious bodily injury or death (e.g., life support, pacemakers, defibrillators, heart pumps, neurostimulators, and implantables). Such equipment includes, without limitation, all medical devices identified by the U.S. Food and Drug Administration as Class III devices and equivalent classifications outside the U.S.

TI may expressly designate certain products as completing a particular qualification (e.g., Q100, Military Grade, or Enhanced Product). Designers agree that it has the necessary expertise to select the product with the appropriate qualification designation for their applications and that proper product selection is at Designers' own risk. Designers are solely responsible for compliance with all legal and regulatory requirements in connection with such selection.

Designer will fully indemnify TI and its representatives against any damages, costs, losses, and/or liabilities arising out of Designer's non-compliance with the terms and provisions of this Notice.