

## ISO772x-Q1 High-Speed, Robust EMC Reinforced Dual-Channel Digital Isolators

### 1 Features

- Qualified for Automotive Applications
- AEC-Q100 Qualified With the Following Results:
  - Device Temperature Grade 1: –40°C to +125°C Ambient Operating Temperature Range
  - Device HBM ESD Classification Level 3A
  - Device CDM ESD Classification Level C6
- Signaling Rate: Up to 100 Mbps
- Wide Supply Range: 2.25 V to 5.5 V
- 2.25-V to 5.5-V Level Translation
- Default Output *High* and *Low* Options
- Low Power Consumption, Typical 1.7 mA per Channel at 1 Mbps
- Low Propagation Delay: 11 ns Typical (5-V Supplies)
- High CMTI:  $\pm 100$  kV/ $\mu$ s Typical
- Robust Electromagnetic Compatibility (EMC)
  - System-Level ESD, EFT, and Surge Immunity
  - Low Emissions
- Isolation Barrier Life: >40 Years
- Wide-SOIC (DW-16) and Narrow-SOIC (D-8) Package Options
- Safety-Related Certifications:
  - VDE Reinforced Insulation according to DIN V VDE V 0884-10 (VDE V 0884-10):2006-12
  - 5000 V<sub>RMS</sub> (DW) and 3000 V<sub>RMS</sub> (D) Isolation Rating per UL 1577
  - CSA Component Acceptance Notice 5A, IEC 60950-1 and IEC 60601-1 End Equipment Standards
  - CQC Certification per GB4943.1-2011
  - TUV Certification according to EN 60950-1 and EN 61010-1
  - VDE, UL, CSA, and TUV Certifications for DW Package Complete; All Other Certifications Planned

### 2 Applications

- Hybrid Electric Vehicles
- Motor Control
- Power Supplies
- Solar Inverters

### 3 Description

The ISO772x-Q1 devices are high-performance, dual-channel digital isolators with 5000 V<sub>RMS</sub> (DW package) and 3000 V<sub>RMS</sub> (D package) isolation ratings per UL 1577. These devices are also certified by VDE, TUV, CSA, and CQC.

The ISO772x-Q1 devices provide high electromagnetic immunity and low emissions at low power consumption, while isolating CMOS or LVCMOS digital I/Os. Each isolation channel has a logic input and output buffer separated by a silicon dioxide (SiO<sub>2</sub>) insulation barrier. The ISO7720-Q1 device has both channels in the same direction while the -Q1 device has both channels in the opposite direction. In the event of input power or signal loss, the default output is *high* for devices without suffix F and *low* for devices with suffix F. See the [Device Functional Modes](#) section for further details.

Used in conjunction with isolated power supplies, these devices help prevent noise currents on a data bus or other circuits from entering the local ground and interfering with or damaging sensitive circuitry. Through innovative chip design and layout techniques, the electromagnetic compatibility of the ISO772x-Q1 devices has been significantly enhanced to ease system-level ESD, EFT, surge, and emissions compliance. The ISO772x-Q1 family of devices is available in 16-pin SOIC wide-body (DW) and 8-pin SOIC narrow-body (D) packages.

#### Device Information<sup>(1)</sup>

PART NUMBER	PACKAGE	BODY SIZE (NOM)
ISO7720-Q1	SOIC (D)	4.90 mm x 3.91 mm
ISO7721-Q1	SOIC (DW)	10.30 mm x 7.50 mm

(1) For all available packages, see the orderable addendum at the end of the datasheet.

#### Simplified Schematic

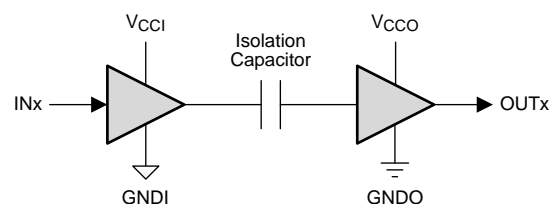

Copyright © 2016, Texas Instruments Incorporated

V<sub>CCI</sub> and GNDI are supply and ground connections respectively for the input channels.

V<sub>CCO</sub> and GNDO are supply and ground connections respectively for the output channels.



## Table of Contents

<b>1 Features</b> .....	<b>1</b>	6.19 Typical Characteristics .....	<b>13</b>
<b>2 Applications</b> .....	<b>1</b>	<b>7 Parameter Measurement Information</b> .....	<b>15</b>
<b>3 Description</b> .....	<b>1</b>	<b>8 Detailed Description</b> .....	<b>16</b>
<b>4 Revision History</b> .....	<b>2</b>	8.1 Overview .....	<b>16</b>
<b>5 Pin Configuration and Functions</b> .....	<b>3</b>	8.2 Functional Block Diagram .....	<b>16</b>
<b>6 Specifications</b> .....	<b>4</b>	8.3 Feature Description .....	<b>17</b>
6.1 Absolute Maximum Ratings .....	<b>4</b>	8.4 Device Functional Modes .....	<b>18</b>
6.2 ESD Ratings .....	<b>4</b>	<b>9 Applications and Implementation</b> .....	<b>19</b>
6.3 Recommended Operating Conditions .....	<b>4</b>	9.1 Application Information .....	<b>19</b>
6.4 Thermal Information .....	<b>5</b>	9.2 Typical Application .....	<b>19</b>
6.5 Power Ratings .....	<b>5</b>	<b>10 Power Supply Recommendations</b> .....	<b>21</b>
6.6 Insulation Specifications .....	<b>6</b>	<b>11 Layout</b> .....	<b>21</b>
6.7 Safety-Related Certifications .....	<b>7</b>	11.1 Layout Guidelines .....	<b>21</b>
6.8 Safety Limiting Values .....	<b>7</b>	11.2 Layout Example .....	<b>21</b>
6.9 Electrical Characteristics—5-V Supply .....	<b>8</b>	<b>12 Device and Documentation Support</b> .....	<b>22</b>
6.10 Supply Current Characteristics—5-V Supply .....	<b>8</b>	12.1 Documentation Support .....	<b>22</b>
6.11 Electrical Characteristics—3.3-V Supply .....	<b>9</b>	12.2 Related Links .....	<b>22</b>
6.12 Supply Current Characteristics—3.3-V Supply .....	<b>9</b>	12.3 Receiving Notification of Documentation Updates .....	<b>22</b>
6.13 Electrical Characteristics—2.5-V Supply .....	<b>10</b>	12.4 Community Resources .....	<b>22</b>
6.14 Supply Current Characteristics—2.5-V Supply .....	<b>10</b>	12.5 Trademarks .....	<b>22</b>
6.15 Switching Characteristics—5-V Supply .....	<b>11</b>	12.6 Electrostatic Discharge Caution .....	<b>22</b>
6.16 Switching Characteristics—3.3-V Supply .....	<b>11</b>	12.7 Glossary .....	<b>22</b>
6.17 Switching Characteristics—2.5-V Supply .....	<b>11</b>	<b>13 Mechanical, Packaging, and Orderable Information</b> .....	<b>23</b>
6.18 Insulation Characteristics Curves .....	<b>12</b>		

## 4 Revision History

NOTE: Page numbers for previous revisions may differ from page numbers in the current version.

DATE	REVISION	NOTES
March 2017	*	Initial release.

## 5 Pin Configuration and Functions

ISO7720-Q1 DW Package  
16-Pin SOIC  
Top View

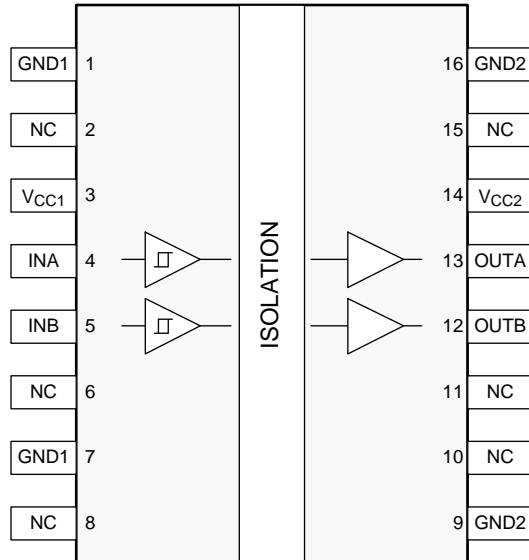

ISO7721-Q1 DW Package  
16-Pin SOIC  
Top View

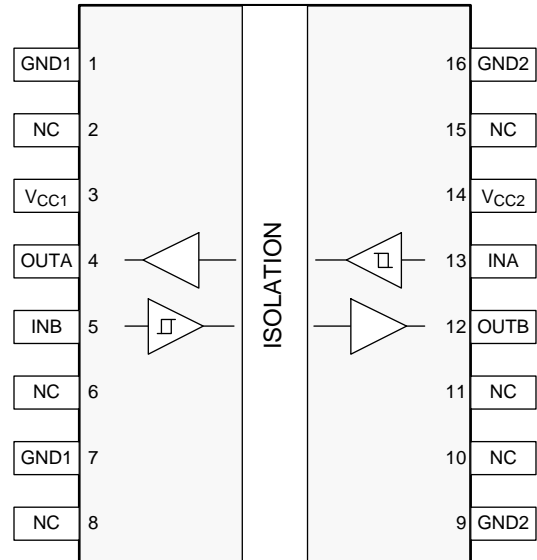

ISO7720-Q1 D Package  
8-Pin SOIC  
Top View

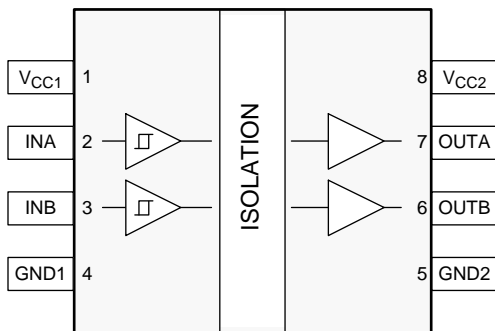

ISO7721-Q1 D Package  
8-Pin SOIC  
Top View

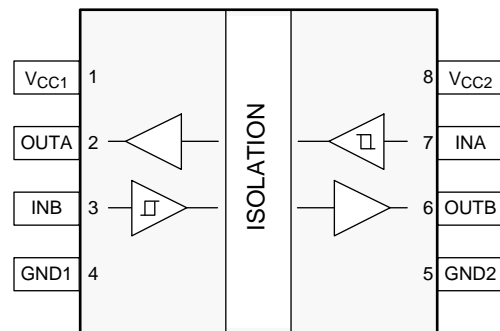

### Pin Functions

NAME	PIN				I/O	DESCRIPTION
	DW PACKAGE		D PACKAGE			
	ISO7720-Q1	ISO7721-Q1	ISO7720-Q1	ISO7721-Q1		
GND1	1, 7	1, 7	4	4	—	Ground connection for $V_{CC1}$
GND2	9	9	5	5	—	Ground connection for $V_{CC2}$
	16	16				
INA	4	13	2	7	I	Input, channel A
INB	5	5	3	3	I	Input, channel B
NC	2, 6, 8, 10, 11, 15	2, 6, 8, 10, 11, 15	—	—	—	Not connected
OUTA	13	4	7	2	O	Output, channel A
OUTB	12	12	6	6	O	Output, channel B
$V_{CC1}$	3	3	1	1	—	Power supply, $V_{CC1}$
$V_{CC2}$	14	14	8	8	—	Power supply, $V_{CC2}$

## 6 Specifications

### 6.1 Absolute Maximum Ratings

 See <sup>(1)</sup>.

		MIN	MAX	UNIT
$V_{CC1}, V_{CC2}$	Supply voltage <sup>(2)</sup>	-0.5	6	V
V	Voltage at INx, OUTx	-0.5	$V_{CC} + 0.5$ <sup>(3)</sup>	V
$I_O$	Output current	-15	15	mA
$T_J$	Junction temperature		150	°C
$T_{stg}$	Storage temperature	-65	150	°C

- (1) Stresses beyond those listed under *absolute maximum ratings* may cause permanent damage to the device. These are stress ratings only and functional operation of the device at these or any other conditions beyond those indicated under *Recommended Operating Conditions* is not implied. Exposure to absolute-maximum-rated conditions for extended periods may affect device reliability.
- (2) All voltage values except differential I/O bus voltages are with respect to the local ground terminal (GND1 or GND2) and are peak voltage values.
- (3) Maximum voltage must not exceed 6 V.

### 6.2 ESD Ratings

		VALUE	UNIT
$V_{(ESD)}$	Electrostatic discharge	Human-body model (HBM), per AEC Q100-002 <sup>(1)</sup>	±6000
		Charged-device model (CDM), per AEC Q100-011	±1500

- (1) AEC Q100-002 indicates that HBM stressing shall be in accordance with the ANSI/ESDA/JEDEC JS-001 specification.

### 6.3 Recommended Operating Conditions

		MIN	NOM	MAX	UNIT
$V_{CC1}, V_{CC2}$	Supply voltage	2.25		5.5	V
$V_{CC(UVLO+)}$	UVLO threshold when supply voltage is rising		2	2.25	V
$V_{CC(UVLO-)}$	UVLO threshold when supply voltage is falling	1.7	1.8		V
$V_{HYS(UVLO)}$	Supply voltage UVLO hysteresis	100	200		mV
$I_{OH}$	High-level output current	$V_{CCO}^{(1)} = 5\text{ V}$		-4	mA
		$V_{CCO} = 3.3\text{ V}$		-2	
		$V_{CCO} = 2.5\text{ V}$		-1	
$I_{OL}$	Low-level output current	$V_{CCO} = 5\text{ V}$		4	mA
		$V_{CCO} = 3.3\text{ V}$		2	
		$V_{CCO} = 2.5\text{ V}$		1	
$V_{IH}$	High-level input voltage	$0.7 \times V_{CCI}^{(1)}$		$V_{CCI}$	V
$V_{IL}$	Low-level input voltage	0		$0.3 \times V_{CCI}$	V
DR	Signaling rate	0		100	Mbps
$T_A$	Ambient temperature	-40	25	125	°C

- (1)  $V_{CCI}$  = Input-side  $V_{CC}$ ;  $V_{CCO}$  = Output-side  $V_{CC}$ .

## 6.4 Thermal Information

THERMAL METRIC <sup>(1)</sup>		ISO772x-Q1		UNIT
		DW (SOIC)	D (SOIC)	
		16 PINS	8 PINS	
R <sub>θJA</sub>	Junction-to-ambient thermal resistance	86.5	137.7	°C/W
R <sub>θJC(top)</sub>	Junction-to-case(top) thermal resistance	49.6	54.9	°C/W
R <sub>θJB</sub>	Junction-to-board thermal resistance	49.7	71.7	°C/W
ψ <sub>JT</sub>	Junction-to-top characterization parameter	32.3	7.1	°C/W
ψ <sub>JB</sub>	Junction-to-board characterization parameter	49.2	70.7	°C/W
R <sub>θJC(bottom)</sub>	Junction-to-case(bottom) thermal resistance	n/a	n/a	°C/W

(1) For more information about traditional and new thermal metrics, see the [Semiconductor and IC Package Thermal Metrics](#) application report.

## 6.5 Power Ratings

PARAMETER		TEST CONDITIONS	MIN	TYP	MAX	UNIT
<b>ISO7720-Q1</b>						
P <sub>D</sub>	Maximum power dissipation	V <sub>CC1</sub> = V <sub>CC2</sub> = 5.5 V, T <sub>J</sub> = 150°C, C <sub>L</sub> = 15 pF, input a 50 MHz 50% duty cycle square wave			100	mW
P <sub>D1</sub>	Maximum power dissipation by side-1	V <sub>CC1</sub> = V <sub>CC2</sub> = 5.5 V, T <sub>J</sub> = 150°C, C <sub>L</sub> = 15 pF, input a 50 MHz 50% duty cycle square wave			20	mW
P <sub>D2</sub>	Maximum power dissipation by side-2	V <sub>CC1</sub> = V <sub>CC2</sub> = 5.5 V, T <sub>J</sub> = 150°C, C <sub>L</sub> = 15 pF, input a 50 MHz 50% duty cycle square wave			80	mW
<b>ISO7721-Q1</b>						
P <sub>D</sub>	Maximum power dissipation	V <sub>CC1</sub> = V <sub>CC2</sub> = 5.5 V, T <sub>J</sub> = 150°C, C <sub>L</sub> = 15 pF, input a 50 MHz 50% duty cycle square wave			100	mW
P <sub>D1</sub>	Maximum power dissipation by side-1	V <sub>CC1</sub> = V <sub>CC2</sub> = 5.5 V, T <sub>J</sub> = 150°C, C <sub>L</sub> = 15 pF, input a 50 MHz 50% duty cycle square wave			50	mW
P <sub>D2</sub>	Maximum power dissipation by side-2	V <sub>CC1</sub> = V <sub>CC2</sub> = 5.5 V, T <sub>J</sub> = 150°C, C <sub>L</sub> = 15 pF, input a 50 MHz 50% duty cycle square wave			50	mW

## 6.6 Insulation Specifications

PARAMETER		TEST CONDITIONS	VALUE		UNIT
			DW-16	D-8	
CLR	External clearance <sup>(1)</sup>	Shortest terminal-to-terminal distance through air	8	4	mm
CPG	External creepage <sup>(1)</sup>	Shortest terminal-to-terminal distance across the package surface	8	4	mm
DTI	Distance through the insulation	Minimum internal gap (internal clearance)	21	21	μm
CTI	Comparative tracking index	DIN EN 60112 (VDE 0303-11); IEC 60112; UL 746A	>600	>600	V
	Material group	According to IEC 60664-1	I	I	
	Overvoltage category per IEC 60664-1	Rated mains voltage ≤ 150 V <sub>RMS</sub>	I-IV	I-IV	
		Rated mains voltage ≤ 300 V <sub>RMS</sub>	I-IV	I-III	
		Rated mains voltage ≤ 600 V <sub>RMS</sub>	I-IV	n/a	
		Rated mains voltage ≤ 1000 V <sub>RMS</sub>	I-III	n/a	
<b>DIN V VDE V 0884-10 (VDE V 0884-10):2006-12<sup>(2)</sup></b>					
V <sub>IORM</sub>	Maximum repetitive peak isolation voltage	AC voltage (bipolar)	1414	637	V <sub>PK</sub>
V <sub>IOWM</sub>	Maximum working isolation voltage	AC voltage; Time dependent dielectric breakdown (TDDB) test	1000	450	V <sub>RMS</sub>
		DC voltage	1414	637	V <sub>DC</sub>
V <sub>IOTM</sub>	Maximum transient isolation voltage	V <sub>TEST</sub> = V <sub>IOTM</sub> , t = 60 s (qualification); t = 1 s (100% production)	8000	4242	V <sub>PK</sub>
V <sub>IOSM</sub>	Maximum surge isolation voltage <sup>(3)</sup>	Test method per IEC 60065, 1.2/50 μs waveform, V <sub>TEST</sub> = 1.6 × V <sub>IOSM</sub> (qualification)	8000	5000	V <sub>PK</sub>
q <sub>pd</sub>	Apparent charge <sup>(4)</sup>	Method a, After Input/Output safety test subgroup 2/3, V <sub>ini</sub> = V <sub>IOTM</sub> , t <sub>ini</sub> = 60 s; V <sub>pd(m)</sub> = 1.2 × V <sub>IORM</sub> , t <sub>m</sub> = 10 s	≤5	≤5	pC
		Method a, After environmental tests subgroup 1, V <sub>ini</sub> = V <sub>IOTM</sub> , t <sub>ini</sub> = 60 s; V <sub>pd(m)</sub> = 1.6 × V <sub>IORM</sub> , t <sub>m</sub> = 10 s	≤5	≤5	
		Method b1; At routine test (100% production) and preconditioning (type test), V <sub>ini</sub> = V <sub>IOTM</sub> , t <sub>ini</sub> = 1 s; V <sub>pd(m)</sub> = 1.875 × V <sub>IORM</sub> , t <sub>m</sub> = 1 s	≤5	≤5	
C <sub>IO</sub>	Barrier capacitance, input to output <sup>(5)</sup>	V <sub>IO</sub> = 0.4 × sin (2πft), f = 1 MHz	~0.5	~0.5	pF
R <sub>IO</sub>	Isolation resistance <sup>(5)</sup>	V <sub>IO</sub> = 500 V, T <sub>A</sub> = 25°C	>10 <sup>12</sup>	>10 <sup>12</sup>	Ω
		V <sub>IO</sub> = 500 V, 100°C ≤ T <sub>A</sub> ≤ 125°C	>10 <sup>11</sup>	>10 <sup>11</sup>	
		V <sub>IO</sub> = 500 V at T <sub>S</sub> = 150°C	>10 <sup>9</sup>	>10 <sup>9</sup>	
	Pollution degree		2	2	
	Climatic category		55/125/21	5/125/21	
<b>UL 1577</b>					
V <sub>ISO</sub>	Withstanding isolation voltage	V <sub>TEST</sub> = V <sub>ISO</sub> , t = 60 s(qualification); V <sub>TEST</sub> = 1.2 × V <sub>ISO</sub> , t = 1 s (100% production)	5000	3000	V <sub>RMS</sub>

- (1) Creepage and clearance requirements should be applied according to the specific equipment isolation standards of an application. Care should be taken to maintain the creepage and clearance distance of a board design to ensure that the mounting pads of the isolator on the printed-circuit board do not reduce this distance. Creepage and clearance on a printed-circuit board become equal in certain cases. Techniques such as inserting grooves and/or ribs on a printed circuit board are used to help increase these specifications.
- (2) This coupler is suitable for *safe electrical insulation* only within the safety ratings. Compliance with the safety ratings shall be ensured by means of suitable protective circuits.
- (3) Testing is carried out in air or oil to determine the intrinsic surge immunity of the isolation barrier.
- (4) Apparent charge is electrical discharge caused by a partial discharge (pd).
- (5) All pins on each side of the barrier tied together creating a two-terminal device.

## 6.7 Safety-Related Certifications

DW package devices certified according to VDE, CSA, UL, and TUV; All other certifications are planned.

VDE	CSA	UL	CQC	TUV
Certified according to DIN V VDE V 0884-10 (VDE V 0884-10):2006-12	Certified under CSA Component Acceptance Notice 5A, IEC 60950-1, and IEC 60601-1	Certified according to UL 1577 Component Recognition Program	Plan to certify according to GB4943.1-2011	Certified according to EN 61010-1:2010 (3rd Ed) and EN 60950-1:2006/A11:2009/A1:2010/A12:2011/A2:2013
Maximum transient isolation voltage, 8000 V <sub>PK</sub> (DW-16, Reinforced) and 4242 V <sub>PK</sub> (D-8); Maximum repetitive peak isolation voltage, 1414 V <sub>PK</sub> (DW-16, Reinforced) and 637 V <sub>PK</sub> (D-8); Maximum surge isolation voltage, 8000 V <sub>PK</sub> (DW-16, Reinforced) and 5000 V <sub>PK</sub> (D-8)	Reinforced insulation per CSA 60950-1-07+A1+A2 and IEC 60950-1 2nd Ed., 800 V <sub>RMS</sub> (DW-16) and 400 V <sub>RMS</sub> (D-8) max working voltage (pollution degree 2, material group I);  2 MOPP (Means of Patient Protection) per CSA 60601-1:14 and IEC 60601-1 Ed. 3.1, 250 V <sub>RMS</sub> (DW-16) max working voltage	<b>DW-16:</b> Single protection, 5000 V <sub>RMS</sub> ; <b>D-8:</b> Single protection, 3000 V <sub>RMS</sub>	<b>DW-16:</b> Reinforced Insulation, Altitude ≤ 5000 m, Tropical Climate, 400 V <sub>RMS</sub> maximum working voltage; <b>D-8:</b> Basic Insulation, Altitude ≤ 5000 m, Tropical Climate, 250 V <sub>RMS</sub> maximum working voltage	5000 V <sub>RMS</sub> (DW-16) and 3000 V <sub>RMS</sub> (D-8) Reinforced insulation per EN 61010-1:2010 (3rd Ed) up to working voltage of 600 V <sub>RMS</sub> (DW-16) and 300 V <sub>RMS</sub> (D-8)  5000 V <sub>RMS</sub> (DW-16) and 3000 V <sub>RMS</sub> (D-8) Reinforced insulation per EN 60950-1:2006/A11:2009/A1:2010/A12:2011/A2:2013 up to working voltage of 800 V <sub>RMS</sub> (DW-16) and 400 V <sub>RMS</sub> (D-8)
Certificate number: 40040142	Master contract number: 220991	File number: E181974	Certification planned	Client ID number: 77311

## 6.8 Safety Limiting Values

Safety limiting intends to minimize potential damage to the isolation barrier upon failure of input or output circuitry. A failure of the I/O can allow low resistance to ground or the supply and, without current limiting, dissipate sufficient power to overheat the die and damage the isolation barrier potentially leading to secondary system failures.

PARAMETER		TEST CONDITIONS	MIN	TYP	MAX	UNIT
<b>DW-16 PACKAGE</b>						
I <sub>S</sub>	Safety input, output, or supply current	R <sub>θJA</sub> = 86.5 °C/W, V <sub>I</sub> = 5.5 V, T <sub>J</sub> = 150°C, T <sub>A</sub> = 25°C, see <a href="#">Figure 1</a>			263	mA
		R <sub>θJA</sub> = 86.5 °C/W, V <sub>I</sub> = 3.6 V, T <sub>J</sub> = 150°C, T <sub>A</sub> = 25°C, see <a href="#">Figure 1</a>			401	
		R <sub>θJA</sub> = 86.5 °C/W, V <sub>I</sub> = 2.75 V, T <sub>J</sub> = 150°C, T <sub>A</sub> = 25°C, see <a href="#">Figure 1</a>			525	
P <sub>S</sub>	Safety input, output, or total power	R <sub>θJA</sub> = 86.5 °C/W, T <sub>J</sub> = 150°C, T <sub>A</sub> = 25°C, see <a href="#">Figure 2</a>			1445	mW
T <sub>S</sub>	Maximum safety temperature				150	°C
<b>D-8 PACKAGE</b>						
I <sub>S</sub>	Safety input, output, or supply current	R <sub>θJA</sub> = 137.7 °C/W, V <sub>I</sub> = 5.5 V, T <sub>J</sub> = 150°C, T <sub>A</sub> = 25°C, see <a href="#">Figure 3</a>			165	mA
		R <sub>θJA</sub> = 137.7 °C/W, V <sub>I</sub> = 3.6 V, T <sub>J</sub> = 150°C, T <sub>A</sub> = 25°C, see <a href="#">Figure 3</a>			252	
		R <sub>θJA</sub> = 137.7 °C/W, V <sub>I</sub> = 2.75 V, T <sub>J</sub> = 150°C, T <sub>A</sub> = 25°C, see <a href="#">Figure 3</a>			330	
P <sub>S</sub>	Safety input, output, or total power	R <sub>θJA</sub> = 137.7 °C/W, T <sub>J</sub> = 150°C, T <sub>A</sub> = 25°C, see <a href="#">Figure 4</a>			908	mW
T <sub>S</sub>	Maximum safety temperature				150	°C

The maximum safety temperature is the maximum junction temperature specified for the device. The power dissipation and junction-to-air thermal impedance of the device installed in the application hardware determines the junction temperature. The assumed junction-to-air thermal resistance in the [Thermal Information](#) is that of a device installed on a high-K test board for leaded surface-mount packages. The power is the recommended maximum input voltage times the current. The junction temperature is then the ambient temperature plus the power times the junction-to-air thermal resistance.

## 6.9 Electrical Characteristics—5-V Supply

 $V_{CC1} = V_{CC2} = 5\text{ V} \pm 10\%$  (over recommended operating conditions unless otherwise noted)

PARAMETER	TEST CONDITIONS	MIN	TYP	MAX	UNIT
$V_{OH}$	High-level output voltage $I_{OH} = -4\text{ mA}$ ; see <a href="#">Figure 13</a>	$V_{CCO}^{(1)} - 0.4$	4.8		V
$V_{OL}$	Low-level output voltage $I_{OL} = 4\text{ mA}$ ; see <a href="#">Figure 13</a>		0.2	0.4	V
$V_{IT+(IN)}$	Rising input threshold voltage		$0.6 \times V_{CCI}$	$0.7 \times V_{CCI}$	V
$V_{IT-(IN)}$	Falling input threshold voltage	$0.3 \times V_{CCI}$	$0.4 \times V_{CCI}$		V
$V_{I(HYS)}$	Input threshold voltage hysteresis	$0.1 \times V_{CCI}$	$0.2 \times V_{CCI}$		V
$I_{IH}$	High-level input current $V_{IH} = V_{CCI}^{(1)}$ at INx			10	$\mu\text{A}$
$I_{IL}$	Low-level input current $V_{IL} = 0\text{ V}$ at INx	-10			$\mu\text{A}$
CMTI	Common-mode transient immunity $V_I = V_{CCI}$ or $0\text{ V}$ , $V_{CM} = 1200\text{ V}$ ; see <a href="#">Figure 15</a>	85	100		$\text{kV}/\mu\text{s}$
$C_I$	Input Capacitance <sup>(2)</sup> $V_I = V_{CC}/2 + 0.4 \times \sin(2\pi ft)$ , $f = 1\text{ MHz}$ , $V_{CC} = 5\text{ V}$		2		pF

 (1)  $V_{CCI}$  = Input-side  $V_{CC}$ ;  $V_{CCO}$  = Output-side  $V_{CC}$ .

(2) Measured from input pin to ground.

## 6.10 Supply Current Characteristics—5-V Supply

 $V_{CC1} = V_{CC2} = 5\text{ V} \pm 10\%$  (over recommended operating conditions unless otherwise noted)

PARAMETER	TEST CONDITIONS	SUPPLY CURRENT	MIN	TYP	MAX	UNIT	
<b>ISO7720-Q1</b>							
Supply current - DC signal	$V_I = V_{CCI}$ (ISO7720-Q1), $V_I = 0\text{ V}$ (ISO7720-Q1 with F suffix)	$I_{CC1}$		0.8	1.1	mA	
		$I_{CC2}$		1.1	1.7		
	$V_I = 0\text{ V}$ (ISO7720-Q1), $V_I = V_{CCI}$ (ISO7720-Q1 with F suffix)	$I_{CC1}$		2.9	4.2		
		$I_{CC2}$		1.2	1.9		
Supply current - AC signal	All channels switching with square wave clock input; $C_L = 15\text{ pF}$	1 Mbps	$I_{CC1}$		1.8		2.7
			$I_{CC2}$		1.3		1.9
		10 Mbps	$I_{CC1}$		1.9		2.7
			$I_{CC2}$		2.2		3
		100 Mbps	$I_{CC1}$		2.5	3.2	
			$I_{CC2}$		11.6	14	
<b>ISO7721-Q1</b>							
Supply current - DC signal	$V_I = V_{CCI}$ (ISO7721-Q1), $V_I = 0\text{ V}$ (ISO7721-Q1 with F suffix)	$I_{CC1}, I_{CC2}$		1	1.6	mA	
		$I_{CC1}, I_{CC2}$		2.2	3.2		
Supply current - AC signal	All channels switching with square wave clock input; $C_L = 15\text{ pF}$	1 Mbps	$I_{CC1}, I_{CC2}$		1.7		2.4
			$I_{CC1}, I_{CC2}$		2.2		3
		10 Mbps	$I_{CC1}, I_{CC2}$		2.2		3
			$I_{CC1}, I_{CC2}$		7.3		9

## 6.11 Electrical Characteristics—3.3-V Supply

 $V_{CC1} = V_{CC2} = 3.3 \text{ V} \pm 10\%$  (over recommended operating conditions unless otherwise noted)

PARAMETER		TEST CONDITIONS	MIN	TYP	MAX	UNIT
$V_{OH}$	High-level output voltage	$I_{OH} = -2 \text{ mA}$ ; see <a href="#">Figure 13</a>	$V_{CCO}^{(1)} - 0.3$	3.2		V
$V_{OL}$	Low-level output voltage	$I_{OL} = 2 \text{ mA}$ ; see <a href="#">Figure 13</a>		0.1	0.3	V
$V_{IT+(IN)}$	Rising input voltage threshold			$0.6 \times V_{CCI}$	$0.7 \times V_{CCI}$	V
$V_{IT-(IN)}$	Falling input voltage threshold		$0.3 \times V_{CCI}$	$0.4 \times V_{CCI}$		V
$V_{I(HYS)}$	Input threshold voltage hysteresis		$0.1 \times V_{CCI}$	$0.2 \times V_{CCI}$		V
$I_{IH}$	High-level input current	$V_{IH} = V_{CCI}^{(1)}$ at INx			10	$\mu\text{A}$
$I_{IL}$	Low-level input current	$V_{IL} = 0 \text{ V}$ at INx	-10			$\mu\text{A}$
CMTI	Common-mode transient immunity	$V_I = V_{CCI}$ or $0 \text{ V}$ , $V_{CM} = 1200 \text{ V}$ ; see <a href="#">Figure 15</a>	85	100		$\text{kV}/\mu\text{s}$

(1)  $V_{CCI}$  = Input-side  $V_{CC}$ ;  $V_{CCO}$  = Output-side  $V_{CC}$ .

## 6.12 Supply Current Characteristics—3.3-V Supply

 $V_{CC1} = V_{CC2} = 3.3 \text{ V} \pm 10\%$  (over recommended operating conditions unless otherwise noted)

PARAMETER	TEST CONDITIONS	SUPPLY CURRENT	MIN	TYP	MAX	UNIT
<b>ISO7720-Q1</b>						
Supply current - DC signal	$V_I = V_{CCI}$ (ISO7720-Q1), $V_I = 0 \text{ V}$ (ISO7720-Q1 with F suffix)	$I_{CC1}$		0.8	1.1	mA
		$I_{CC2}$		1.1	1.7	
	$V_I = 0 \text{ V}$ (ISO7720-Q1), $V_I = V_{CCI}$ (ISO7720-Q1 with F suffix)	$I_{CC1}$		2.9	4.2	
		$I_{CC2}$		1.2	1.9	
Supply current - AC signal	All channels switching with square wave clock input; $C_L = 15 \text{ pF}$	1 Mbps	$I_{CC1}$		1.8	2.7
			$I_{CC2}$		1.2	1.9
		10 Mbps	$I_{CC1}$		1.9	2.7
			$I_{CC2}$		1.9	2.6
		100 Mbps	$I_{CC1}$		2.2	3.1
			$I_{CC2}$		8.6	11
<b>ISO7721-Q1</b>						
Supply current - DC signal	$V_I = V_{CCI}$ (ISO7721-Q1), $V_I = 0 \text{ V}$ (ISO7721-Q1 with F suffix)	$I_{CC1}, I_{CC2}$		1	1.6	mA
		$I_{CC1}, I_{CC2}$		2.2	3.2	
Supply current - AC signal	All channels switching with square wave clock input; $C_L = 15 \text{ pF}$	1 Mbps	$I_{CC1}, I_{CC2}$		1.6	2.4
		10 Mbps	$I_{CC1}, I_{CC2}$		2	2.8
		100 Mbps	$I_{CC1}, I_{CC2}$		5.6	7

### 6.13 Electrical Characteristics—2.5-V Supply

 $V_{CC1} = V_{CC2} = 2.5 \text{ V} \pm 10\%$  (over recommended operating conditions unless otherwise noted)

PARAMETER		TEST CONDITIONS	MIN	TYP	MAX	UNIT
$V_{OH}$	High-level output voltage	$I_{OH} = -1 \text{ mA}$ ; see <a href="#">Figure 13</a>	$V_{CCO}^{(1)} - 0.2$	2.45		V
$V_{OL}$	Low-level output voltage	$I_{OL} = 1 \text{ mA}$ ; see <a href="#">Figure 13</a>		0.05	0.2	V
$V_{IT+(IN)}$	Rising input voltage threshold			$0.6 \times V_{CCI}$	$0.7 \times V_{CCI}$	V
$V_{IT-(IN)}$	Falling input voltage threshold		$0.3 \times V_{CCI}$	$0.4 \times V_{CCI}$		V
$V_{I(HYS)}$	Input threshold voltage hysteresis		$0.1 \times V_{CCI}$	$0.2 \times V_{CCI}$		V
$I_{IH}$	High-level input current	$V_{IH} = V_{CCI}^{(1)}$ at INx			10	$\mu\text{A}$
$I_{IL}$	Low-level input current	$V_{IL} = 0 \text{ V}$ at INx	-10			$\mu\text{A}$
CMTI	Common-mode transient immunity	$V_I = V_{CCI}$ or $0 \text{ V}$ , $V_{CM} = 1200 \text{ V}$ ; see <a href="#">Figure 15</a>	85	100		$\text{kV}/\mu\text{s}$

 (1)  $V_{CCI}$  = Input-side  $V_{CC}$ ;  $V_{CCO}$  = Output-side  $V_{CC}$ .

### 6.14 Supply Current Characteristics—2.5-V Supply

 $V_{CC1} = V_{CC2} = 2.5 \text{ V} \pm 10\%$  (over recommended operating conditions unless otherwise noted)

PARAMETER	TEST CONDITIONS	SUPPLY CURRENT	MIN	TYP	MAX	UNIT	
<b>ISO7720-Q1</b>							
Supply current - DC signal	$V_I = V_{CCI}$ (ISO7720-Q1), $V_I = 0 \text{ V}$ (ISO7720-Q1 with F suffix)	$I_{CC1}$		0.8	1.1	mA	
		$I_{CC2}$		1.1	1.7		
	$V_I = 0 \text{ V}$ (ISO7720-Q1), $V_I = V_{CCI}$ (ISO7720-Q1 with F suffix)	$I_{CC1}$		2.9	4.2		
		$I_{CC2}$		1.2	1.9		
Supply current - AC signal	All channels switching with square wave clock input; $C_L = 15 \text{ pF}$	1 Mbps	$I_{CC1}$		1.8		2.7
			$I_{CC2}$		1.3		1.9
		10 Mbps	$I_{CC1}$		1.9		2.7
			$I_{CC2}$		1.7		2.4
		100 Mbps	$I_{CC1}$		2.2	3	
			$I_{CC2}$		6.8	9	
<b>ISO7721-Q1</b>							
Supply current - DC signal	$V_I = V_{CCI}$ (ISO7721-Q1), $V_I = 0 \text{ V}$ (ISO7721-Q1 with F suffix)	$I_{CC1}, I_{CC2}$		1	1.6	mA	
		$I_{CC1}, I_{CC2}$		2.2	3.2		
Supply current - AC signal	All channels switching with square wave clock input; $C_L = 15 \text{ pF}$	1 Mbps	$I_{CC1}, I_{CC2}$		1.6		2.4
		10 Mbps	$I_{CC1}, I_{CC2}$		1.9		2.7
		100 Mbps	$I_{CC1}, I_{CC2}$		4.6		6

## 6.15 Switching Characteristics—5-V Supply

 $V_{CC1} = V_{CC2} = 5\text{ V} \pm 10\%$  (over recommended operating conditions unless otherwise noted)

PARAMETER	TEST CONDITIONS	MIN	TYP	MAX	UNIT
$t_{PLH}$ , $t_{PHL}$ Propagation delay time	See Figure 13	6	11	16	ns
PWD Pulse width distortion <sup>(1)</sup> $ t_{PHL} - t_{PLH} $			0.5	4.9	ns
$t_{sk(o)}$ Channel-to-channel output skew time <sup>(2)</sup>	Same direction channels			4	ns
$t_{sk(pp)}$ Part-to-part skew time <sup>(3)</sup>				4.5	ns
$t_r$ Output signal rise time	See Figure 13		1.8	3.9	ns
$t_f$ Output signal fall time				1.9	3.9
$t_{DO}$ Default output delay time from input power loss	Measured from the time $V_{CC}$ goes below 1.7 V. See Figure 14		0.1	0.3	$\mu$ s
$t_{ie}$ Time interval error	$2^{16} - 1$ PRBS data at 100 Mbps		1		ns

- (1) Also known as pulse skew.
- (2)  $t_{sk(o)}$  is the skew between outputs of a single device with all driving inputs connected together and the outputs switching in the same direction while driving identical loads.
- (3)  $t_{sk(pp)}$  is the magnitude of the difference in propagation delay times between any terminals of different devices switching in the same direction while operating at identical supply voltages, temperature, input signals and loads.

## 6.16 Switching Characteristics—3.3-V Supply

 $V_{CC1} = V_{CC2} = 3.3\text{ V} \pm 10\%$  (over recommended operating conditions unless otherwise noted)

PARAMETER	TEST CONDITIONS	MIN	TYP	MAX	UNIT
$t_{PLH}$ , $t_{PHL}$ Propagation delay time	See Figure 13	6	11	16	ns
PWD Pulse width distortion <sup>(1)</sup> $ t_{PHL} - t_{PLH} $				0.5	5
$t_{sk(o)}$ Channel-to-channel output skew time <sup>(2)</sup>	Same direction channels			4.1	ns
$t_{sk(pp)}$ Part-to-part skew time <sup>(3)</sup>				4.5	ns
$t_r$ Output signal rise time	See Figure 13		0.7	3	ns
$t_f$ Output signal fall time				0.7	3
$t_{DO}$ Default output delay time from input power loss	Measured from the time $V_{CC}$ goes below 1.7 V. See Figure 14		0.1	0.3	$\mu$ s
$t_{ie}$ Time interval error	$2^{16} - 1$ PRBS data at 100 Mbps		1		ns

- (1) Also known as pulse skew.
- (2)  $t_{sk(o)}$  is the skew between outputs of a single device with all driving inputs connected together and the outputs switching in the same direction while driving identical loads.
- (3)  $t_{sk(pp)}$  is the magnitude of the difference in propagation delay times between any terminals of different devices switching in the same direction while operating at identical supply voltages, temperature, input signals and loads.

## 6.17 Switching Characteristics—2.5-V Supply

 $V_{CC1} = V_{CC2} = 2.5\text{ V} \pm 10\%$  (over recommended operating conditions unless otherwise noted)

PARAMETER	TEST CONDITIONS	MIN	TYP	MAX	UNIT
$t_{PLH}$ , $t_{PHL}$ Propagation delay time	See Figure 13	7.5	12	18.5	ns
PWD Pulse width distortion <sup>(1)</sup> $ t_{PHL} - t_{PLH} $				0.5	5.1
$t_{sk(o)}$ Channel-to-channel output skew time <sup>(2)</sup>	Same direction channels			4.1	ns
$t_{sk(pp)}$ Part-to-part skew time <sup>(3)</sup>				4.6	ns
$t_r$ Output signal rise time	See Figure 13		1	3.5	ns
$t_f$ Output signal fall time				1	3.5
$t_{DO}$ Default output delay time from input power loss	Measured from the time $V_{CC}$ goes below 1.7 V. See Figure 14		0.1	0.3	$\mu$ s
$t_{ie}$ Time interval error	$2^{16} - 1$ PRBS data at 100 Mbps		1		ns

- (1) Also known as pulse skew.
- (2)  $t_{sk(o)}$  is the skew between outputs of a single device with all driving inputs connected together and the outputs switching in the same direction while driving identical loads.
- (3)  $t_{sk(pp)}$  is the magnitude of the difference in propagation delay times between any terminals of different devices switching in the same direction while operating at identical supply voltages, temperature, input signals and loads.

### 6.18 Insulation Characteristics Curves

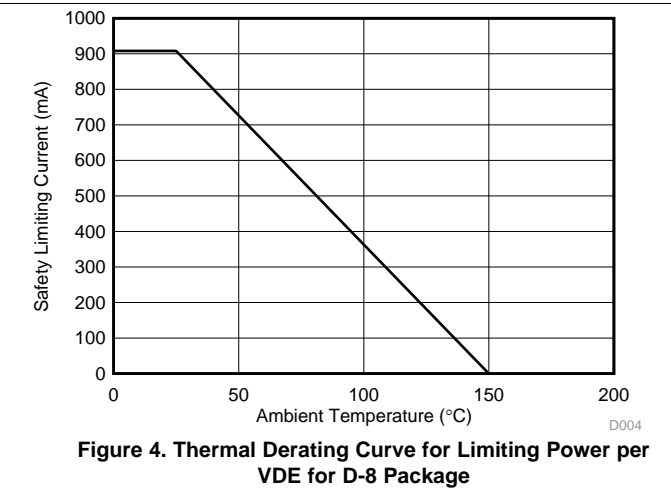
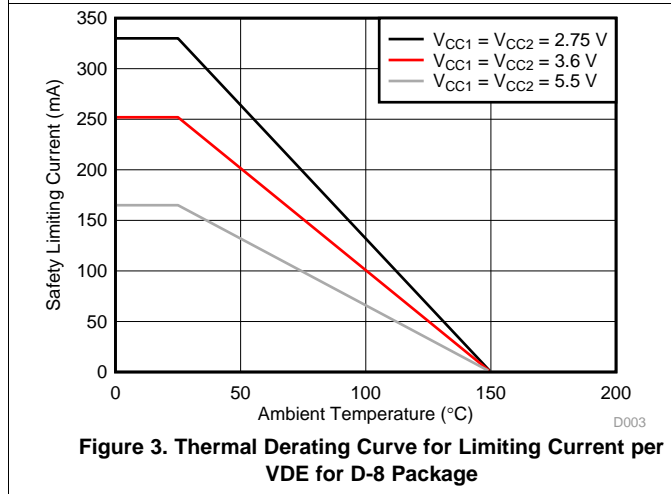
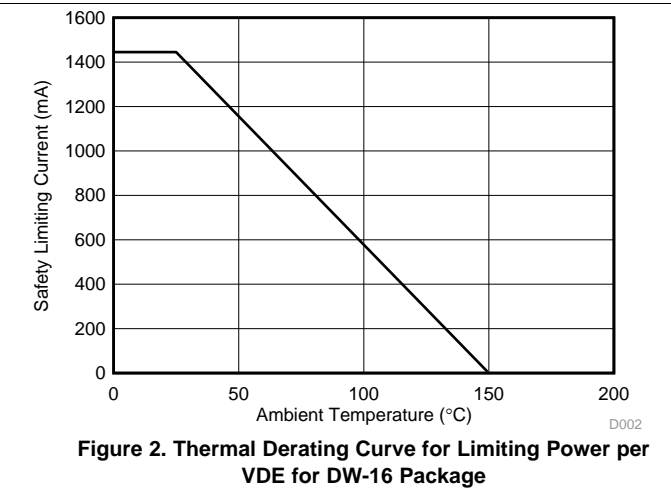
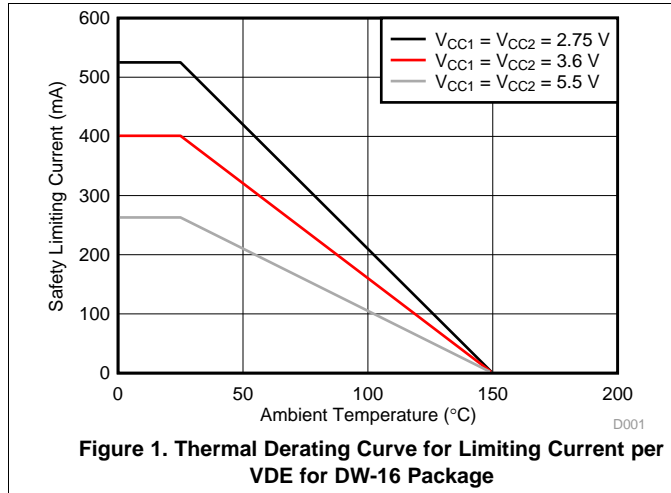

### 6.19 Typical Characteristics

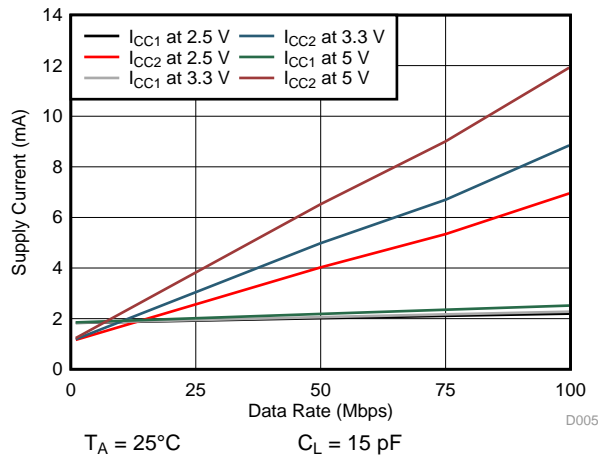

Figure 5. ISO7720-Q1 Supply Current vs Data Rate (With 15-pF Load)

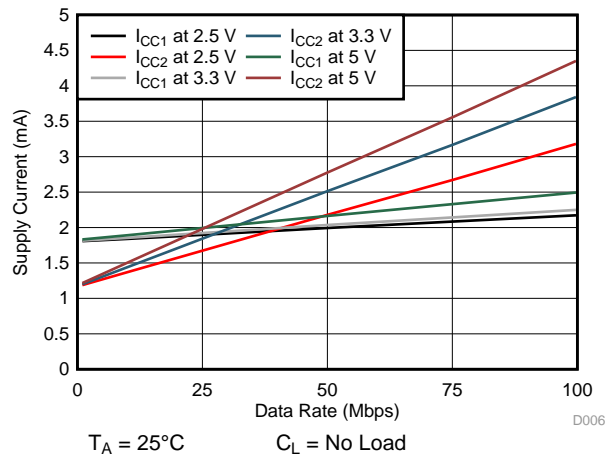

Figure 6. ISO7720-Q1 Supply Current vs Data Rate (With No Load)

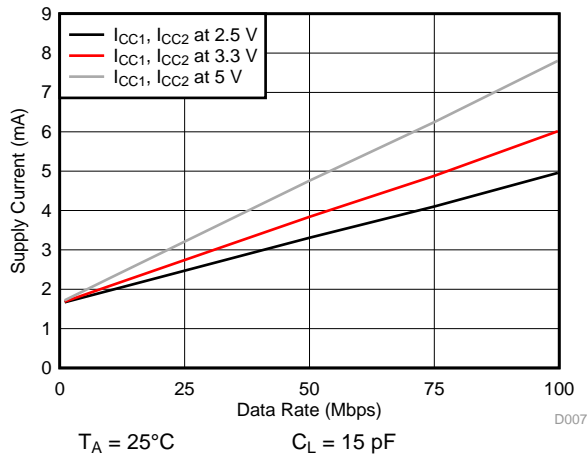

Figure 7. ISO7721-Q1 Supply Current vs Data Rate (With 15-pF Load)

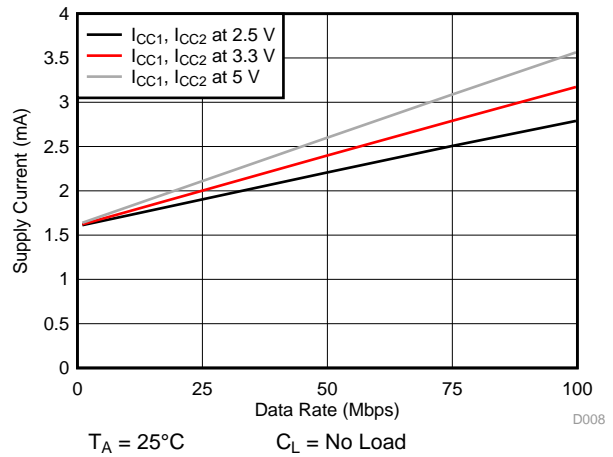

Figure 8. ISO7721-Q1 Supply Current vs Data Rate (With No Load)

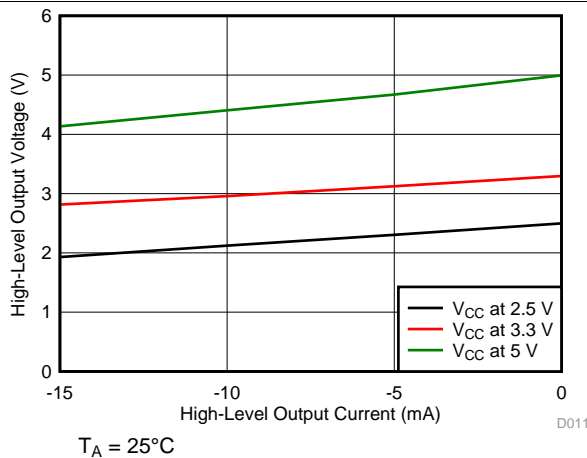

Figure 9. High-Level Output Voltage vs High-level Output Current

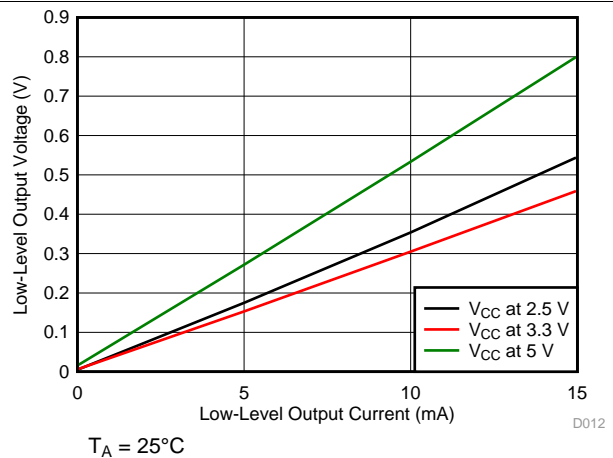
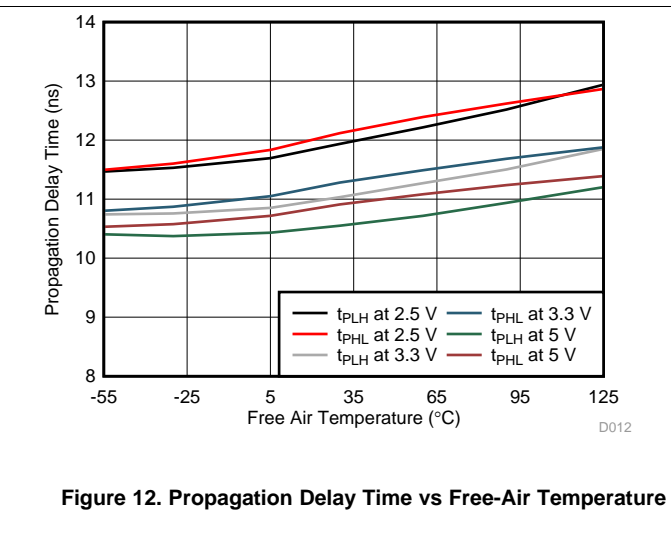
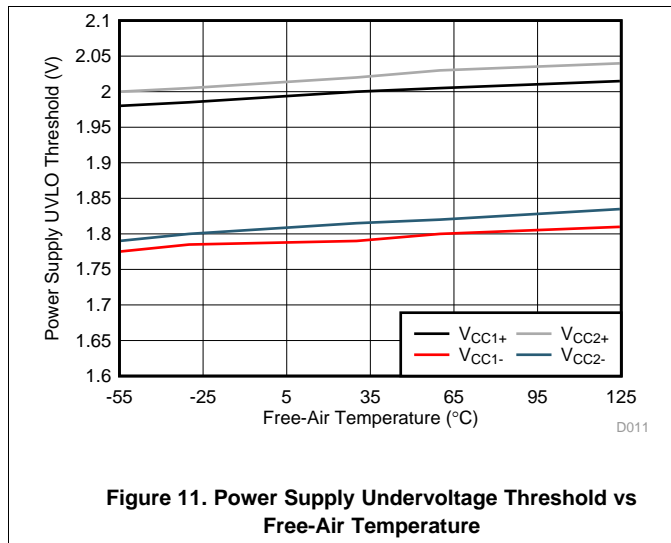
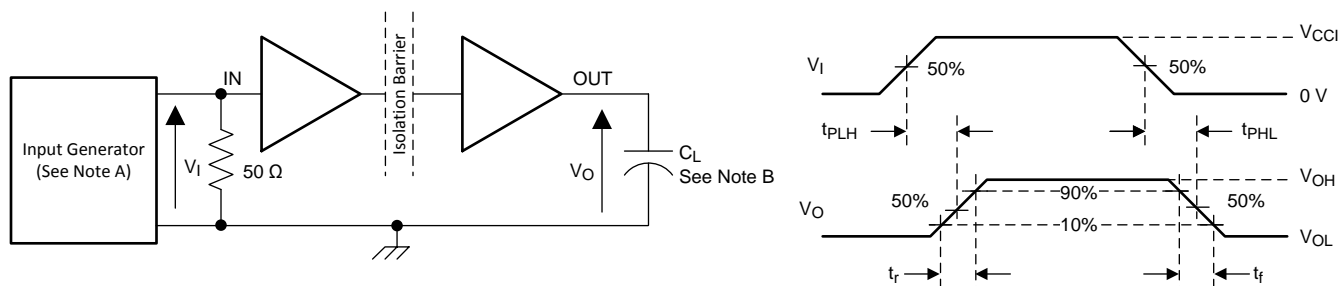

Figure 10. Low-Level Output Voltage vs Low-Level Output Current

**Typical Characteristics (continued)**



## 7 Parameter Measurement Information



- A. The input pulse is supplied by a generator having the following characteristics: PRR  $\leq$  50 kHz, 50% duty cycle,  $t_r \leq 3$  ns,  $t_f \leq 3$  ns,  $Z_O = 50 \Omega$ . At the input,  $50 \Omega$  resistor is required to terminate Input Generator signal. It is not needed in actual application.
- B.  $C_L = 15$  pF and includes instrumentation and fixture capacitance within  $\pm 20\%$ .

Figure 13. Switching Characteristics Test Circuit and Voltage Waveforms

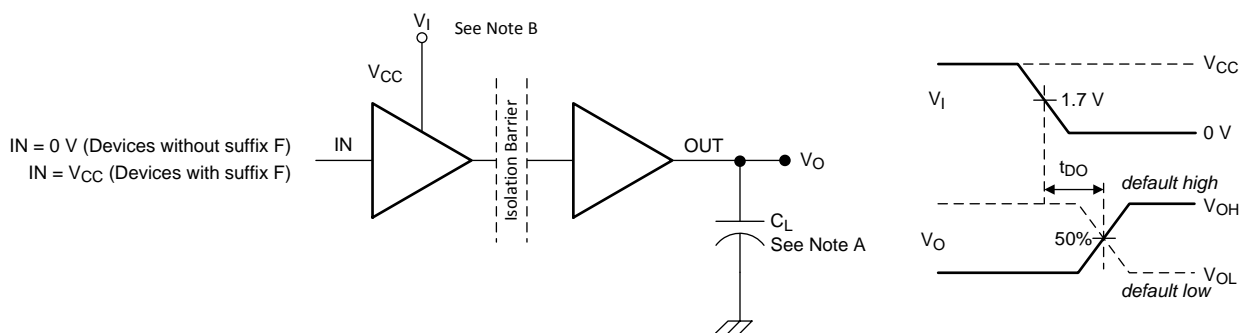

- A.  $C_L = 15$  pF and includes instrumentation and fixture capacitance within  $\pm 20\%$ .
- B. Power Supply Ramp Rate = 10 mV/ns

Figure 14. Default Output Delay Time Test Circuit and Voltage Waveforms

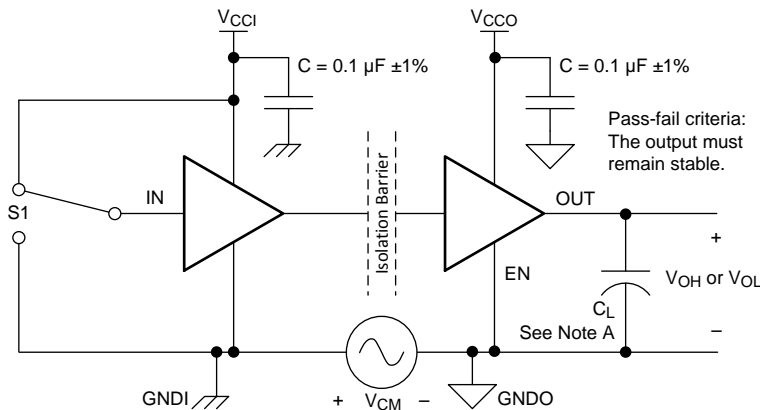

- A.  $C_L = 15$  pF and includes instrumentation and fixture capacitance within  $\pm 20\%$ .

Figure 15. Common-Mode Transient Immunity Test Circuit

## 8 Detailed Description

### 8.1 Overview

The ISO772x-Q1 family of devices has an ON-OFF keying (OOK) modulation scheme to transmit the digital data across a silicon dioxide based isolation barrier. The transmitter sends a high frequency carrier across the barrier to represent one digital state and sends no signal to represent the other digital state. The receiver demodulates the signal after advanced signal conditioning and produces the output through a buffer stage. These devices also incorporate advanced circuit techniques to maximize the CMTI performance and minimize the radiated emissions due to the high frequency carrier and IO buffer switching. The conceptual block diagram of a digital capacitive isolator, [Figure 16](#), shows a functional block diagram of a typical channel.

### 8.2 Functional Block Diagram

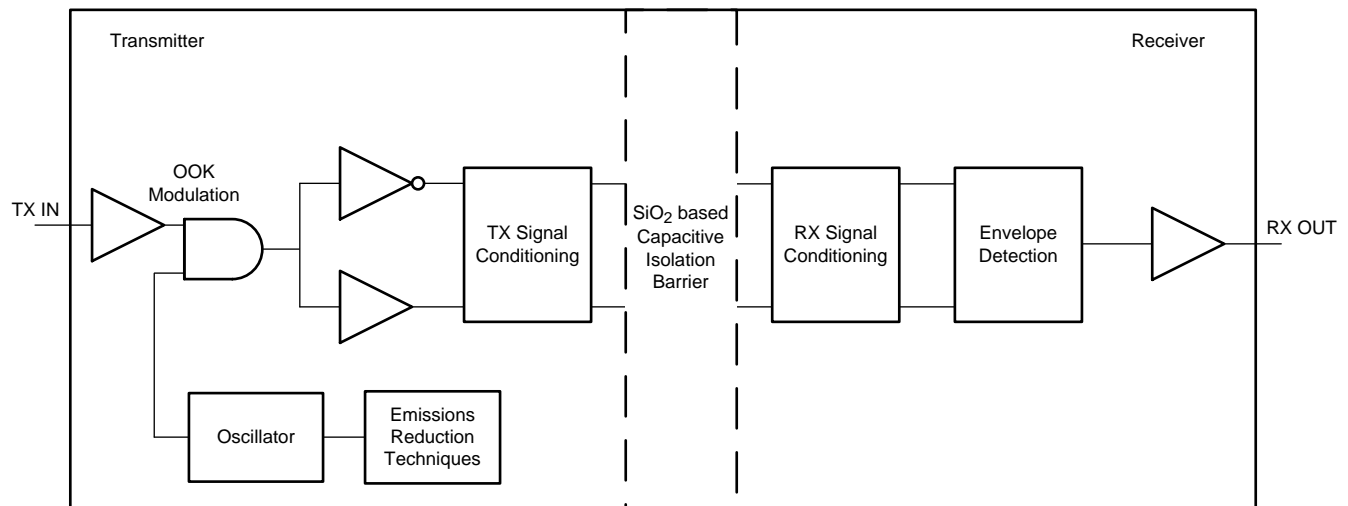

Copyright © 2017, Texas Instruments Incorporated

**Figure 16. Conceptual Block Diagram of a Digital Capacitive Isolator**

[Figure 17](#) shows a conceptual detail of how the OOK scheme works.

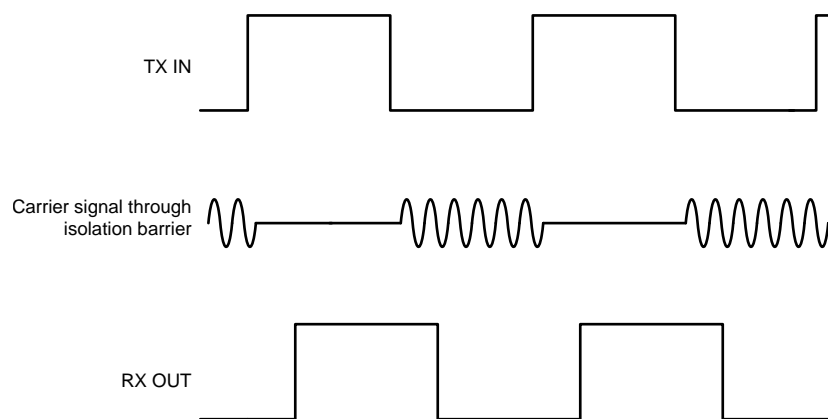

**Figure 17. On-Off Keying (OOK) Based Modulation Scheme**

### 8.3 Feature Description

The ISO772x-Q1 family of devices is available in two channel configurations and default output state options to enable a variety of application uses. [Table 1](#) lists the device features of the ISO772x-Q1 devices.

**Table 1. Device Features**

PART NUMBER	MAXIMUM DATA RATE	CHANNEL DIRECTION	DEFAULT OUTPUT STATE	PACKAGE	RATED ISOLATION <sup>(1)</sup>
ISO7720-Q1	100 Mbps	2 Forward, 0 Reverse	High	DW-16	5000 V <sub>RMS</sub> / 8000 V <sub>PK</sub>
				D-8	3000 V <sub>RMS</sub> / 4242 V <sub>PK</sub>
ISO7720-Q1 with F suffix	100 Mbps	2 Forward, 0 Reverse	Low	DW-16	5000 V <sub>RMS</sub> / 8000 V <sub>PK</sub>
				D-8	3000 V <sub>RMS</sub> / 4242 V <sub>PK</sub>
ISO7721-Q1	100 Mbps	1 Forward, 1 Reverse	High	DW-16	5000 V <sub>RMS</sub> / 8000 V <sub>PK</sub>
				D-8	3000 V <sub>RMS</sub> / 4242 V <sub>PK</sub>
ISO7721-Q1 with F suffix	100 Mbps	1 Forward, 1 Reverse	Low	DW-16	5000 V <sub>RMS</sub> / 8000 V <sub>PK</sub>
				D-8	3000 V <sub>RMS</sub> / 4242 V <sub>PK</sub>

(1) See the [Safety-Related Certifications](#) section for detailed isolation ratings.

#### 8.3.1 Electromagnetic Compatibility (EMC) Considerations

Many applications in harsh industrial environment are sensitive to disturbances such as electrostatic discharge (ESD), electrical fast transient (EFT), surge and electromagnetic emissions. These electromagnetic disturbances are regulated by international standards such as IEC 61000-4-x and CISPR 22. Although system-level performance and reliability depends, to a large extent, on the application board design and layout, the ISO772x-Q1 family of devices incorporates many chip-level design improvements for overall system robustness. Some of these improvements include:

- Robust ESD protection cells for input and output signal pins and inter-chip bond pads.
- Low-resistance connectivity of ESD cells to supply and ground pins.
- Enhanced performance of high voltage isolation capacitor for better tolerance of ESD, EFT and surge events.
- Bigger on-chip decoupling capacitors to bypass undesirable high energy signals through a low impedance path.
- PMOS and NMOS devices isolated from each other by using guard rings to avoid triggering of parasitic SCRs.
- Reduced common mode currents across the isolation barrier by ensuring purely differential internal operation.

### 8.4 Device Functional Modes

Table 2 lists the functional modes for the ISO772x-Q1 devices.

**Table 2. Function Table<sup>(1)</sup>**

V <sub>CCI</sub>	V <sub>CCO</sub>	INPUT (IN <sub>x</sub> ) <sup>(2)</sup>	OUTPUT (OUT <sub>x</sub> )	COMMENTS
PU	PU	H	H	Normal Operation: A channel output assumes the logic state of the input.
		L	L	
		Open	Default	Default mode: When IN <sub>x</sub> is open, the corresponding channel output goes to the default high logic state. The default is <i>High</i> for ISO772x-Q1 and <i>Low</i> for ISO772x-Q1 with F suffix.
PD	PU	X	Default	Default mode: When V <sub>CCI</sub> is unpowered, a channel output assumes the logic state based on the selected default option. The default is <i>High</i> for ISO772x-Q1 and <i>Low</i> for ISO772x-Q1 with F suffix. When V <sub>CCI</sub> transitions from unpowered to powered-up, a channel output assumes the logic state of the input. When V <sub>CCI</sub> transitions from powered-up to unpowered, channel output assumes the selected default state.
X	PD	X	Undetermined	When V <sub>CCO</sub> is unpowered, a channel output is undetermined <sup>(3)</sup> . When V <sub>CCO</sub> transitions from unpowered to powered-up, a channel output assumes the logic state of the input

- (1) V<sub>CCI</sub> = Input-side V<sub>CC</sub>; V<sub>CCO</sub> = Output-side V<sub>CC</sub>; PU = Powered up (V<sub>CC</sub> ≥ 2.25 V); PD = Powered down (V<sub>CC</sub> ≤ 1.7 V); X = Irrelevant; H = High level; L = Low level
- (2) A strongly driven input signal can weakly power the floating V<sub>CC</sub> via an internal protection diode and cause undetermined output.
- (3) The outputs are in undetermined state when 1.7 V < V<sub>CCI</sub>, V<sub>CCO</sub> < 2.25 V.

#### 8.4.1 Device I/O Schematics

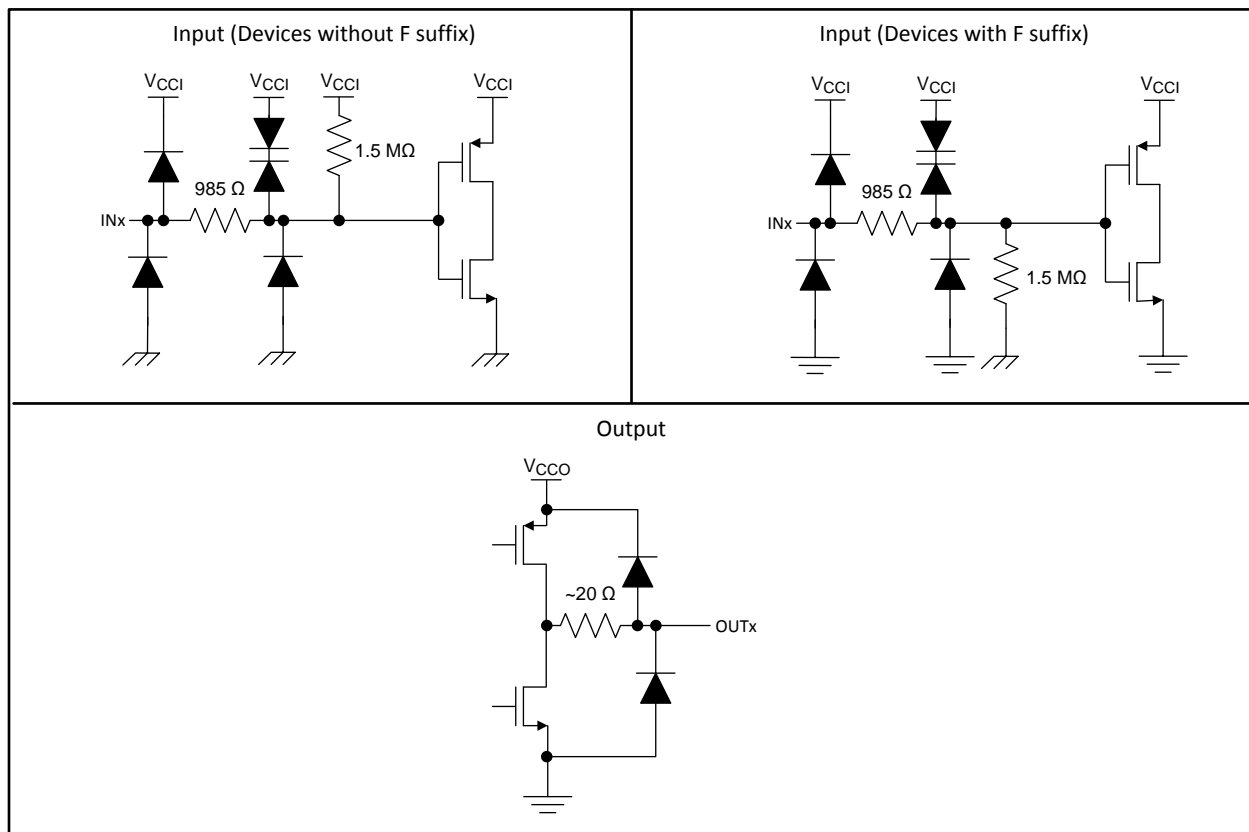

**Figure 18. Device I/O Schematics**

## 9 Applications and Implementation

### NOTE

Information in the following applications sections is not part of the TI component specification, and TI does not warrant the accuracy or completeness. TI's customers are responsible for determining suitability of components for their purposes. Customers should validate and test their design implementation to confirm system functionality.

### 9.1 Application Information

The ISO772x-Q1 devices are high-performance, dual-channel digital isolators. The devices use single-ended CMOS-logic switching technology. The supply voltage range is from 2.25 V to 5.5 V for both supplies,  $V_{CC1}$  and  $V_{CC2}$ . When designing with digital isolators, keep in mind that because of the single-ended design structure, digital isolators do not conform to any specific interface standard and are only intended for isolating single-ended CMOS or TTL digital signal lines. The isolator is typically placed between the data controller (that is,  $\mu C$  or UART), and a data converter or a line transceiver, regardless of the interface type or standard.

### 9.2 Typical Application

The ISO7721-Q1 device can be used with Texas Instruments' Piccolo™ microcontroller, CAN transceiver, transformer driver, and voltage regulator to create an isolated CAN interface.

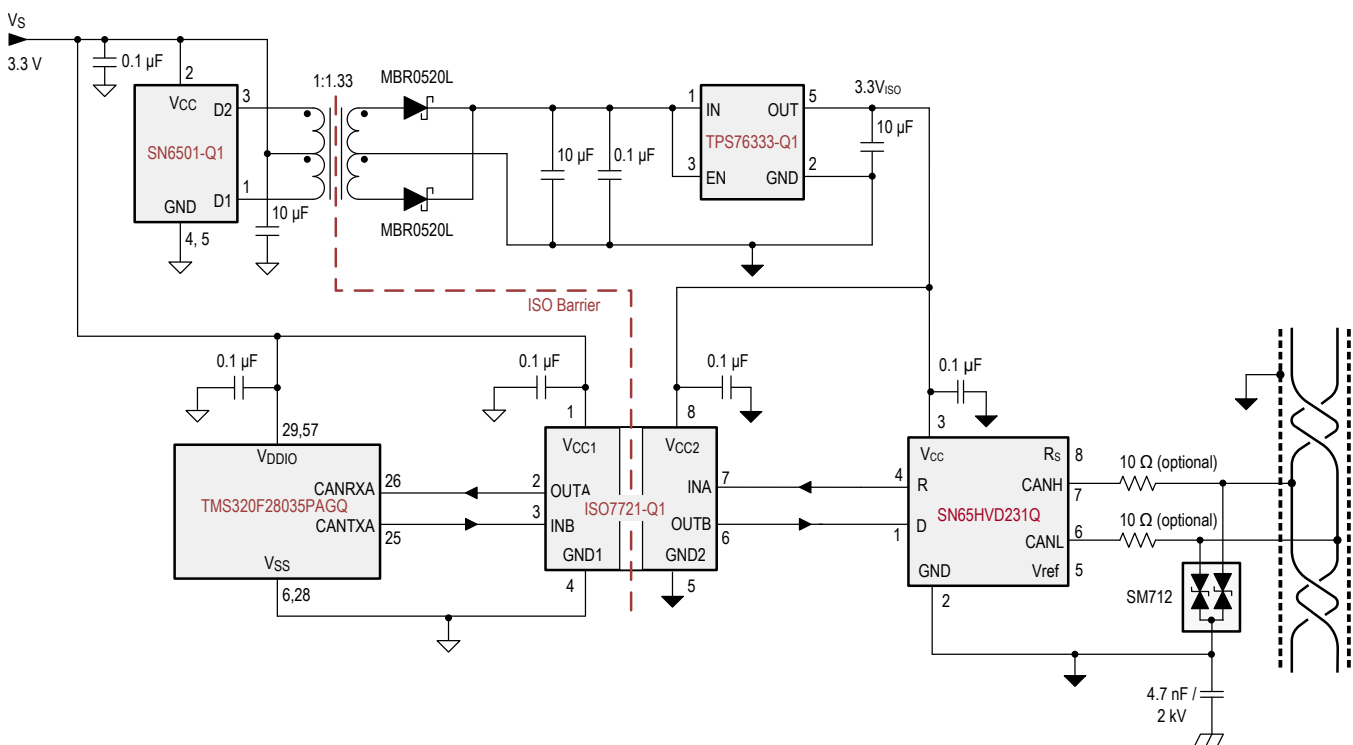

Copyright © 2017, Texas Instruments Incorporated

Figure 19. Isolated 4-mA to 20-mA Current Loop

## Typical Application (continued)

### 9.2.1 Design Requirements

To design with these devices, use the parameters listed in [Table 3](#).

**Table 3. Design Parameters**

PARAMETER	VALUE
Supply voltage, $V_{CC1}$ and $V_{CC2}$	2.25 V to 5.5 V
Decoupling capacitor between $V_{CC1}$ and GND1	0.1 $\mu$ F
Decoupling capacitor from $V_{CC2}$ and GND2	0.1 $\mu$ F

### 9.2.2 Detailed Design Procedure

Unlike optocouplers, which require external components to improve performance, provide bias, or limit current, the ISO772x-Q1 devices only require two external bypass capacitors to operate.

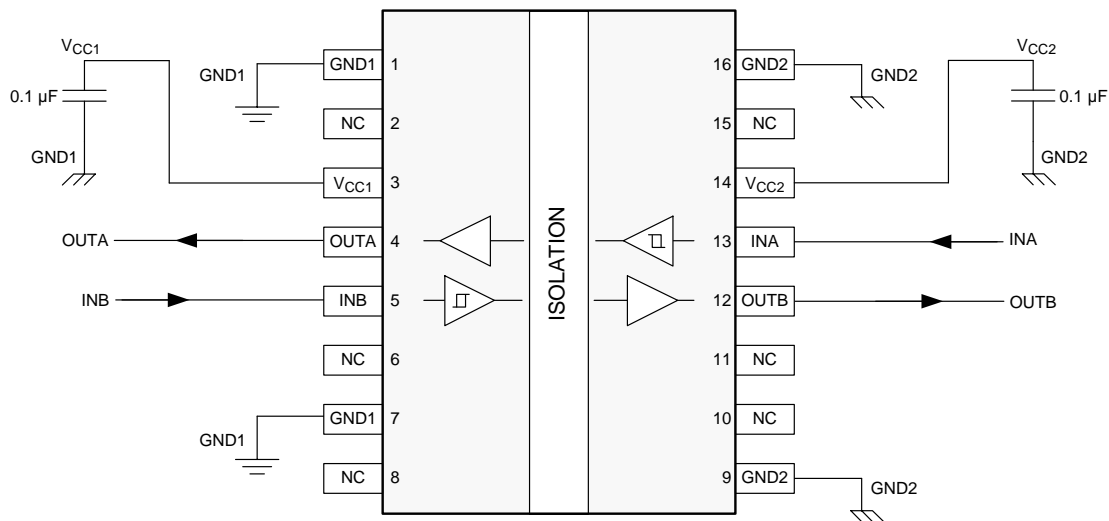

**Figure 20. Typical ISO7721-Q1 Circuit Hook-up**

### 9.2.3 Application Curve

The following typical eye diagrams of the ISO772x-Q1 family of devices indicate low jitter and wide open eye at the maximum data rate of 100 Mbps.

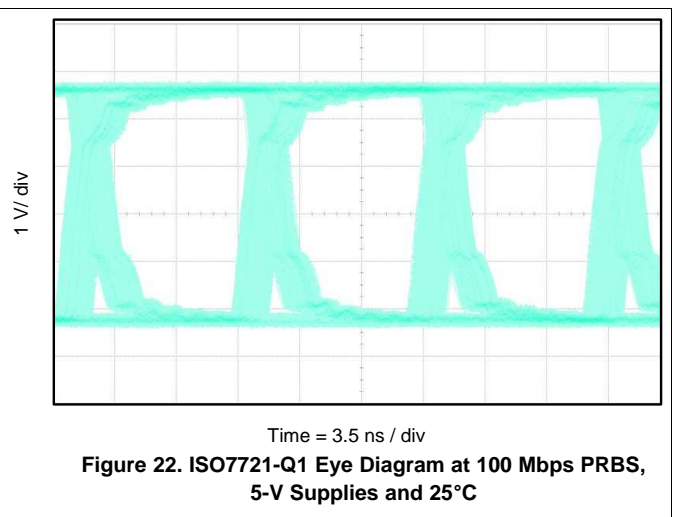
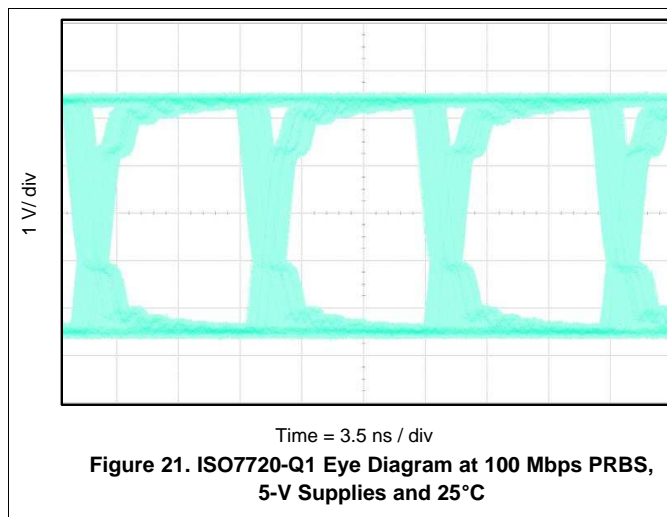

## 10 Power Supply Recommendations

To help ensure reliable operation at data rates and supply voltages, a 0.1- $\mu$ F bypass capacitor is recommended at the input and output supply pins ( $V_{CC1}$  and  $V_{CC2}$ ). The capacitors should be placed as close to the supply pins as possible. If only a single primary-side power supply is available in an application, isolated power can be generated for the secondary-side with the help of a transformer driver such as Texas Instruments' [SN6501-Q1](#). For such applications, detailed power supply design and transformer selection recommendations are available in [SN6501-Q1 Transformer Driver for Isolated Power Supplies](#).

## 11 Layout

### 11.1 Layout Guidelines

A minimum of four layers is required to accomplish a low EMI PCB design (see [Figure 23](#)). Layer stacking should be in the following order (top-to-bottom): high-speed signal layer, ground plane, power plane and low-frequency signal layer.

- Routing the high-speed traces on the top layer avoids the use of vias (and the introduction of their inductances) and allows for clean interconnects between the isolator and the transmitter and receiver circuits of the data link.
- Placing a solid ground plane next to the high-speed signal layer establishes controlled impedance for transmission line interconnects and provides an excellent low-inductance path for the return current flow.
- Placing the power plane next to the ground plane creates additional high-frequency bypass capacitance of approximately 100 pF/in<sup>2</sup>.
- Routing the slower speed control signals on the bottom layer allows for greater flexibility as these signal links usually have margin to tolerate discontinuities such as vias.

If an additional supply voltage plane or signal layer is needed, add a second power or ground plane system to the stack to keep it symmetrical. This makes the stack mechanically stable and prevents it from warping. Also the power and ground plane of each power system can be placed closer together, thus increasing the high-frequency bypass capacitance significantly.

For detailed layout recommendations, refer to the [Digital Isolator Design Guide](#).

#### 11.1.1 PCB Material

For digital circuit boards operating at less than 150 Mbps, (or rise and fall times greater than 1 ns), and trace lengths of up to 10 inches, use standard FR-4 UL94V-0 printed circuit board. This PCB is preferred over cheaper alternatives because of lower dielectric losses at high frequencies, less moisture absorption, greater strength and stiffness, and the self-extinguishing flammability-characteristics.

### 11.2 Layout Example

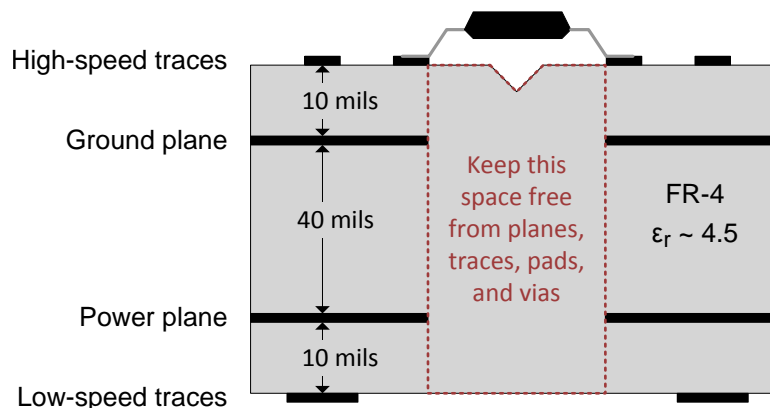

**Figure 23. Layout Example**

## 12 Device and Documentation Support

### 12.1 Documentation Support

#### 12.1.1 Related Documentation

For related documentation, see the following:

- [Digital Isolator Design Guide](#)
- [Isolation Glossary](#)
- [SN6501-Q1 Transformer Driver for Isolated Power Supplies](#)
- [SN65HVD231Q 3.3-V CAN Transceivers](#)
- [TPS763xx-Q1 Low-Power, 150-mA, Low-Dropout Linear Regulators](#)
- [TMS320F2803x Piccolo™ Microcontrollers](#)

### 12.2 Related Links

The table below lists quick access links. Categories include technical documents, support and community resources, tools and software, and quick access to sample or buy.

**Table 4. Related Links**

PARTS	PRODUCT FOLDER	ORDER NOW	TECHNICAL DOCUMENTS	TOOLS & SOFTWARE	SUPPORT & COMMUNITY
ISO7720-Q1	<a href="#">Click here</a>	<a href="#">Click here</a>	<a href="#">Click here</a>	<a href="#">Click here</a>	<a href="#">Click here</a>
ISO7721-Q1	<a href="#">Click here</a>	<a href="#">Click here</a>	<a href="#">Click here</a>	<a href="#">Click here</a>	<a href="#">Click here</a>

### 12.3 Receiving Notification of Documentation Updates

To receive notification of documentation updates, navigate to the device product folder on ti.com. In the upper right corner, click on *Alert me* to register and receive a weekly digest of any product information that has changed. For change details, review the revision history included in any revised document.

### 12.4 Community Resources

The following links connect to TI community resources. Linked contents are provided "AS IS" by the respective contributors. They do not constitute TI specifications and do not necessarily reflect TI's views; see TI's [Terms of Use](#).

**TI E2E™ Online Community** *TI's Engineer-to-Engineer (E2E) Community*. Created to foster collaboration among engineers. At [e2e.ti.com](http://e2e.ti.com), you can ask questions, share knowledge, explore ideas and help solve problems with fellow engineers.

**Design Support** *TI's Design Support* Quickly find helpful E2E forums along with design support tools and contact information for technical support.

### 12.5 Trademarks

Piccolo, E2E are trademarks of Texas Instruments.  
All other trademarks are the property of their respective owners.

### 12.6 Electrostatic Discharge Caution



This integrated circuit can be damaged by ESD. Texas Instruments recommends that all integrated circuits be handled with appropriate precautions. Failure to observe proper handling and installation procedures can cause damage.

ESD damage can range from subtle performance degradation to complete device failure. Precision integrated circuits may be more susceptible to damage because very small parametric changes could cause the device not to meet its published specifications.

### 12.7 Glossary

**SLYZ022** — *TI Glossary*.

This glossary lists and explains terms, acronyms, and definitions.

### 13 Mechanical, Packaging, and Orderable Information

The following pages include mechanical packaging and orderable information. This information is the most current data available for the designated devices. This data is subject to change without notice and revision of this document. For browser-based versions of this data sheet, refer to the left-hand navigation.

**D0008B**
**PACKAGE OUTLINE**
**SOIC - 1.75 mm max height**

SOIC

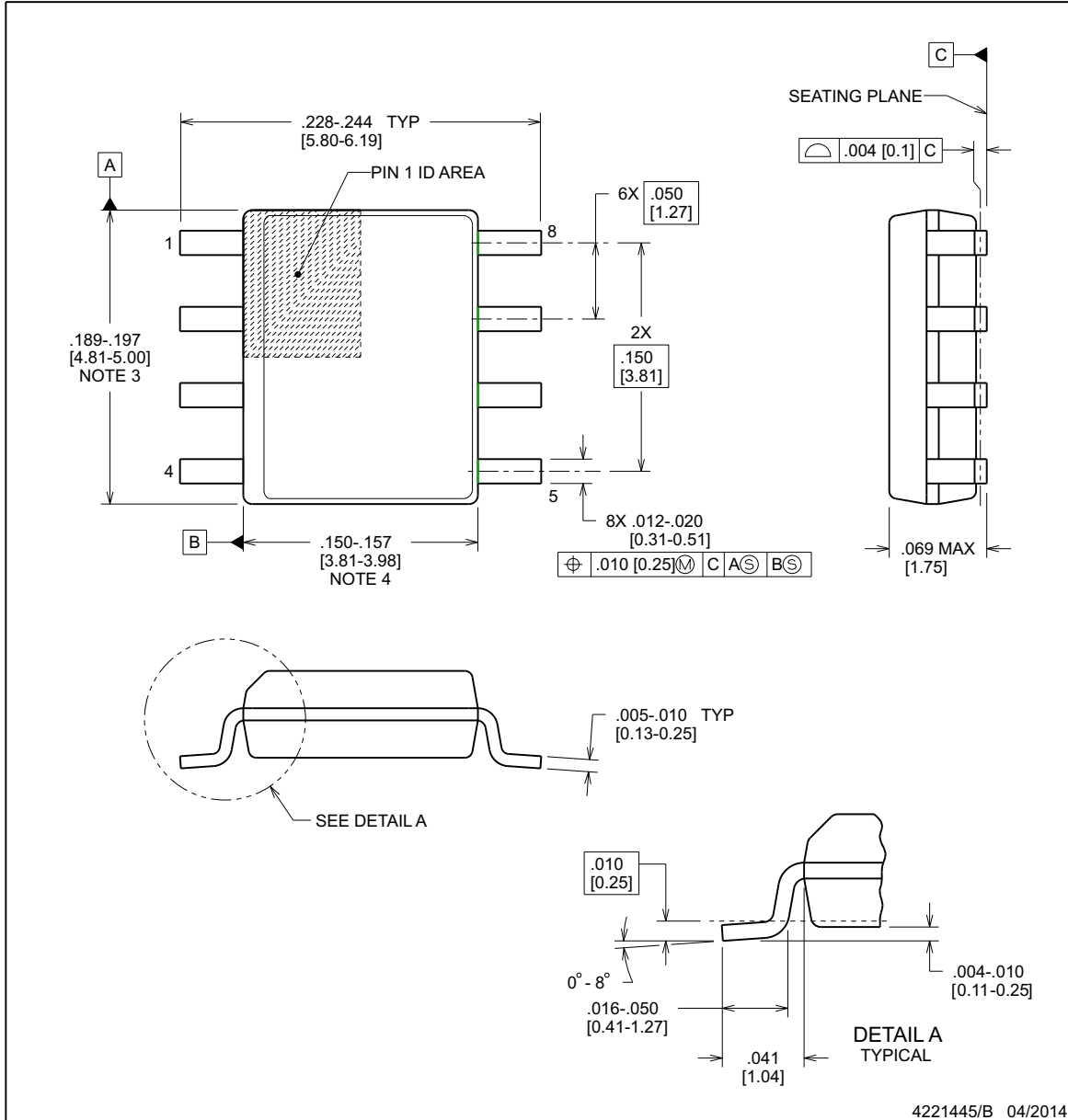

4221445/B 04/2014

**NOTES:**

- Linear dimensions are in inches [millimeters]. Dimensions in parenthesis are for reference only. Controlling dimensions are in inches. Dimensioning and tolerancing per ASME Y14.5M.
- This drawing is subject to change without notice.
- This dimension does not include mold flash, protrusions, or gate burrs. Mold flash, protrusions, or gate burrs shall not exceed  $.006$  [0.15], per side.
- This dimension does not include interlead flash.
- Reference JEDEC registration MS-012, variation AA.

**EXAMPLE BOARD LAYOUT**

**D0008B**

**SOIC - 1.75 mm max height**

SOIC

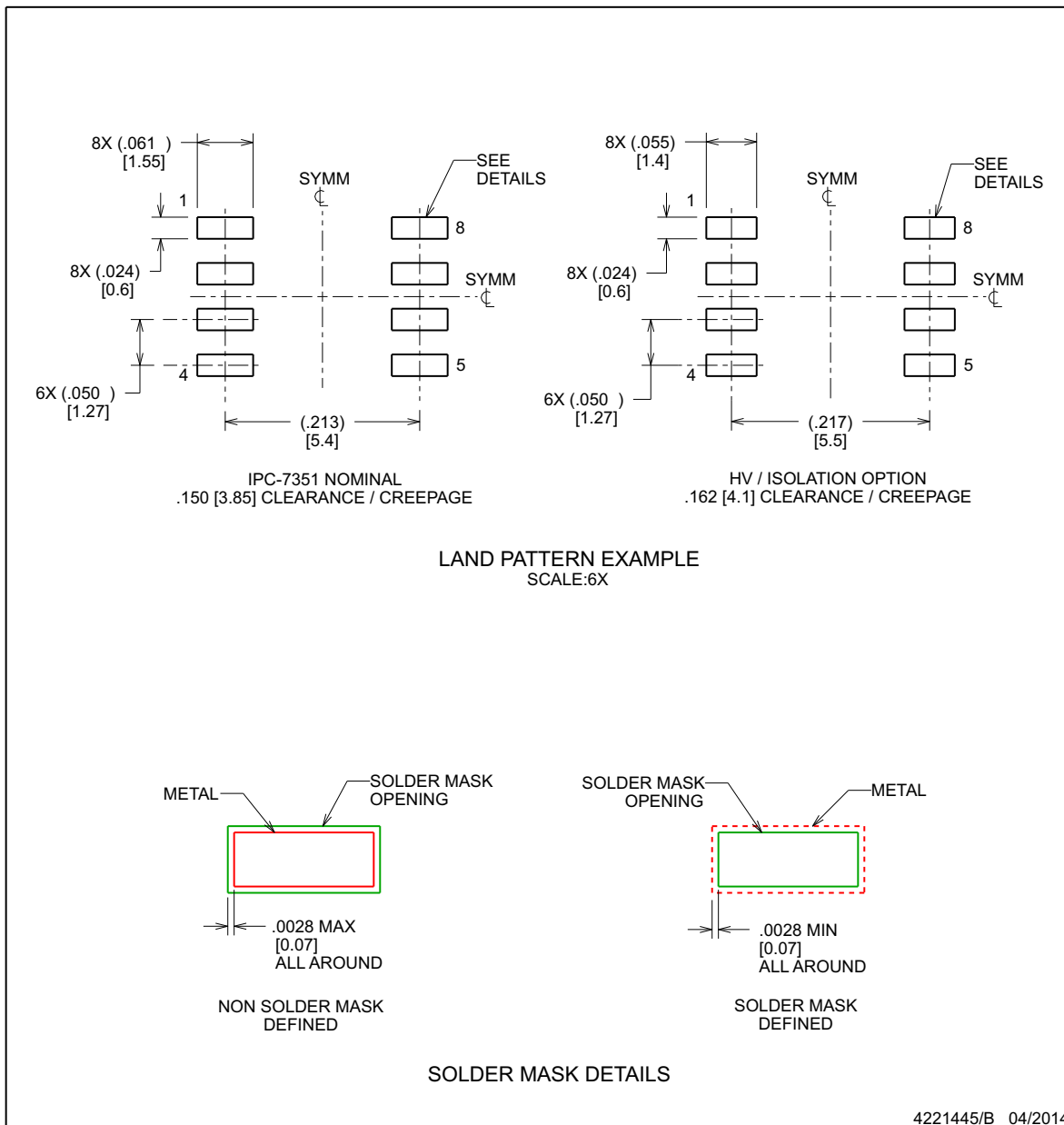

NOTES: (continued)

- 6. Publication IPC-7351 may have alternate designs.
- 7. Solder mask tolerances between and around signal pads can vary based on board fabrication site.

## EXAMPLE STENCIL DESIGN

**D0008B**
**SOIC - 1.75 mm max height**

SOIC

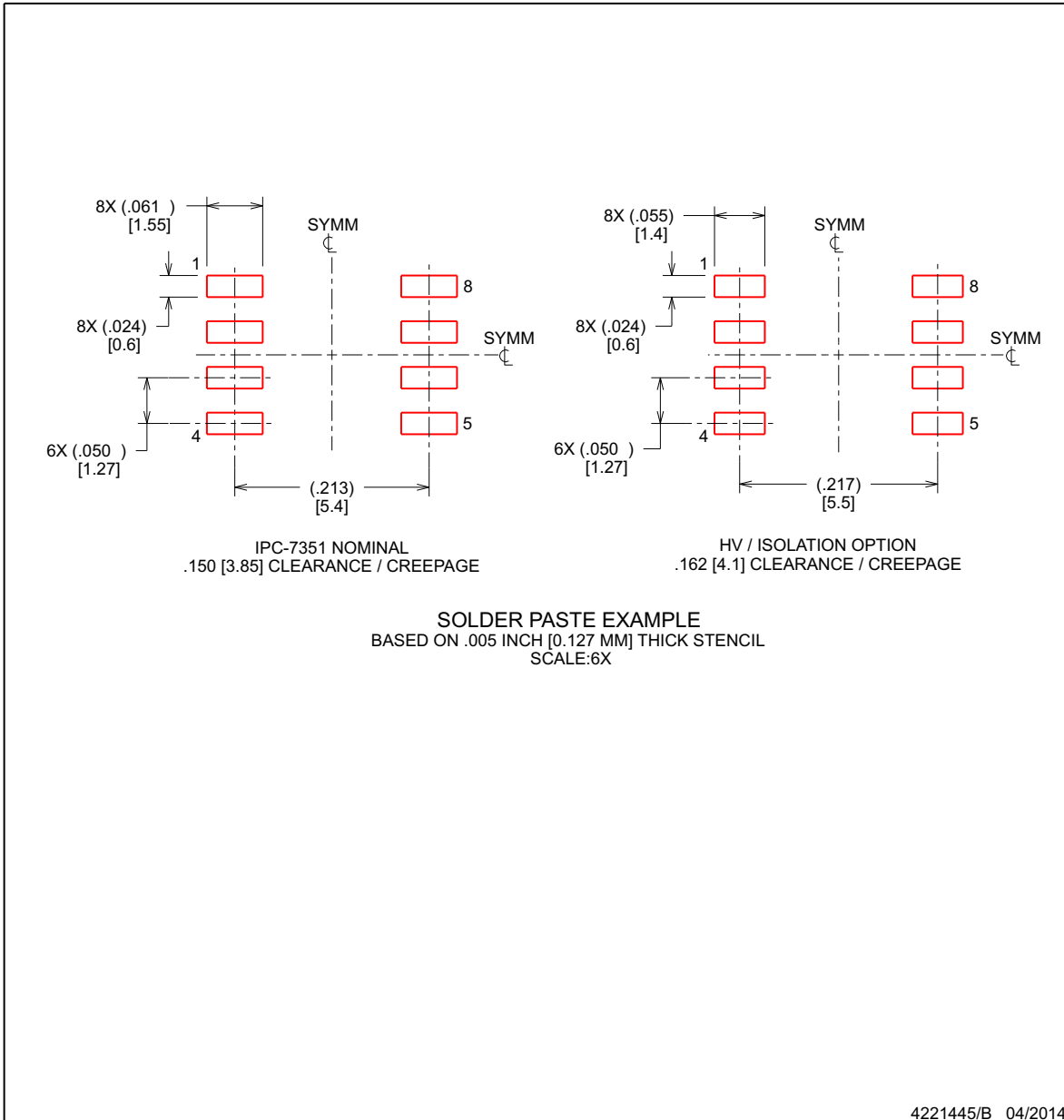

NOTES: (continued)

8. Laser cutting apertures with trapezoidal walls and rounded corners may offer better paste release. IPC-7525 may have alternate design recommendations.
9. Board assembly site may have different recommendations for stencil design.



**DW0016B**

**PACKAGE OUTLINE**

**SOIC - 2.65 mm max height**

SOIC

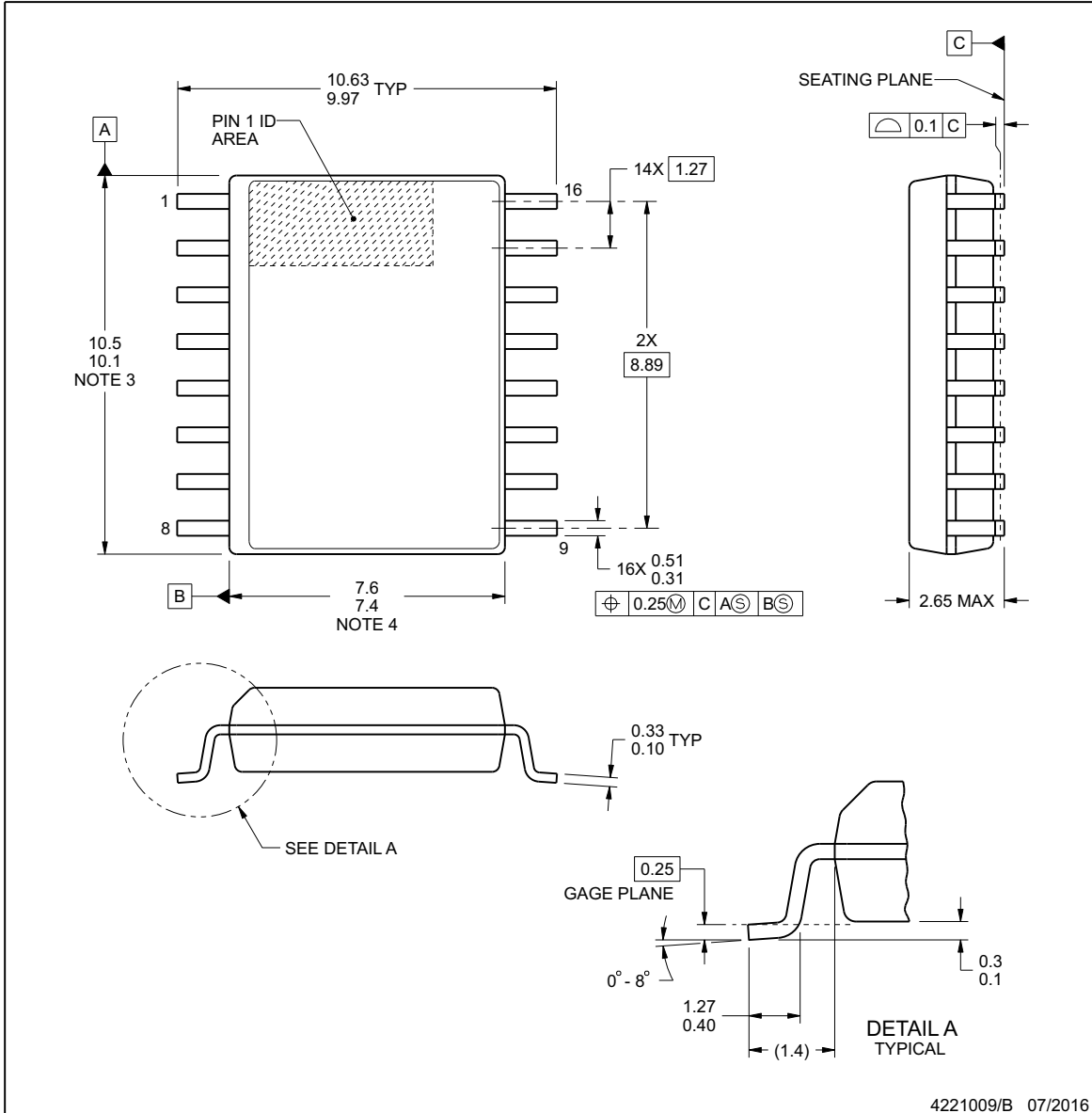

4221009/B 07/2016

**NOTES:**

1. All linear dimensions are in millimeters. Dimensions in parenthesis are for reference only. Dimensioning and tolerancing per ASME Y14.5M.
2. This drawing is subject to change without notice.
3. This dimension does not include mold flash, protrusions, or gate burrs. Mold flash, protrusions, or gate burrs shall not exceed 0.15 mm, per side.
4. This dimension does not include interlead flash. Interlead flash shall not exceed 0.25 mm, per side.
5. Reference JEDEC registration MS-013.

**EXAMPLE BOARD LAYOUT**

**DW0016B**

**SOIC - 2.65 mm max height**

SOIC

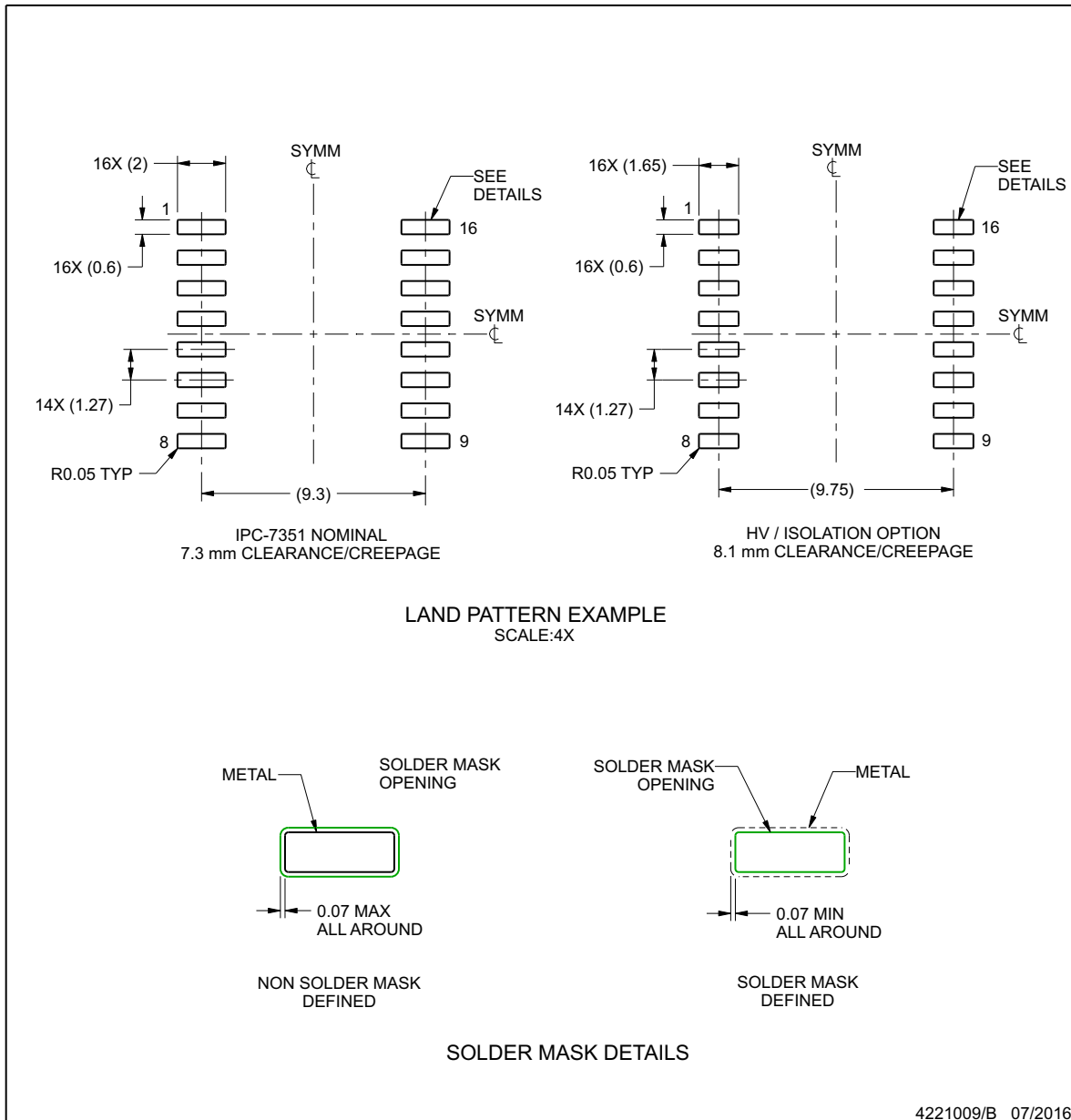

NOTES: (continued)

6. Publication IPC-7351 may have alternate designs.

7. Solder mask tolerances between and around signal pads can vary based on board fabrication site.

## EXAMPLE STENCIL DESIGN

DW0016B

SOIC - 2.65 mm max height

SOIC

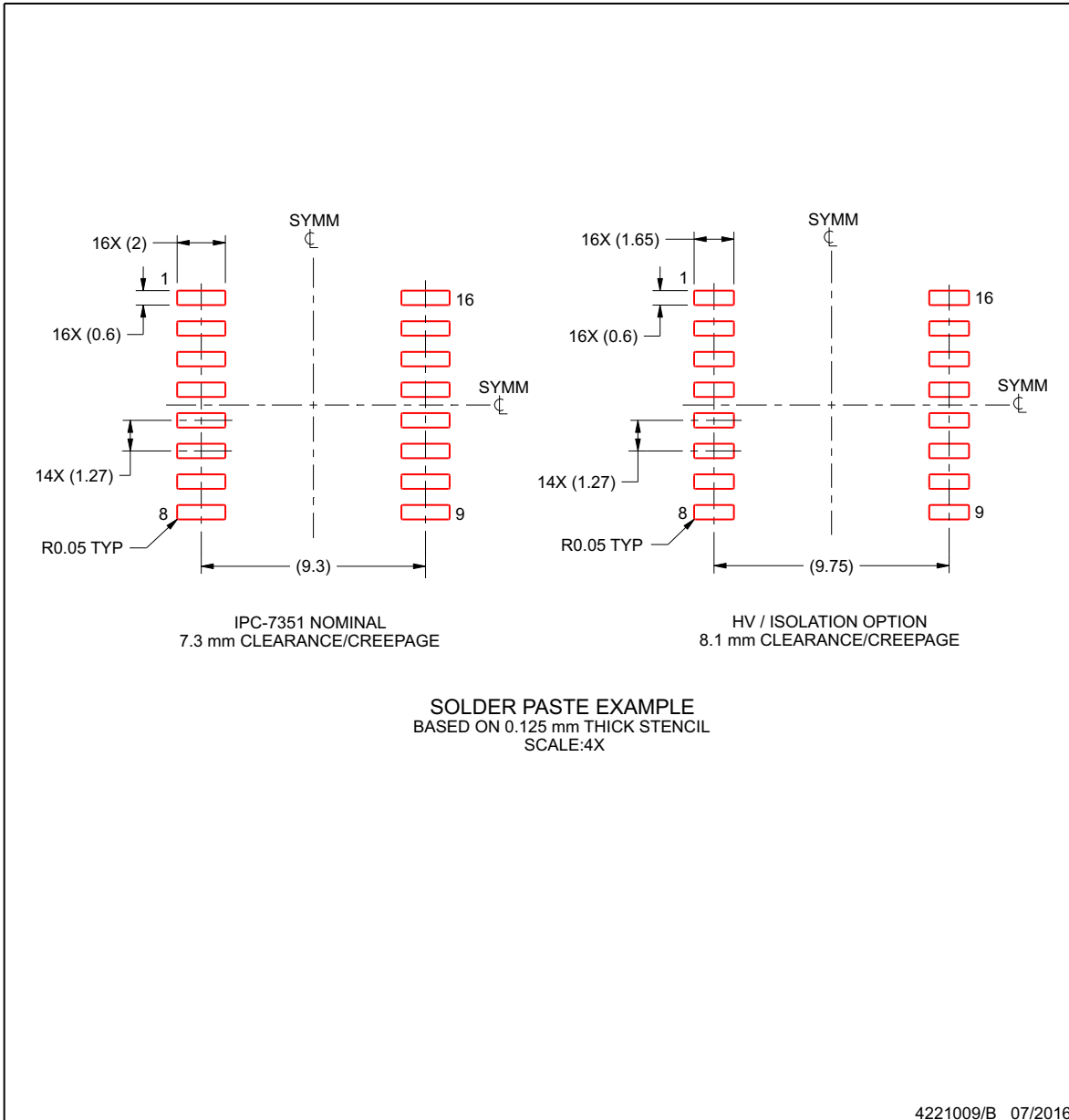

NOTES: (continued)

- 8. Laser cutting apertures with trapezoidal walls and rounded corners may offer better paste release. IPC-7525 may have alternate design recommendations.
- 9. Board assembly site may have different recommendations for stencil design.

**PACKAGING INFORMATION**

Orderable Device	Status (1)	Package Type	Package Drawing	Pins	Package Qty	Eco Plan (2)	Lead/Ball Finish (6)	MSL Peak Temp (3)	Op Temp (°C)	Device Marking (4/5)	Samples
ISO7720FQDWQ1	ACTIVE	SOIC	DW	16	40	Green (RoHS & no Sb/Br)	CU NIPDAU	Level-2-260C-1 YEAR	-40 to 125	ISO7720FQ	<a href="#">Samples</a>
ISO7720FQDWRQ1	ACTIVE	SOIC	DW	16	2000	Green (RoHS & no Sb/Br)	CU NIPDAU	Level-2-260C-1 YEAR	-40 to 125	ISO7720FQ	<a href="#">Samples</a>
ISO7720QDWQ1	ACTIVE	SOIC	DW	16	40	Green (RoHS & no Sb/Br)	CU NIPDAU	Level-2-260C-1 YEAR	-40 to 125	ISO7720Q	<a href="#">Samples</a>
ISO7720QDWRQ1	ACTIVE	SOIC	DW	16	2000	Green (RoHS & no Sb/Br)	CU NIPDAU	Level-2-260C-1 YEAR	-40 to 125	ISO7720Q	<a href="#">Samples</a>
ISO7721FQDWQ1	ACTIVE	SOIC	DW	16	40	Green (RoHS & no Sb/Br)	CU NIPDAU	Level-2-260C-1 YEAR	-40 to 125	ISO7721FQ	<a href="#">Samples</a>
ISO7721FQDWRQ1	ACTIVE	SOIC	DW	16	2000	Green (RoHS & no Sb/Br)	CU NIPDAU	Level-2-260C-1 YEAR	-40 to 125	ISO7721FQ	<a href="#">Samples</a>
ISO7721QDWQ1	ACTIVE	SOIC	DW	16	40	Green (RoHS & no Sb/Br)	CU NIPDAU	Level-2-260C-1 YEAR	-40 to 125	ISO7721Q	<a href="#">Samples</a>
ISO7721QDWRQ1	ACTIVE	SOIC	DW	16	2000	Green (RoHS & no Sb/Br)	CU NIPDAU	Level-2-260C-1 YEAR	-40 to 125	ISO7721Q	<a href="#">Samples</a>

(1) The marketing status values are defined as follows:

**ACTIVE:** Product device recommended for new designs.

**LIFEBUY:** TI has announced that the device will be discontinued, and a lifetime-buy period is in effect.

**NRND:** Not recommended for new designs. Device is in production to support existing customers, but TI does not recommend using this part in a new design.

**PREVIEW:** Device has been announced but is not in production. Samples may or may not be available.

**OBSOLETE:** TI has discontinued the production of the device.

(2) Eco Plan - The planned eco-friendly classification: Pb-Free (RoHS), Pb-Free (RoHS Exempt), or Green (RoHS & no Sb/Br) - please check <http://www.ti.com/productcontent> for the latest availability information and additional product content details.

**TBD:** The Pb-Free/Green conversion plan has not been defined.

**Pb-Free (RoHS):** TI's terms "Lead-Free" or "Pb-Free" mean semiconductor products that are compatible with the current RoHS requirements for all 6 substances, including the requirement that lead not exceed 0.1% by weight in homogeneous materials. Where designed to be soldered at high temperatures, TI Pb-Free products are suitable for use in specified lead-free processes.

**Pb-Free (RoHS Exempt):** This component has a RoHS exemption for either 1) lead-based flip-chip solder bumps used between the die and package, or 2) lead-based die adhesive used between the die and leadframe. The component is otherwise considered Pb-Free (RoHS compatible) as defined above.

**Green (RoHS & no Sb/Br):** TI defines "Green" to mean Pb-Free (RoHS compatible), and free of Bromine (Br) and Antimony (Sb) based flame retardants (Br or Sb do not exceed 0.1% by weight in homogeneous material)

(3) MSL, Peak Temp. - The Moisture Sensitivity Level rating according to the JEDEC industry standard classifications, and peak solder temperature.

(4) There may be additional marking, which relates to the logo, the lot trace code information, or the environmental category on the device.

(5) Multiple Device Markings will be inside parentheses. Only one Device Marking contained in parentheses and separated by a "~" will appear on a device. If a line is indented then it is a continuation of the previous line and the two combined represent the entire Device Marking for that device.

(6) Lead/Ball Finish - Orderable Devices may have multiple material finish options. Finish options are separated by a vertical ruled line. Lead/Ball Finish values may wrap to two lines if the finish value exceeds the maximum column width.

**Important Information and Disclaimer:**The information provided on this page represents TI's knowledge and belief as of the date that it is provided. TI bases its knowledge and belief on information provided by third parties, and makes no representation or warranty as to the accuracy of such information. Efforts are underway to better integrate information from third parties. TI has taken and continues to take reasonable steps to provide representative and accurate information but may not have conducted destructive testing or chemical analysis on incoming materials and chemicals. TI and TI suppliers consider certain information to be proprietary, and thus CAS numbers and other limited information may not be available for release.

In no event shall TI's liability arising out of such information exceed the total purchase price of the TI part(s) at issue in this document sold by TI to Customer on an annual basis.

**OTHER QUALIFIED VERSIONS OF ISO7720-Q1, ISO7721-Q1 :**

- Catalog: [ISO7720](#), [ISO7721](#)

NOTE: Qualified Version Definitions:

- Catalog - TI's standard catalog product

**TAPE AND REEL INFORMATION**

**QUADRANT ASSIGNMENTS FOR PIN 1 ORIENTATION IN TAPE**

\*All dimensions are nominal

Device	Package Type	Package Drawing	Pins	SPQ	Reel Diameter (mm)	Reel Width W1 (mm)	A0 (mm)	B0 (mm)	K0 (mm)	P1 (mm)	W (mm)	Pin1 Quadrant
ISO7720FQDWRQ1	SOIC	DW	16	2000	330.0	16.4	10.75	10.7	2.7	12.0	16.0	Q1
ISO7720QDWRQ1	SOIC	DW	16	2000	330.0	16.4	10.75	10.7	2.7	12.0	16.0	Q1
ISO7721FQDWRQ1	SOIC	DW	16	2000	330.0	16.4	10.75	10.7	2.7	12.0	16.0	Q1
ISO7721QDWRQ1	SOIC	DW	16	2000	330.0	16.4	10.75	10.7	2.7	12.0	16.0	Q1

**TAPE AND REEL BOX DIMENSIONS**

\*All dimensions are nominal

Device	Package Type	Package Drawing	Pins	SPQ	Length (mm)	Width (mm)	Height (mm)
ISO7720FQDWRQ1	SOIC	DW	16	2000	367.0	367.0	38.0
ISO7720QDWRQ1	SOIC	DW	16	2000	367.0	367.0	38.0
ISO7721FQDWRQ1	SOIC	DW	16	2000	367.0	367.0	38.0
ISO7721QDWRQ1	SOIC	DW	16	2000	367.0	367.0	38.0

DW (R-PDSO-G16)

PLASTIC SMALL OUTLINE

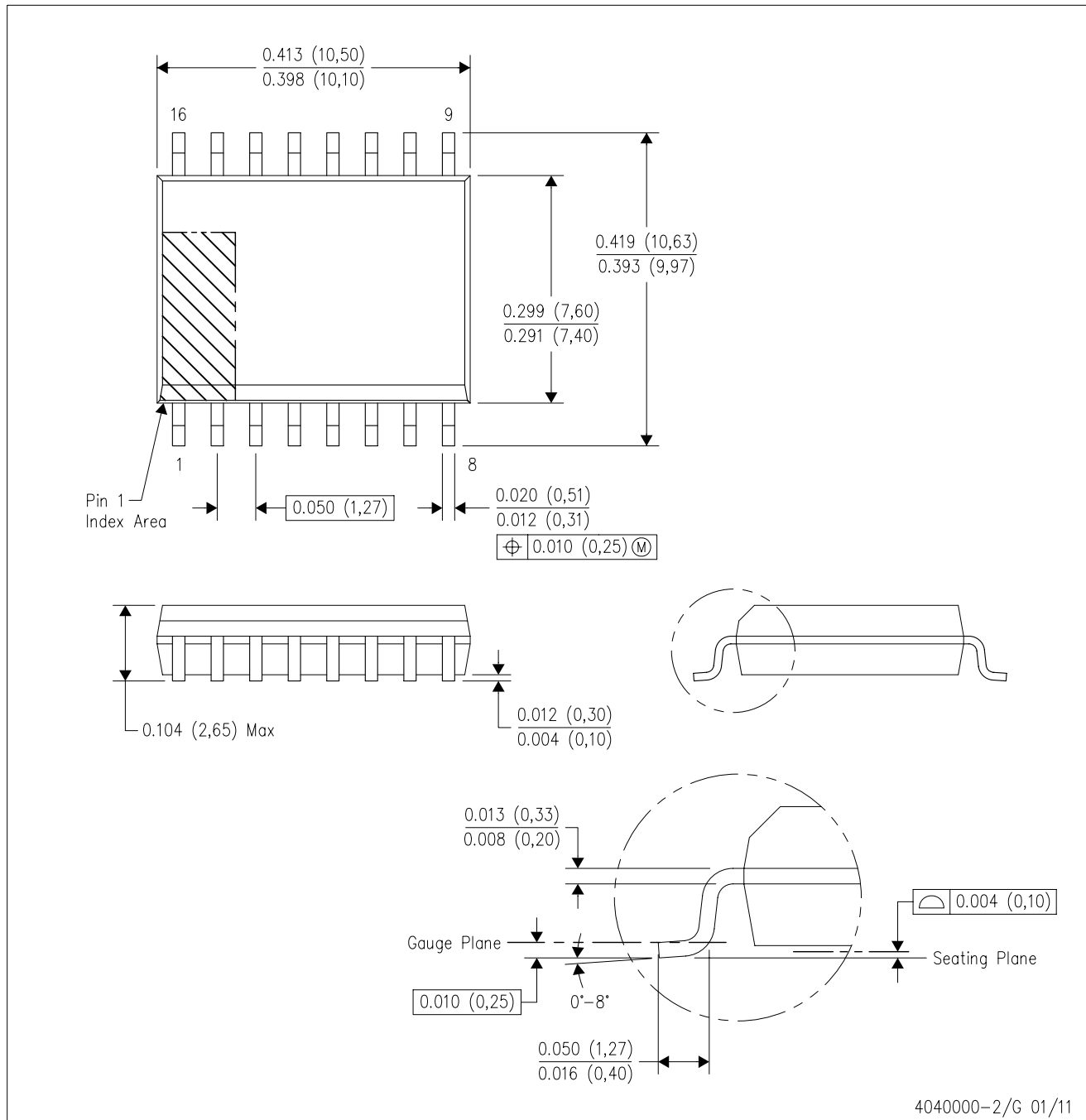

- NOTES:
- A. All linear dimensions are in inches (millimeters). Dimensioning and tolerancing per ASME Y14.5M-1994.
  - B. This drawing is subject to change without notice.
  - C. Body dimensions do not include mold flash or protrusion not to exceed 0.006 (0,15).
  - D. Falls within JEDEC MS-013 variation AA.

## IMPORTANT NOTICE

Texas Instruments Incorporated (TI) reserves the right to make corrections, enhancements, improvements and other changes to its semiconductor products and services per JESD46, latest issue, and to discontinue any product or service per JESD48, latest issue. Buyers should obtain the latest relevant information before placing orders and should verify that such information is current and complete.

TI's published terms of sale for semiconductor products (<http://www.ti.com/sc/docs/stdterms.htm>) apply to the sale of packaged integrated circuit products that TI has qualified and released to market. Additional terms may apply to the use or sale of other types of TI products and services.

Reproduction of significant portions of TI information in TI data sheets is permissible only if reproduction is without alteration and is accompanied by all associated warranties, conditions, limitations, and notices. TI is not responsible or liable for such reproduced documentation. Information of third parties may be subject to additional restrictions. Resale of TI products or services with statements different from or beyond the parameters stated by TI for that product or service voids all express and any implied warranties for the associated TI product or service and is an unfair and deceptive business practice. TI is not responsible or liable for any such statements.

Buyers and others who are developing systems that incorporate TI products (collectively, "Designers") understand and agree that Designers remain responsible for using their independent analysis, evaluation and judgment in designing their applications and that Designers have full and exclusive responsibility to assure the safety of Designers' applications and compliance of their applications (and of all TI products used in or for Designers' applications) with all applicable regulations, laws and other applicable requirements. Designer represents that, with respect to their applications, Designer has all the necessary expertise to create and implement safeguards that (1) anticipate dangerous consequences of failures, (2) monitor failures and their consequences, and (3) lessen the likelihood of failures that might cause harm and take appropriate actions. Designer agrees that prior to using or distributing any applications that include TI products, Designer will thoroughly test such applications and the functionality of such TI products as used in such applications.

TI's provision of technical, application or other design advice, quality characterization, reliability data or other services or information, including, but not limited to, reference designs and materials relating to evaluation modules, (collectively, "TI Resources") are intended to assist designers who are developing applications that incorporate TI products; by downloading, accessing or using TI Resources in any way, Designer (individually or, if Designer is acting on behalf of a company, Designer's company) agrees to use any particular TI Resource solely for this purpose and subject to the terms of this Notice.

TI's provision of TI Resources does not expand or otherwise alter TI's applicable published warranties or warranty disclaimers for TI products, and no additional obligations or liabilities arise from TI providing such TI Resources. TI reserves the right to make corrections, enhancements, improvements and other changes to its TI Resources. TI has not conducted any testing other than that specifically described in the published documentation for a particular TI Resource.

Designer is authorized to use, copy and modify any individual TI Resource only in connection with the development of applications that include the TI product(s) identified in such TI Resource. NO OTHER LICENSE, EXPRESS OR IMPLIED, BY ESTOPPEL OR OTHERWISE TO ANY OTHER TI INTELLECTUAL PROPERTY RIGHT, AND NO LICENSE TO ANY TECHNOLOGY OR INTELLECTUAL PROPERTY RIGHT OF TI OR ANY THIRD PARTY IS GRANTED HEREIN, including but not limited to any patent right, copyright, mask work right, or other intellectual property right relating to any combination, machine, or process in which TI products or services are used. Information regarding or referencing third-party products or services does not constitute a license to use such products or services, or a warranty or endorsement thereof. Use of TI Resources may require a license from a third party under the patents or other intellectual property of the third party, or a license from TI under the patents or other intellectual property of TI.

TI RESOURCES ARE PROVIDED "AS IS" AND WITH ALL FAULTS. TI DISCLAIMS ALL OTHER WARRANTIES OR REPRESENTATIONS, EXPRESS OR IMPLIED, REGARDING RESOURCES OR USE THEREOF, INCLUDING BUT NOT LIMITED TO ACCURACY OR COMPLETENESS, TITLE, ANY EPIDEMIC FAILURE WARRANTY AND ANY IMPLIED WARRANTIES OF MERCHANTABILITY, FITNESS FOR A PARTICULAR PURPOSE, AND NON-INFRINGEMENT OF ANY THIRD PARTY INTELLECTUAL PROPERTY RIGHTS. TI SHALL NOT BE LIABLE FOR AND SHALL NOT DEFEND OR INDEMNIFY DESIGNER AGAINST ANY CLAIM, INCLUDING BUT NOT LIMITED TO ANY INFRINGEMENT CLAIM THAT RELATES TO OR IS BASED ON ANY COMBINATION OF PRODUCTS EVEN IF DESCRIBED IN TI RESOURCES OR OTHERWISE. IN NO EVENT SHALL TI BE LIABLE FOR ANY ACTUAL, DIRECT, SPECIAL, COLLATERAL, INDIRECT, PUNITIVE, INCIDENTAL, CONSEQUENTIAL OR EXEMPLARY DAMAGES IN CONNECTION WITH OR ARISING OUT OF TI RESOURCES OR USE THEREOF, AND REGARDLESS OF WHETHER TI HAS BEEN ADVISED OF THE POSSIBILITY OF SUCH DAMAGES.

Unless TI has explicitly designated an individual product as meeting the requirements of a particular industry standard (e.g., ISO/TS 16949 and ISO 26262), TI is not responsible for any failure to meet such industry standard requirements.

Where TI specifically promotes products as facilitating functional safety or as compliant with industry functional safety standards, such products are intended to help enable customers to design and create their own applications that meet applicable functional safety standards and requirements. Using products in an application does not by itself establish any safety features in the application. Designers must ensure compliance with safety-related requirements and standards applicable to their applications. Designer may not use any TI products in life-critical medical equipment unless authorized officers of the parties have executed a special contract specifically governing such use. Life-critical medical equipment is medical equipment where failure of such equipment would cause serious bodily injury or death (e.g., life support, pacemakers, defibrillators, heart pumps, neurostimulators, and implantables). Such equipment includes, without limitation, all medical devices identified by the U.S. Food and Drug Administration as Class III devices and equivalent classifications outside the U.S.

TI may expressly designate certain products as completing a particular qualification (e.g., Q100, Military Grade, or Enhanced Product). Designers agree that it has the necessary expertise to select the product with the appropriate qualification designation for their applications and that proper product selection is at Designers' own risk. Designers are solely responsible for compliance with all legal and regulatory requirements in connection with such selection.

Designer will fully indemnify TI and its representatives against any damages, costs, losses, and/or liabilities arising out of Designer's non-compliance with the terms and provisions of this Notice.