

MSP430FR211x Mixed-Signal Microcontrollers

1 Device Overview

1.1 Features

- Embedded Microcontroller
 - 16-Bit RISC Architecture up to 16 MHz
 - Wide Supply Voltage Range (1.8 V to 3.6 V ⁽¹⁾)
 - Optimized Low-Power Modes (at 3 V)
 - Active Mode: 120 μ A/MHz
 - Standby
 - LPM3.5 With VLO: 1 μ A
 - Real-Time Clock (RTC) Counter (LPM3.5 With 32768-Hz Crystal): 1 μ A
 - Shutdown (LPM4.5): 34 nA Without SVS
 - Low-Power Ferroelectric RAM (FRAM)
 - Up to 3.75KB of Nonvolatile Memory
 - Built-In Error Correction Code (ECC)
 - Configurable Write Protection
 - Unified Memory of Program, Constants, and Storage
 - 10^{15} Write Cycle Endurance
 - Radiation Resistant and Nonmagnetic
 - Intelligent Digital Peripherals
 - One 16-Bit Timer With Three Capture/Compare Registers (Timer_B3)
 - One 16-Bit Counter-Only RTC Counter
 - 16-Bit Cyclic Redundancy Checker (CRC)
 - Enhanced Serial Communications
 - Enhanced USCI A (eUSCI_A) Supports UART, IrDA, and SPI
 - High-Performance Analog
 - 8-Channel 10-Bit Analog-to-Digital Converter (ADC)
 - Integrated Temperature Sensor
 - Internal 1.5-V Reference
 - Sample-and-Hold 200 ksp/s
 - Enhanced Comparator (eCOMP)
 - Integrated 6-Bit DAC as Reference Voltage
 - Programmable Hysteresis
 - Configurable High-Power and Low-Power Modes
 - Clock System (CS)
 - On-Chip 32-kHz RC Oscillator (REFO)
 - On-Chip 16-MHz Digitally Controlled Oscillator (DCO) With Frequency-Locked Loop (FLL)
 - $\pm 1\%$ Accuracy With On-Chip Reference at Room Temperature
 - On-Chip Very-Low-Frequency 10-kHz Oscillator (VLO)
 - On-Chip High-Frequency Modulation Oscillator (MODOSC)
 - External 32-kHz Crystal Oscillator (LFXT)
 - Programmable MCLK Prescaler of 1 to 128
 - SMCLK Derived From MCLK With Programmable Prescaler of 1, 2, 4, or 8
 - General Input/Output and Pin Functionality
 - 12 I/Os on 16-Pin Package
 - 8 Interrupt Pins (4 Pins of P1 and 4 Pins of P2) Can Wake MCU From LPMs
 - All I/Os are Capacitive Touch I/Os
 - Development Tools and Software (Also See [Section 8.3](#))
 - Free Professional Development Environments
 - Development Kits ([MSP-TS430PW20](#), [MSP-FET430U20](#), [MSP-EXP430FR4133](#), and [MSP-EXP430FR2311](#))
 - Family Members (Also See [Section 3](#))
 - MSP430FR2111: 3.75KB of Program FRAM + 1KB of RAM
 - MSP430FR2110: 2KB of Program FRAM + 1KB of RAM
 - Package Options
 - 16-Pin: TSSOP (PW16)
 - 24-Pin: QFN (RLL)
 - For Complete Module Descriptions, See the [MSP430FR4xx and MSP430FR2xx Family User's Guide](#)
- (1) Operation voltage is restricted by SVS levels (see V_{SVSH-} and V_{SVSH+} in [Table 5-1](#)).

1.2 Applications

- Smoke Detectors
- Power Banks
- Portable Health and Fitness
- Power Monitoring
- Personal Electronics
- E-Cigarette
- Power Tools Battery Monitoring
- E-shaver



1.3 Description

MSP430FR211x devices are an expansion of the MSP430™ microcontroller (MCU) value line to the MSP430FRx FRAM-based MCU family with up to 50x the RAM of comparable 8-bit MCUs in a 3-x3-mm² package. This ultra-low-power MCU family consists of several devices featuring embedded unified memory, which eliminates the need for assembly programming, making it easier to upgrade 8-bit designs in C and take advantage of the benefits of FRAM and integrated peripherals targeted at various applications. The architecture, FRAM, and peripherals, combined with extensive low-power modes, are optimized to achieve extended battery life in portable and wireless sensing applications. FRAM is a nonvolatile memory that combines the speed, flexibility, and endurance of SRAM with the stability and reliability of flash, all at lower total power consumption. Additionally, existing designs on the MSP430G2x family can migrate to the MSP430F211x family to increase performance and get the benefits of FRAM.

The MSP430FR211x MCU features a powerful 16-bit RISC CPU, 16-bit registers, and constant generators that contribute to maximum code efficiency. The digitally controlled oscillator (DCO) also allows the device to wake up from low-power modes to active mode typically in less than 10 μs. The feature-set of this MCU meets the needs of applications ranging from smoke detectors to power tool battery protection and fitness accessories.

Device Information⁽¹⁾

PART NUMBER	PACKAGE	BODY SIZE ⁽²⁾
MSP430FR2111PW16	TSSOP (16)	5 mm × 4.4 mm
MSP430FR2110PW16		
MSP430FR2111RLL	QFN (24)	3 mm × 3 mm
MSP430FR2110RLL		

- (1) For the most current part, package, and ordering information, see the *Package Option Addendum* in [Section 9](#), or see the TI website at www.ti.com.
- (2) The sizes shown here are approximations. For the package dimensions with tolerances, see the *Mechanical Data* in [Section 9](#).

CAUTION

System-level ESD protection must be applied in compliance with the device-level ESD specification to prevent electrical overstress or disturbing of data or code memory. See [MSP430™ System-Level ESD Considerations](#) for more information.

1.4 Functional Block Diagram

Figure 1-1 shows the functional block diagram.

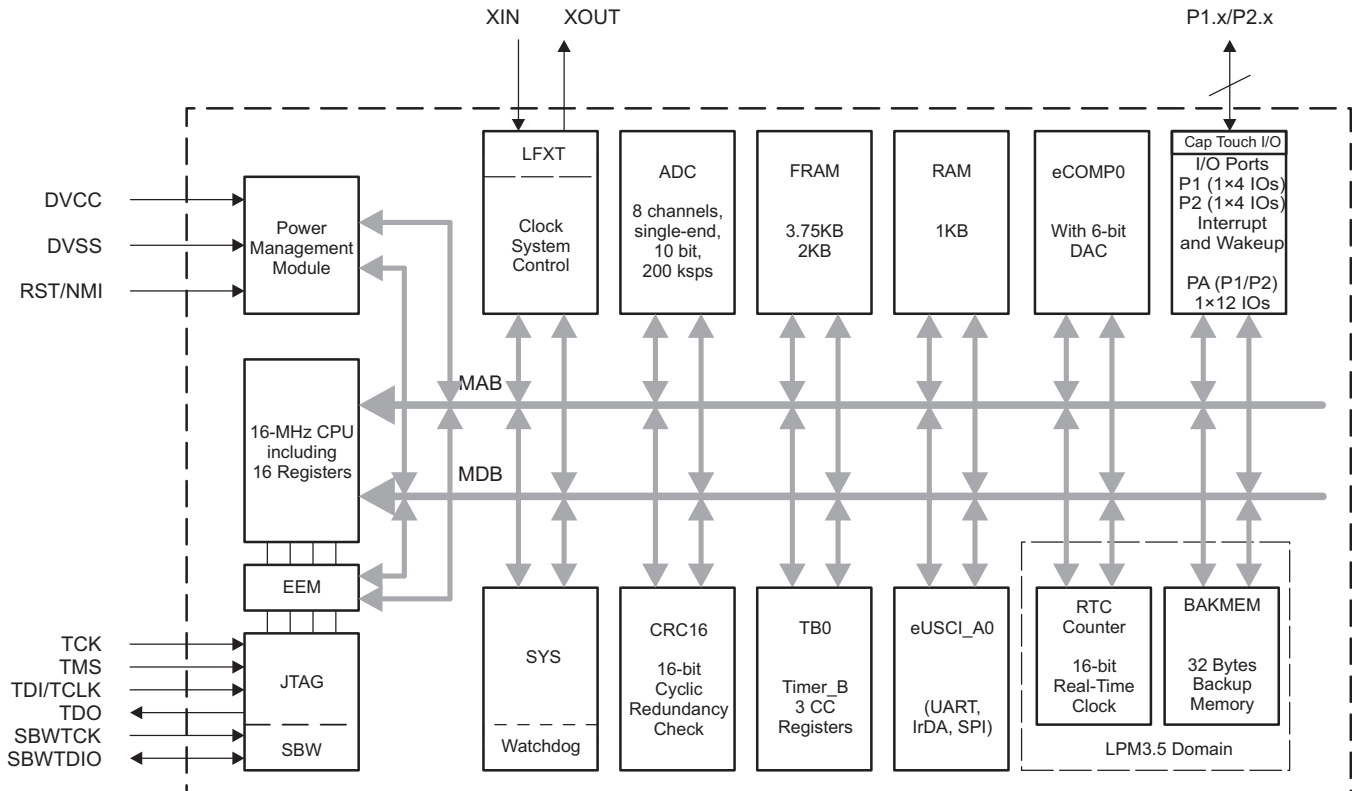

Copyright © 2016, Texas Instruments Incorporated

Figure 1-1. Functional Block Diagram

- The device has one main power pair of DVCC and DVSS that supplies both digital and analog modules. Recommended bypass and decoupling capacitors are 4.7 μ F to 10 μ F and 0.1 μ F, respectively, with $\pm 5\%$ accuracy.
- Four pins of P1 and four pins of P2 feature the pin-interrupt function and can wake the MCU from all LPMs, including LPM4, LPM3.5, and LPM4.5.
- The Timer_B3 has three capture/compare registers. Only CCR1 and CCR2 are externally connected. CCR0 registers can be used only for internal period timing and interrupt generation.
- In LPM3.5, the RTC counter and backup memory can be functional while the rest of peripherals are off.
- All general-purpose I/Os can be configured as Capacitive Touch I/Os.

Table of Contents

1	Device Overview	1	5.13	Timing and Switching Characteristics	16
1.1	Features	1	6	Detailed Description	34
1.2	Applications	1	6.1	Overview	34
1.3	Description	2	6.2	CPU	34
1.4	Functional Block Diagram	3	6.3	Operating Modes	34
2	Revision History	4	6.4	Interrupt Vector Addresses	36
3	Device Comparison	5	6.5	Memory Organization	37
3.1	Related Products	5	6.6	Bootloader (BSL)	37
4	Terminal Configuration and Functions	6	6.7	JTAG Standard Interface	37
4.1	Pin Diagrams	6	6.8	Spy-Bi-Wire Interface (SBW)	38
4.2	Pin Attributes	7	6.9	FRAM	38
4.3	Signal Descriptions	9	6.10	Memory Protection	38
4.4	Pin Multiplexing	11	6.11	Peripherals	38
4.5	Connection of Unused Pins	11	6.12	Device Descriptors (TLV)	56
4.6	Buffer Type	11	6.13	Identification	57
5	Specifications	12	7	Applications, Implementation, and Layout	58
5.1	Absolute Maximum Ratings	12	7.1	Device Connection and Layout Fundamentals	58
5.2	ESD Ratings	12	7.2	Peripheral- and Interface-Specific Design Information	61
5.3	Recommended Operating Conditions	12	7.3	Typical Applications	62
5.4	Active Mode Supply Current Into V_{CC} Excluding External Current	13	8	Device and Documentation Support	63
5.5	Active Mode Supply Current Per MHz	13	8.1	Getting Started and Next Steps	63
5.6	Low-Power Mode LPM0 Supply Currents Into V_{CC} Excluding External Current	13	8.2	Device Nomenclature	63
5.7	Low-Power Mode LPM3, LPM4 Supply Currents (Into V_{CC}) Excluding External Current	14	8.3	Tools and Software	65
5.8	Typical Characteristics – LPM3 Supply Currents	14	8.4	Documentation Support	67
5.9	Low-Power Mode LPMx.5 Supply Currents (Into V_{CC}) Excluding External Current	15	8.5	Related Links	68
5.10	Typical Characteristics – LPMx.5 Supply Currents	15	8.6	Community Resources	68
5.11	Typical Characteristics - Current Consumption Per Module	15	8.7	Trademarks	68
5.12	Thermal Resistance Characteristics	16	8.8	Electrostatic Discharge Caution	68
			8.9	Glossary	68
			9	Mechanical, Packaging, and Orderable Information	69

2 Revision History

Changes from August 11, 2016 to August 12, 2016

Page

- Changed document status from Product Preview to Production Data..... [1](#)

3 Device Comparison

Table 3-1 summarizes the features of the available family members.

Table 3-1. Device Comparison⁽¹⁾ (2)

DEVICE	PROGRAM FRAM (Kbytes)	SRAM (Bytes)	TB0	eUSCI_A	10-BIT ADC CHANNELS	eCOMP0	I/O	PACKAGE TYPE
MSP430FR2111IPW16	3.75	1024	3 × CCR ⁽³⁾	1	8	1	12	16 PW (TSSOP)
MSP430FR2110IPW16	2	1024	3 × CCR ⁽³⁾	1	8	1	12	16 PW (TSSOP)
MSP430FR2111IRLL	3.75	1024	3 × CCR ⁽³⁾	1	8	1	12	24 RLL (QFN)
MSP430FR2110IRLL	2	1024	3 × CCR ⁽³⁾	1	8	1	12	24 RLL (QFN)

- (1) For the most current device, package, and ordering information, see the *Package Option Addendum* in Section 9, or see the TI website at www.ti.com.
- (2) Package drawings, standard packing quantities, thermal data, symbolization, and PCB design guidelines are available at www.ti.com/packaging
- (3) A CCR register is a configurable register that provides internal and external capture or compare inputs, or internal and external PWM outputs.

3.1 Related Products

For information about other devices in this family of products or related products, see the following links.

Products for TI 16-bit and 32-bit Microcontrollers Low-power and high-performance MCUs, with wired and wireless connectivity options.

Products for MSP430 Ultra-Low-Power Microcontrollers One platform. One ecosystem. Endless possibilities. Enabling the connected world with innovations in ultra-low-power microcontrollers with advanced peripherals for precise sensing and measurement.

MSP430FRxx FRAM Microcontrollers 16-bit microcontrollers for ultra-low-power sensing and system management in building automation, smart grid, and industrial designs.

Companion Products for MSP430FR2111 Review products that are frequently purchased or used with this product.

Reference Designs for MSP430FR2111 The TI Designs Reference Design Library is a robust reference design library that spans analog, embedded processor, and connectivity. Created by TI experts to help you jump start your system design, all TI Designs include schematic or block diagrams, BOMs, and design files to speed your time to market. Search and download designs at ti.com/tidesigns.

4 Terminal Configuration and Functions

4.1 Pin Diagrams

Figure 4-1 shows the pinout of the 16-pin PW package.

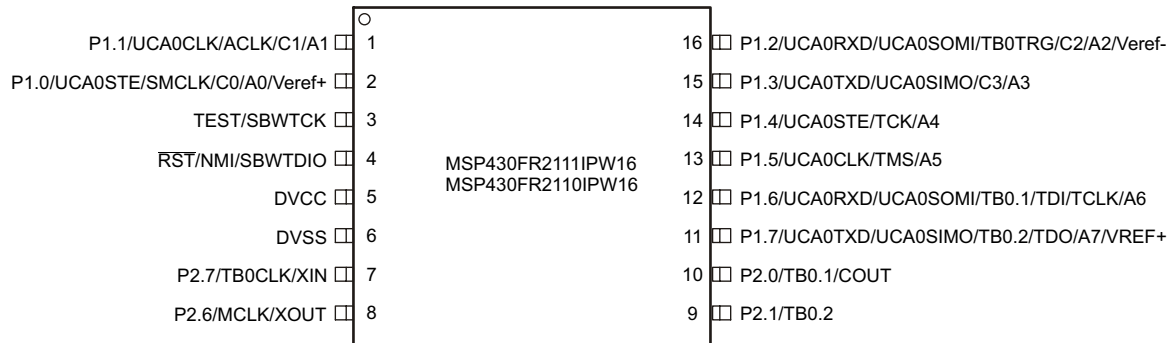

Figure 4-1. 16-Pin PW (TSSOP) (Top View)

Figure 4-2 shows the pinout of the 24-pin RLL package.

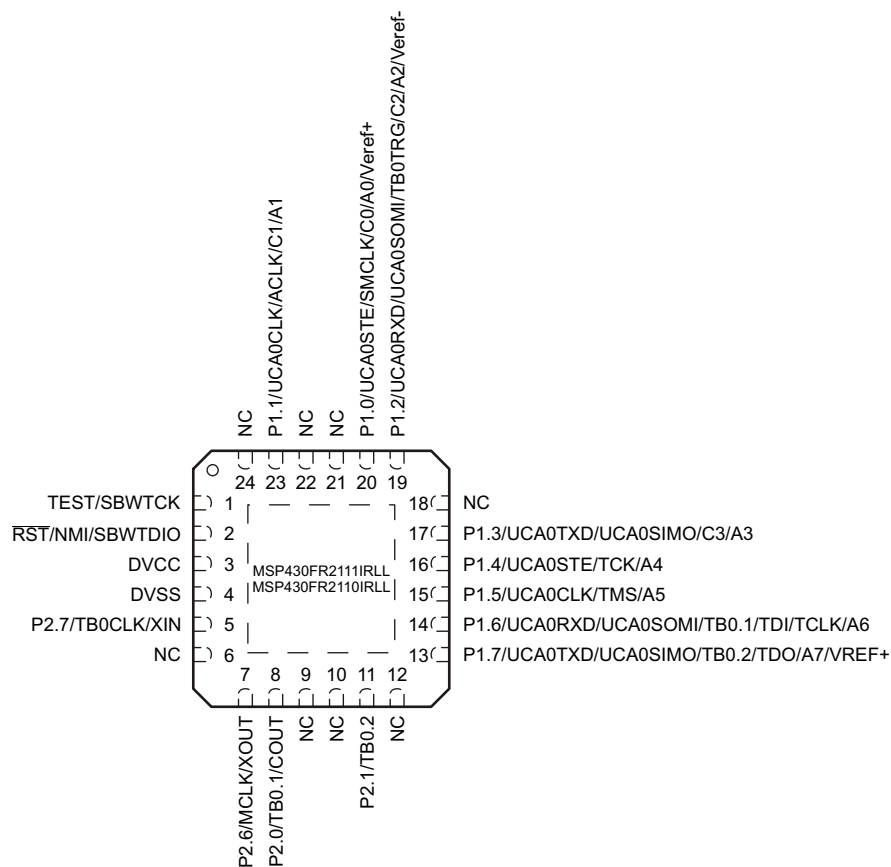

Figure 4-2. 24-Pin RLL (QFN) (Top View)

4.2 Pin Attributes

Table 4-1 lists the attributes of all pins.

Table 4-1. Pin Attributes

PIN NUMBER		SIGNAL NAME ^{(1) (2)}	SIGNAL TYPE ⁽³⁾	BUFFER TYPE ⁽⁴⁾	POWER SOURCE	RESET STATE AFTER BOR ⁽⁵⁾
PW16	RLL					
1	23	P1.1 (RD)	I/O	LVC MOS	DVCC	OFF
		UCA0CLK	I/O	LVC MOS	DVCC	–
		ACLK	O	LVC MOS	DVCC	–
		C1	I	Analog	DVCC	–
		A1	I	Analog	DVCC	–
2	20	P1.0 (RD)	I/O	LVC MOS	DVCC	OFF
		UCA0STE	I/O	LVC MOS	DVCC	–
		SMCLK	O	LVC MOS	DVCC	–
		C0	I	Analog	DVCC	–
		A0	I	Analog	DVCC	–
		Veref+	I	Power	DVCC	–
3	1	TEST (RD)	I	LVC MOS	DVCC	OFF
		SBWTCK	I	LVC MOS	DVCC	–
4	2	$\overline{\text{RST}}$ (RD)	I/O	LVC MOS	DVCC	OFF
		NMI	I	LVC MOS	DVCC	–
		SBWTDIO	I/O	LVC MOS	DVCC	–
5	3	DVCC	P	Power	DVCC	N/A
6	4	DVSS	P	Power	DVCC	N/A
7	5	P2.7 (RD)	I/O	LVC MOS	DVCC	OFF
		TB0CLK	I	LVC MOS	DVCC	–
		XIN	I	LVC MOS	DVCC	–
8	7	P2.6 (RD)	I/O	LVC MOS	DVCC	OFF
		MCLK	O	LVC MOS	DVCC	–
		XOUT	O	LVC MOS	DVCC	–
9	11	P2.1(RD)	I/O	LVC MOS	DVCC	OFF
		TB0.2	I/O	LVC MOS	DVCC	–
10	8	P2.0 (RD)	I/O	LVC MOS	DVCC	OFF
		TB0.1	I/O	LVC MOS	DVCC	–
		COUT	O	LVC MOS	DVCC	–
11	13	P1.7 (RD)	I/O	LVC MOS	DVCC	OFF
		UCA0TXD	O	LVC MOS	DVCC	–
		UCA0SIMO	I/O	LVC MOS	DVCC	–
		TB0.2	I/O	LVC MOS	DVCC	–
		TDO	O	LVC MOS	DVCC	–
		A7	I	Analog	DVCC	–
		VREF+	O	Power	DVCC	–

(1) Signals names with (RD) denote the reset default pin name.

(2) To determine the pin mux encodings for each pin, see [Section 6.11.15, Input/Output Diagrams](#).

(3) Signal Types: I = Input, O = Output, I/O = Input or Output.

(4) Buffer Types: LVC MOS, Analog, or Power

(5) Reset States:

OFF = High-impedance input with pullup or pulldown disabled (if available)

N/A = Not applicable

Table 4-1. Pin Attributes (continued)

PIN NUMBER		SIGNAL NAME ^{(1) (2)}	SIGNAL TYPE ⁽³⁾	BUFFER TYPE ⁽⁴⁾	POWER SOURCE	RESET STATE AFTER BOR ⁽⁵⁾
PW16	RLL					
12	14	P1.6 (RD)	I/O	LVC MOS	DVCC	OFF
		UCA0RXD	I	LVC MOS	DVCC	–
		UCA0SOMI	I/O	LVC MOS	DVCC	–
		TB0.1	I/O	LVC MOS	DVCC	–
		TDI	I	LVC MOS	DVCC	–
		TCLK	I	LVC MOS	DVCC	–
		A6	I	Analog	DVCC	–
13	15	P1.5 (RD)	I/O	LVC MOS	DVCC	OFF
		UCA0CLK	I/O	LVC MOS	DVCC	–
		TMS	I	LVC MOS	DVCC	–
		A5	I	Analog	DVCC	–
14	16	P1.4 (RD)	I/O	LVC MOS	DVCC	OFF
		UCA0STE	I/O	LVC MOS	DVCC	–
		TCK	I	LVC MOS	DVCC	–
		A4	I	Analog	DVCC	–
15	17	P1.3 (RD)	I/O	LVC MOS	DVCC	OFF
		UCA0TXD	O	LVC MOS	DVCC	–
		UCA0SIMO	I/O	LVC MOS	DVCC	–
		C3	I	Analog	DVCC	–
		A3	I	Analog	DVCC	–
16	19	P1.2 (RD)	I/O	LVC MOS	DVCC	OFF
		UCA0RXD	I	LVC MOS	DVCC	–
		UCA0SOMI	I/O	LVC MOS	DVCC	–
		TB0TRG	I	LVC MOS	DVCC	–
		C2	I	Analog	DVCC	–
		A2	I	Analog	DVCC	–
		Verif-	I	Power	DVCC	–
	6, 9, 10, 12, 18, 21, 22, 24	NC ⁽⁶⁾	–	–	–	–

(6) NC = Not connect

4.3 Signal Descriptions

Table 4-2 describes the signals for all device variants and package options.

Table 4-2. Signal Descriptions

FUNCTION	SIGNAL NAME	PIN NUMBER		PIN TYPE	DESCRIPTION
		PW16	RLL		
ADC	A0	2	20	I	Analog input A0
	A1	1	23	I	Analog input A1
	A2	16	19	I	Analog input A2
	A3	15	17	I	Analog input A3
	A4	14	16	I	Analog input A4
	A5	13	15	I	Analog input A5
	A6	12	14	I	Analog input A6
	A7	11	13	I	Analog input A7
	Veref+	2	20	I	ADC positive reference
	Veref-	16	19	I	ADC negative reference
eCOMP0	C0	2	20	I	Comparator input channel C0
	C1	1	23	I	Comparator input channel C1
	C2	16	19	I	Comparator input channel C2
	C3	15	17	I	Comparator input channel C3
	COUT	10	8	O	Comparator output channel COUT
Clock	ACLK	1	23	O	ACLK output
	MCLK	8	7	O	MCLK output
	SMCLK	2	20	O	SMCLK output
	XIN	7	5	I	Input terminal for crystal oscillator
	XOUT	8	7	O	Output terminal for crystal oscillator
Debug	SBWTCK	3	1	I	Spy-Bi-Wire input clock
	SBWTDIO	4	2	I/O	Spy-Bi-Wire data input/output
	TCK	14	16	I	Test clock
	TCLK	12	14	I	Test clock input
	TDI	12	14	I	Test data input
	TDO	11	13	O	Test data output
	TMS	13	15	I	Test mode select
	TEST	3	1	I	Test mode pin – selected digital I/O on JTAG pins
System	NMI	4	2	I	Nonmaskable interrupt input
	$\overline{\text{RST}}$	4	2	I/O	Reset input, active low
Power	DVCC	5	3	P	Power supply
	DVSS	6	4	P	Power ground
	VREF+	11	13	P	Output of positive reference voltage with ground as reference

Table 4-2. Signal Descriptions (continued)

FUNCTION	SIGNAL NAME	PIN NUMBER		PIN TYPE	DESCRIPTION
		PW16	RLL		
GPIO	P1.0	2	20	I/O	General-purpose I/O
	P1.1	1	23	I/O	General-purpose I/O
	P1.2	16	19	I/O	General-purpose I/O
	P1.3	15	17	I/O	General-purpose I/O
	P1.4	14	16	I/O	General-purpose I/O ⁽¹⁾
	P1.5	13	15	I/O	General-purpose I/O ⁽¹⁾
	P1.6	12	14	I/O	General-purpose I/O ⁽¹⁾
	P1.7	11	13	I/O	General-purpose I/O ⁽¹⁾
	P2.0	10	8	I/O	General-purpose I/O
	P2.1	9	11	I/O	General-purpose I/O
	P2.6	8	7	I/O	General-purpose I/O
	P2.7	7	5	I/O	General-purpose I/O
	SPI and UART	UCA0CLK	13	15	I/O
UCA0RXD		12	14	I	eUSCI_A0 UART receive data
UCA0SIMO		11	13	I/O	eUSCI_A0 SPI slave in/master out
UCA0SOMI		12	14	I/O	eUSCI_A0 SPI slave out/master in
UCA0STE		14	16	I/O	eUSCI_A0 SPI slave transmit enable
UCA0TXD		11	13	O	eUSCI_A0 UART transmit data
UCA0CLK ⁽²⁾		1	23	I/O	eUSCI_A0 SPI clock input/output
UCA0RXD ⁽²⁾		16	19	I	eUSCI_A0 UART receive data
UCA0SIMO ⁽²⁾		15	17	I/O	eUSCI_A0 SPI slave in/master out
UCA0SOMI ⁽²⁾		16	19	I/O	eUSCI_A0 SPI slave out/master in
UCA0STE ⁽²⁾		2	20	I/O	eUSCI_A0 SPI slave transmit enable
UCA0TXD ⁽²⁾	15	17	O	eUSCI_A0 UART transmit data	
Timer_B	TB0.1	12	14	I/O	Timer TB0 CCR1 capture: CCI1A input, compare: Out1 outputs
	TB0.2	11	13	I/O	Timer TB0 CCR2 capture: CCI2A input, compare: Out2 outputs
	TB0CLK	7	5	I	Timer clock input TBCLK for TB0
	TB0TRG	16	19	I	TB0 external trigger input for TB0OUTH
	TB0.1 ⁽³⁾	10	8	I/O	Timer TB0 CCR1 capture: CCI1A input, compare: Out1 outputs
	TB0.2 ⁽³⁾	9	11	I/O	Timer TB0 CCR2 capture: CCI2A input, compare: Out2 outputs
NC Pad	NC	–	6, 9, 10, 12, 18, 21, 22, 24	–	Do not connect
QFN Pad	Pad	–	Pad		QFN package exposed thermal pad. Connect to V _{SS} .

- (1) Because this pin is multiplexed with the JTAG function, TI recommends disabling the pin interrupt function while in JTAG debug to prevent collisions.
- (2) This is the remapped functionality controlled by the USCIARMP bit in the SYSCFG3 register. Only one selected port is valid at the same time when TB0 acts as capture input functionality. TB0 PWM outputs regardless of this remap bit control.
- (3) This is the remapped functionality controlled by the TBRMP bit in the SYSCFG3 register. Only one selected port is valid at the same time.

4.4 Pin Multiplexing

Pin multiplexing for these devices is controlled by both register settings and operating modes (for example, if the device is in test mode). For details of the settings for each pin and schematics of the multiplexed ports, see [Section 6.11.15](#).

4.5 Connection of Unused Pins

[Table 4-3](#) lists the correct termination of unused pins.

Table 4-3. Connection of Unused Pins⁽¹⁾

PIN	POTENTIAL	COMMENT
Px.0 to Px.7	Open	Set to port function, output direction (PxDIR.n = 1)
$\overline{\text{RST}}/\text{NMI}$	DVCC	47-k Ω pullup or internal pullup selected with 10-nF (1.1 nF) pulldown ⁽²⁾
TEST	Open	This pin always has an internal pulldown enabled.

- (1) Any unused pin with a secondary function that is shared with general-purpose I/O should follow the Px.0 to Px.7 unused pin connection guidelines.
- (2) The pulldown capacitor should not exceed 1.1 nF when using devices with Spy-Bi-Wire interface in Spy-Bi-Wire mode with TI tools like FET interfaces or GANG programmers.

4.6 Buffer Type

[Table 4-4](#) defines the pin buffer types that are listed in [Table 4-1](#).

Table 4-4. Buffer Type

BUFFER TYPE (STANDARD)	NOMINAL VOLTAGE	HYSTERESIS	PU OR PD	NOMINAL PU OR PD STRENGTH (μA)	OUTPUT DRIVE STRENGTH (mA)	OTHER CHARACTERISTICS
LVC MOS	3.0 V	Υ ⁽¹⁾	Programmable	See Section 5.13.4	See Section 5.13.4.1	
Analog	3.0 V	No	No	N/A	N/A	See analog modules in Section 5 for details.
Power (DVCC)	3.0 V	No	No	N/A	N/A	SVS enables hysteresis on DVCC.
Power (AVCC)	3.0 V	No	No	N/A	N/A	

- (1) Only for input pins

5 Specifications

5.1 Absolute Maximum Ratings⁽¹⁾

Over operating free-air temperature range (unless otherwise noted)

	MIN	MAX	UNIT
Voltage applied at DVCC pin to V _{SS}	-0.3	4.1	V
Voltage applied to any pin ⁽²⁾	-0.3	V _{CC} + 0.3 (4.1 V Max)	V
Diode current at any device pin		±2	mA
Maximum junction temperature, T _J		85	°C
Storage temperature range, T _{stg} ⁽³⁾	-40	125	°C

- (1) Stresses beyond those listed under *Absolute Maximum Ratings* may cause permanent damage to the device. These are stress ratings only, and functional operation of the device at these or any other conditions beyond those indicated under *Recommended Operating Conditions* is not implied. Exposure to absolute-maximum-rated conditions for extended periods may affect device reliability.
- (2) All voltages referenced to V_{SS}.
- (3) Higher temperature may be applied during board soldering according to the current JEDEC J-STD-020 specification with peak reflow temperatures not higher than classified on the device label on the shipping boxes or reels.

5.2 ESD Ratings

		VALUE	UNIT
V _(ESD)	Electrostatic discharge		
	Human-body model (HBM), per ANSI/ESDA/JEDEC JS-001 ⁽¹⁾	±1000	V
Charged-device model (CDM), per JEDEC specification JESD22-C101 ⁽²⁾	±250		

- (1) JEDEC document JEP155 states that 500-V HBM allows safe manufacturing with a standard ESD control process. Manufacturing with less than 500-V HBM is possible with the necessary precautions. Pins listed as ±1000 V may actually have higher performance.
- (2) JEDEC document JEP157 states that 250-V CDM allows safe manufacturing with a standard ESD control process. Manufacturing with less than 250-V CDM is possible with the necessary precautions. Pins listed as ±250 V may actually have higher performance.

5.3 Recommended Operating Conditions

		MIN	NOM	MAX	UNIT
V _{CC}	Supply voltage applied at DVCC pin ⁽¹⁾ ⁽²⁾	1.8		3.6	V
V _{SS}	Supply voltage applied at DVSS pin		0		V
T _A	Operating free-air temperature	-40		85	°C
T _J	Operating junction temperature	-40		85	°C
C _{DVCC}	Recommended capacitor at DVCC	4.7	10		µF
f _{SYSTEM}	Processor frequency (maximum MCLK frequency) ⁽³⁾ ⁽⁴⁾	No FRAM wait states (NWAITSx = 0)		8	MHz
		With FRAM wait states (NWAITSx = 1) ⁽⁵⁾	0	16 ⁽⁶⁾	
f _{ACLK}	Maximum ACLK frequency			40	kHz
f _{SMCLK}	Maximum SMCLK frequency			16 ⁽⁶⁾	MHz

- (1) Supply voltage changes faster than 0.2 V/µs can trigger a BOR reset even within the recommended supply voltage range.
- (2) Modules may have a different supply voltage range specification. See the specification of the respective module in this data sheet.
- (3) The minimum supply voltage is defined by the SVS levels. See the SVS threshold parameters in [Table 5-1](#).
- (4) Modules may have a different maximum input clock specification. See the specification of the respective module in this data sheet.
- (5) Wait states only occur on actual FRAM accesses (that is, on FRAM cache misses). RAM and peripheral accesses are always executed without wait states.
- (6) If clock sources such as HF crystals or the DCO with frequencies >16 MHz are used, the clock must be divided in the clock system to comply with this operating condition.

5.4 Active Mode Supply Current Into V_{CC} Excluding External Current

 See ⁽¹⁾

PARAMETER	EXECUTION MEMORY	TEST CONDITION	Frequency ($f_{MCLK} = f_{SMCLK}$)						UNIT
			1 MHz 0 wait states (NWAITSx = 0)		8 MHz 0 wait states (NWAITSx = 0)		16 MHz 1 wait state (NWAITSx = 1)		
			TYP	MAX	TYP	MAX	TYP	MAX	
$I_{AM, FRAM}$ (0%)	FRAM 0% cache hit ratio	3.0 V, 25°C	460		2670		2940	μA	
		3.0 V, 85°C	475		2730		2980		
$I_{AM, FRAM}$ (100%)	FRAM 100% cache hit ratio	3.0 V, 25°C	191		570		942	μA	
		3.0 V, 85°C	199		585		960		
$I_{AM, RAM}$ ⁽²⁾	RAM	3.0 V, 25°C	213		739		1244	μA	

(1) All inputs are tied to 0 V or to V_{CC} . Outputs do not source or sink any current. Characterized with program executing typical data processing.

$f_{ACLK} = 32768$ Hz, $f_{MCLK} = f_{SMCLK} = f_{DCO}$ at specified frequency

Program and data entirely reside in FRAM. All execution is from FRAM.

(2) Program and data reside entirely in RAM. All execution is from RAM. No access to FRAM.

5.5 Active Mode Supply Current Per MHz

 $V_{CC} = 3.0$ V, $T_A = 25^\circ C$ (unless otherwise noted)

PARAMETER	TEST CONDITIONS	TYP	UNIT
$dI_{AM,FRAM}/df$ Active mode current consumption per MHz, execution from FRAM, no wait states ⁽¹⁾	$[(I_{AM} \text{ 75\% cache hit rate at 8 MHz}) - (I_{AM} \text{ 75\% cache hit rate at 1 MHz})] / 7$ MHz	120	$\mu A/MHz$

(1) All peripherals are turned on in default settings.

5.6 Low-Power Mode LPM0 Supply Currents Into V_{CC} Excluding External Current

 $V_{CC} = 3.0$ V, $T_A = 25^\circ C$ (unless otherwise noted) ⁽¹⁾ ⁽²⁾

PARAMETER	V_{CC}	FREQUENCY (f_{SMCLK})						UNIT
		1 MHz		8 MHz		16 MHz		
		TYP	MAX	TYP	MAX	TYP	MAX	
I_{LPM0}	2.0 V	148		295		398	μA	
	3.0 V	157		304		402		

(1) All inputs are tied to 0 V or to V_{CC} . Outputs do not source or sink any current.

(2) Current for watchdog timer clocked by SMCLK included.

$f_{ACLK} = 32768$ Hz, $f_{MCLK} = 0$ MHz, f_{SMCLK} at specified frequency.

5.7 Low-Power Mode LPM3, LPM4 Supply Currents (Into V_{CC}) Excluding External Current

over recommended ranges of supply voltage and operating free-air temperature (unless otherwise noted) ⁽¹⁾ (see [Figure 5-1](#) and [Figure 5-2](#))

PARAMETER	V_{CC}	-40°C		25°C		85°C		UNIT
		TYP	MAX	TYP	MAX	TYP	MAX	
$I_{LPM3,XT1}$ Low-power mode 3, includes SVS ^{(2) (3) (4)}	3.0 V	0.95		1.07		2.13	6.00	μA
	2.0 V	0.92		1.03		2.09		
$I_{LPM3,VLO}$ Low-power mode 3, VLO, excludes SVS ⁽⁵⁾	3.0 V	0.76		0.87		1.94	5.70	μA
	2.0 V	0.74		0.85		1.90		
$I_{LPM3,RTC}$ Low-power mode 3, RTC, excludes SVS ⁽⁶⁾	3.0 V	0.88		1.00		2.06		μA
	2.0 V	0.86		0.98		2.02		
$I_{LPM4,SVS}$ Low-power mode 4, includes SVS	3.0 V	0.49		0.58		1.60		μA
	2.0 V	0.46		0.56		1.57		
I_{LPM4} Low-power mode 4, excludes SVS	3.0 V	0.33		0.42		1.44		μA
	2.0 V	0.32		0.41		1.42		
$I_{LPM4,RTC,VLO}$ Low-power mode 4, RTC is sourced from VLO, excludes SVS	3.0 V	0.48		0.59		1.91		μA
	2.0 V	0.48		0.58		1.89		
$I_{LPM4,RTC,XT1}$ Low-power mode 4, RTC is sourced from XT1, excludes SVS	3.0 V	0.89		1.04		2.41		μA
	2.0 V	0.88		1.02		2.38		

- (1) All inputs are tied to 0 V or to V_{CC} . Outputs do not source or sink any current
- (2) Not applicable for devices with HF crystal oscillator only.
- (3) Characterized with a Seiko Crystal SC-32S MS1V-T1K crystal with a load capacitance chosen to closely match the required load.
- (4) Low-power mode 3, includes SVS test conditions:
Current for watchdog timer clocked by ACLK and RTC clocked by XT1 included. Current for brownout and SVS included (SVSHE = 1).
CPUOFF = 1, SCG0 = 1 SCG1 = 1, OSCOFF = 0 (LPM3),
 $f_{XT1} = 32768 \text{ Hz}$, $f_{ACLK} = f_{XT1}$, $f_{MCLK} = f_{SMCLK} = 0 \text{ MHz}$
- (5) Low-power mode 3, VLO, excludes SVS test conditions:
Current for watchdog timer clocked by VLO included. RTC disabled. Current for brownout included. SVS disabled (SVSHE = 0).
CPUOFF = 1, SCG0 = 1 SCG1 = 1, OSCOFF = 0 (LPM3),
 $f_{XT1} = 32768 \text{ Hz}$, $f_{MCLK} = f_{SMCLK} = 0 \text{ MHz}$
- (6) RTC periodically wakes every second with external 32768-Hz as source.

5.8 Typical Characteristics – LPM3 Supply Currents

3 V at 25°C and 3 V at 85°C

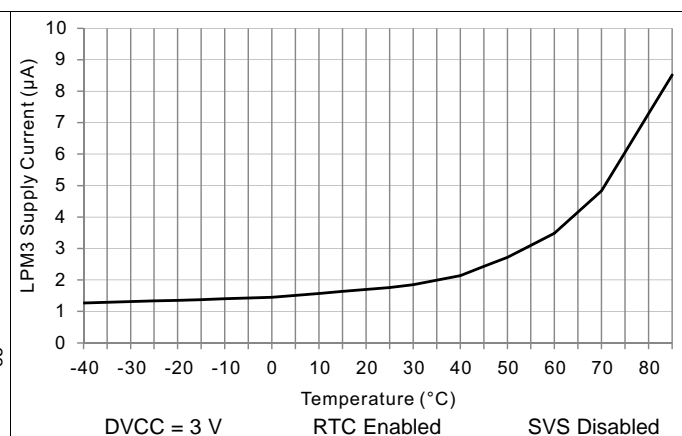
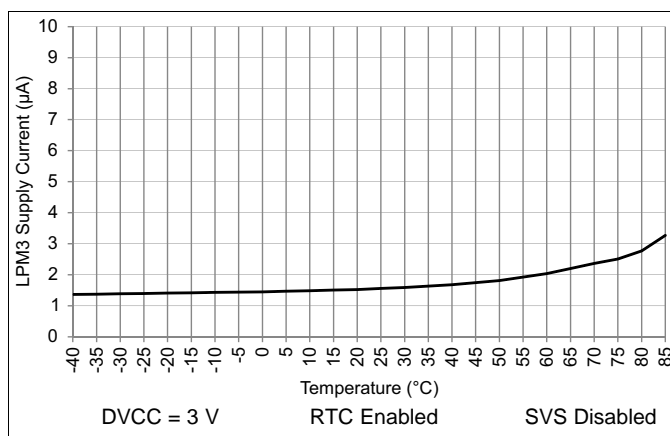

5.9 Low-Power Mode LPMx.5 Supply Currents (Into V_{CC}) Excluding External Current

over recommended ranges of supply voltage and operating free-air temperature (unless otherwise noted)

PARAMETER	V _{CC}	-40°C		25°C		85°C		UNIT
		TYP	MAX	TYP	MAX	TYP	MAX	
I _{LPM3.5, XT1} Low-power mode 3.5, includes SVS ^{(1) (2) (3)} (also see Figure 5-3)	3.0 V	0.60		0.66		0.80	2.17	μA
	2.0 V	0.57		0.64		0.75		
I _{LPM4.5, SVS} Low-power mode 4.5, includes SVS ⁽⁴⁾	3.0 V	0.23		0.25		0.32	0.43	μA
	2.0 V	0.20		0.23		0.27		
I _{LPM4.5} Low-power mode 4.5, excludes SVS ⁽⁵⁾ (also see Figure 5-4)	3.0 V	0.025		0.034		0.064	0.130	μA
	2.0 V	0.021		0.029		0.055		

- (1) Not applicable for devices with HF crystal oscillator only.
- (2) Characterized with a Seiko Crystal SC-32S crystal with a load capacitance chosen to closely match the required load.
- (3) Low-power mode 3.5, includes SVS test conditions:
Current for RTC clocked by XT1 included. Current for brownout and SVS included (SVSHE = 1). Core regulator disabled.
PMMREGOFF = 1, CPUOFF = 1, SCG0 = 1 SCG1 = 1, OSCOFF = 1 (LPMx.5),
f_{XT1} = 32768 Hz, f_{ACLK} = f_{XT1}, f_{MCLK} = f_{SMCLK} = 0 MHz
- (4) Low-power mode 4.5, includes SVS test conditions:
Current for brownout and SVS included (SVSHE = 1). Core regulator disabled.
PMMREGOFF = 1, CPUOFF = 1, SCG0 = 1 SCG1 = 1, OSCOFF = 1 (LPMx.5),
f_{XT1} = 0 Hz, f_{ACLK} = f_{MCLK} = f_{SMCLK} = 0 MHz
- (5) Low-power mode 4.5, excludes SVS test conditions:
Current for brownout included. SVS disabled (SVSHE = 0). Core regulator disabled.
PMMREGOFF = 1, CPUOFF = 1, SCG0 = 1 SCG1 = 1, OSCOFF = 1 (LPMx.5),
f_{XT1} = 0 Hz, f_{ACLK} = f_{MCLK} = f_{SMCLK} = 0 MHz

5.10 Typical Characteristics – LPMx.5 Supply Currents

3 V at 25°C and 3 V at 85°C

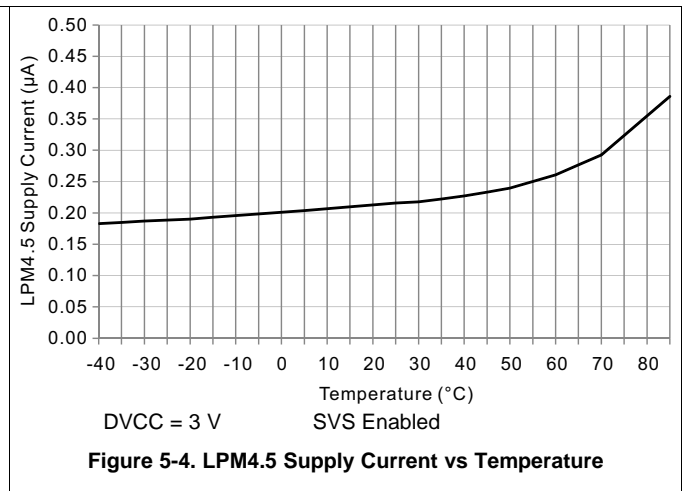
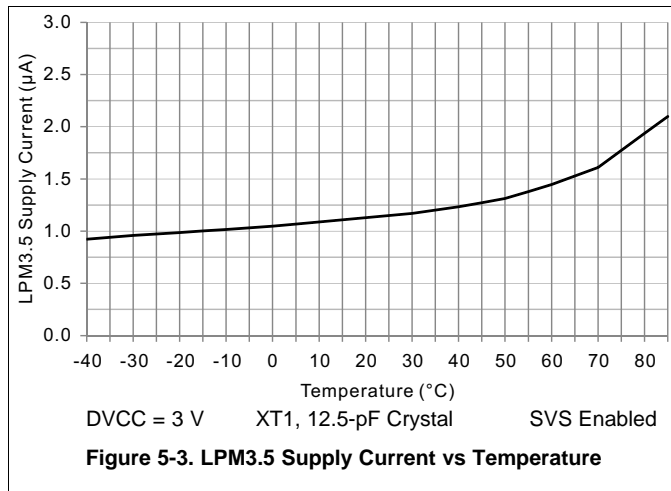

5.11 Typical Characteristics - Current Consumption Per Module

MODULE	TEST CONDITIONS	REFERENCE CLOCK	MIN	TYP	MAX	UNIT
Timer_B	SMCLK = 8 Hz, MC = 10	Module input clock		5		μA/MHz
eUSCI_A	UART mode	Module input clock		7		μA/MHz
eUSCI_A	SPI mode	Module input clock		5		μA/MHz
RTC		32 kHz		85		nA
CRC	From start to end of operation	MCLK		8.5		μA/MHz

5.12 Thermal Resistance Characteristics

PARAMETERS		VALUE	UNIT
R θ _{JA}	Junction-to-ambient thermal resistance, still air ⁽¹⁾	QFN 24 pin (RLL)	38.7
		TSSOP 16 pin (PW16)	106.5
R θ _{JC}	Junction-to-case (top) thermal resistance ⁽²⁾	QFN 24 pin (RLL)	39.5
		TSSOP 16 pin (PW16)	41.2
R θ _{JB}	Junction-to-board thermal resistance ⁽³⁾	QFN 24 pin (RLL)	8.6
		TSSOP 16 pin (PW16)	51.5

- (1) The junction-to-ambient thermal resistance under natural convection is obtained in a simulation on a JEDEC-standard, High-K board, as specified in JESD51-7, in an environment described in JESD51-2a.
- (2) The junction-to-case (top) thermal resistance is obtained by simulating a cold plate test on the package top. No specific JEDEC-standard test exists, but a close description can be found in the ANSI SEMI standard G30-88.
- (3) The junction-to-board thermal resistance is obtained by simulating in an environment with a ring cold plate fixture to control the PCB temperature, as described in JESD51-8.

5.13 Timing and Switching Characteristics

5.13.1 Power Supply Sequencing

Figure 5-5 shows the power cycle, SVS, and BOR reset conditions.

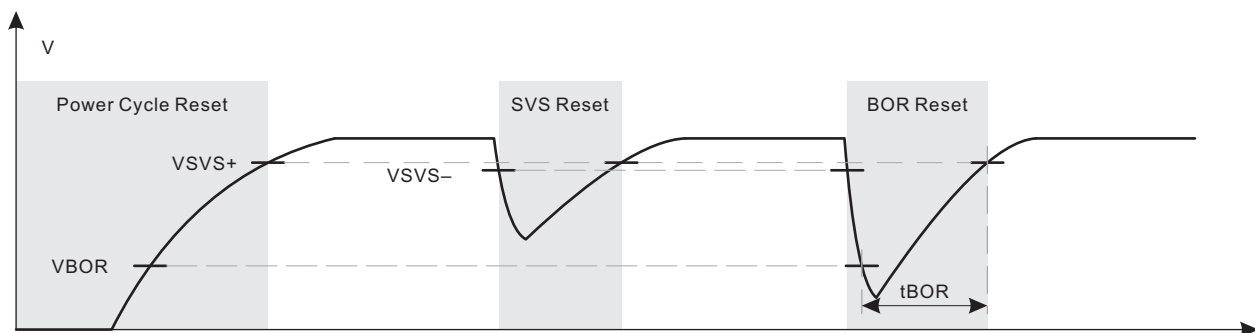

Figure 5-5. Power Cycle, SVS, and BOR Reset Conditions

Table 5-1 lists the characteristics of the SVS and BOR.

Table 5-1. PMM, SVS and BOR

over recommended ranges of supply voltage and operating free-air temperature (unless otherwise noted)

PARAMETER	TEST CONDITIONS	MIN	TYP	MAX	UNIT
V _{BOR, safe}	Safe BOR power-down level ⁽¹⁾	0.1			V
t _{BOR, safe}	Safe BOR reset delay ⁽²⁾	10			ms
I _{SVSH, AM}	SVS _H current consumption, active mode			1.5	μA
I _{SVSH, LPM}	SVS _H current consumption, low-power modes		240		nA
V _{SVSH-}	SVS _H power-down level	1.71	1.81	1.86	V
V _{SVSH+}	SVS _H power-up level	1.74	1.88	1.99	V
V _{SVSH_hys}	SVS _H hysteresis		80		mV
t _{PD, SVSH, AM}	SVS _H propagation delay, active mode			10	μs
t _{PD, SVSH, LPM}	SVS _H propagation delay, low-power modes			100	μs

(1) A safe BOR can only be correctly generated only if DV_{CC} must drop below this voltage before it rises.

(2) When an BOR occurs, a safe BOR can be correctly generated only if DV_{CC} is kept low longer than this period before it reaches V_{SVSH+}.

5.13.2 Reset Timing

Table 5-2 lists the wake-up time characteristics.

Table 5-2. Wake-Up Time From Low-Power Modes and Reset

over recommended ranges of supply voltage and operating free-air temperature (unless otherwise noted)

PARAMETER		TEST CONDITIONS	V _{CC}	MIN	TYP	MAX	UNIT
t _{WAKE-UP FRAM}	(Additional) wake-up time to activate the FRAM in AM if previously disabled through the FRAM controller or from an LPM if immediate activation is selected for wakeup ⁽¹⁾		3 V		10		μs
t _{WAKE-UP LPM0}	Wake-up time from LPM0 to active mode ⁽¹⁾		3 V			200 + 2.5 / f _{DCO}	ns
t _{WAKE-UP LPM3}	Wake-up time from LPM3 to active mode ⁽¹⁾		3 V		10		μs
t _{WAKE-UP LPM4}	Wake-up time from LPM4 to active mode ⁽²⁾		3 V		10		μs
t _{WAKE-UP LPM3.5}	Wake-up time from LPM3.5 to active mode ⁽²⁾		3 V		350		μs
t _{WAKE-UP LPM4.5}	Wake-up time from LPM4.5 to active mode ⁽²⁾	SVSHE = 1	3 V		350		μs
		SVSHE = 0	3 V		1		ms
t _{WAKE-UP-RESET}	Wake-up time from $\overline{\text{RST}}$ or BOR event to active mode ⁽²⁾		3 V		1		ms
t _{RESET}	Pulse duration required at $\overline{\text{RST}}$ /NMI pin to accept a reset				2		μs

- (1) The wake-up time is measured from the edge of an external wake-up signal (for example, port interrupt or wake-up event) to the first externally observable MCLK clock edge.
- (2) The wake-up time is measured from the edge of an external wake-up signal (for example, port interrupt or wake-up event) until the first instruction of the user program is executed.

5.13.3 Clock Specifications

Table 5-3 lists the characteristics of the XT1 in low-frequency mode.

Table 5-3. XT1 Crystal Oscillator (Low Frequency)

over recommended ranges of supply voltage and operating free-air temperature (unless otherwise noted)⁽¹⁾

PARAMETER		TEST CONDITIONS	V _{CC}	MIN	TYP	MAX	UNIT
f _{XT1, LF}	XT1 oscillator crystal, low frequency	LFXTBYPASS = 0			32768		Hz
DC _{XT1, LF}	XT1 oscillator LF duty cycle	Measured at MCLK, f _{LFXT} = 32768 Hz		30%		70%	
f _{XT1, SW}	XT1 oscillator logic-level square-wave input frequency	LFXTBYPASS = 1 ⁽²⁾ ⁽³⁾			32768		Hz
DC _{XT1, SW}	LFXT oscillator logic-level square-wave input duty cycle	LFXTBYPASS = 1		40%		60%	
OA _{LFXT}	Oscillation allowance for LF crystals ⁽⁴⁾	LFXTBYPASS = 0, LFXTDRIVE = {3}, f _{LFXT} = 32768 Hz, C _{L,eff} = 12.5 pF			200		kΩ
C _{L,eff}	Integrated effective load capacitance ⁽⁵⁾	See ⁽⁶⁾			1		pF
t _{START, LFXT}	Start-up time ⁽⁷⁾	f _{OSC} = 32768 Hz LFXTBYPASS = 0, LFXTDRIVE = {3}, T _A = 25°C, C _{L,eff} = 12.5 pF			1000		ms
f _{Fault, LFXT}	Oscillator fault frequency ⁽⁸⁾	XTS = 0 ⁽⁹⁾		0		3500	Hz

- (1) To improve EMI on the LFXT oscillator, observe the following guidelines:
- Keep the trace between the device and the crystal as short as possible.
 - Design a good ground plane around the oscillator pins.
 - Prevent crosstalk from other clock or data lines into oscillator pins XIN and XOUT.
 - Avoid running PCB traces underneath or adjacent to the XIN and XOUT pins.
 - Use assembly materials and processes that avoid any parasitic load on the oscillator XIN and XOUT pins.
 - If conformal coating is used, make sure that it does not induce capacitive or resistive leakage between the oscillator pins.
- (2) When LFXTBYPASS is set, LFXT circuits are automatically powered down. Input signal is a digital square wave with parametrics defined in the Schmitt-trigger inputs section of this data sheet. Duty cycle requirements are defined by DC_{LFXT, SW}.
- (3) Maximum frequency of operation of the entire device cannot be exceeded.
- (4) Oscillation allowance is based on a safety factor of 5 for recommended crystals. The oscillation allowance is a function of the LFXTDRIVE settings and the effective load. In general, comparable oscillator allowance can be achieved based on the following guidelines, but should be evaluated based on the actual crystal selected for the application:
- For LFXTDRIVE = {0}, C_{L,eff} = 3.7 pF.
 - For LFXTDRIVE = {1}, 6 pF ≤ C_{L,eff} ≤ 9 pF.
 - For LFXTDRIVE = {2}, 6 pF ≤ C_{L,eff} ≤ 10 pF.
 - For LFXTDRIVE = {3}, 6 pF ≤ C_{L,eff} ≤ 12 pF.
- (5) Includes parasitic bond and package capacitance (approximately 2 pF per pin).
- (6) Requires external capacitors at both terminals. Values are specified by crystal manufacturers.
- (7) Includes start-up counter of 1024 clock cycles.
- (8) Frequencies above the MAX specification do not set the fault flag. Frequencies in between the MIN and MAX specification may set the flag. A static condition or stuck at fault condition sets the flag.
- (9) Measured with logic-level input frequency but also applies to operation with crystals.

Table 5-4 lists the frequency characteristics of the DCO FLL.

Table 5-4. DCO FLL, Frequency

Over recommended operating free-air temperature (unless otherwise noted)

PARAMETER		TEST CONDITIONS	V _{CC}	MIN	TYP	MAX	UNIT
f _{DCO, FLL}	FLL lock frequency, 16 MHz, 25°C	Measured at MCLK, internal trimmed REFO as reference	3.0 V	-1.0%		1.0%	
	FLL lock frequency, 16 MHz, -40°C to 85°C		3.0 V	-2.0%		2.0%	
	FLL lock frequency, 16 MHz, -40°C to 85°C	Measured at MCLK, XT1 crystal as reference	3.0 V	-0.5%		0.5%	
f _{DUTY}	Duty cycle	Measured at MCLK, XT1 crystal as reference	3.0 V	40%	50%	60%	
Jitter _{CC}	Cycle-to-cycle jitter, 16 MHz		3.0 V		0.25%		
Jitter _{long}	Long term Jitter, 16 MHz		3.0 V		0.022%		
t _{FLL, lock}	FLL lock time		3.0 V		245		ms

Table 5-5 lists the frequency characteristics of the DCO.

Table 5-5. DCO Frequency

Over recommended operating free-air temperature (unless otherwise noted) (see Figure 5-6)

PARAMETER		TEST CONDITIONS	V _{CC}	MIN	TYP	MAX	UNIT
f _{DCO, 16 MHz} ⁽¹⁾	DCO frequency, 16 MHz	DCORSEL = 101b, DISMOD = 1b, DCOFTRIM = 000b, DCO = 0	3.0 V		7.8		MHz
		DCORSEL = 101b, DISMOD = 1b, DCOFTRIM = 000b, DCO = 511			12.5		
		DCORSEL = 101b, DISMOD = 1b, DCOFTRIM = 111b, DCO = 0			18.0		
		DCORSEL = 101b, DISMOD = 1b, DCOFTRIM = 111b, DCO = 511			30.0		
f _{DCO, 12 MHz} ⁽¹⁾	DCO frequency, 12 MHz	DCORSEL = 100b, DISMOD = 1b, DCOFTRIM = 000b, DCO = 0	3.0 V		6.0		MHz
		DCORSEL = 100b, DISMOD = 1b, DCOFTRIM = 000b, DCO = 511			9.5		
		DCORSEL = 100b, DISMOD = 1b, DCOFTRIM = 111b, DCO = 0			13.5		
		DCORSEL = 100b, DISMOD = 1b, DCOFTRIM = 111b, DCO = 511			22.0		
f _{DCO, 8 MHz} ⁽¹⁾	DCO frequency, 8 MHz	DCORSEL = 011b, DISMOD = 1b, DCOFTRIM = 000b, DCO = 0	3.0 V		3.8		MHz
		DCORSEL = 011b, DISMOD = 1b, DCOFTRIM = 000b, DCO = 511			6.5		
		DCORSEL = 011b, DISMOD = 1b, DCOFTRIM = 111b, DCO = 0			9.5		
		DCORSEL = 011b, DISMOD = 1b, DCOFTRIM = 111b, DCO = 511			16.0		
f _{DCO, 4 MHz} ⁽¹⁾	DCO frequency, 4 MHz	DCORSEL = 010b, DISMOD = 1b, DCOFTRIM = 000b, DCO = 0	3.0 V		2.0		MHz
		DCORSEL = 010b, DISMOD = 1b, DCOFTRIM = 000b, DCO = 511			3.2		
		DCORSEL = 010b, DISMOD = 1b, DCOFTRIM = 111b, DCO = 0			4.8		
		DCORSEL = 010b, DISMOD = 1b, DCOFTRIM = 111b, DCO = 511			8.0		

(1) This frequency reflects the achievable frequency range when FLL is either enabled or disabled.

Table 5-5. DCO Frequency (continued)

Over recommended operating free-air temperature (unless otherwise noted) (see Figure 5-6)

PARAMETER	TEST CONDITIONS	V _{CC}	MIN	TYP	MAX	UNIT
f _{DCO, 2 MHz} ⁽¹⁾ DCO frequency, 2 MHz	DCORSEL = 001b, DISMOD = 1b, DCOFTRIM = 000b, DCO = 0	3.0 V		1.0		MHz
	DCORSEL = 001b, DISMOD = 1b, DCOFTRIM = 000b, DCO = 511			1.7		
	DCORSEL = 001b, DISMOD = 1b, DCOFTRIM = 111b, DCO = 0			2.5		
	DCORSEL = 001b, DISMOD = 1b, DCOFTRIM = 111b, DCO = 511			4.2		
f _{DCO, 1 MHz} ⁽¹⁾ DCO frequency, 1 MHz	DCORSEL = 000b, DISMOD = 1b, DCOFTRIM = 000b, DCO = 0	3.0 V		0.5		MHz
	DCORSEL = 000b, DISMOD = 1b, DCOFTRIM = 000b, DCO = 511			0.85		
	DCORSEL = 000b, DISMOD = 1b, DCOFTRIM = 111b, DCO = 0			1.2		
	DCORSEL = 000b, DISMOD = 1b, DCOFTRIM = 111b, DCO = 511			2.1		

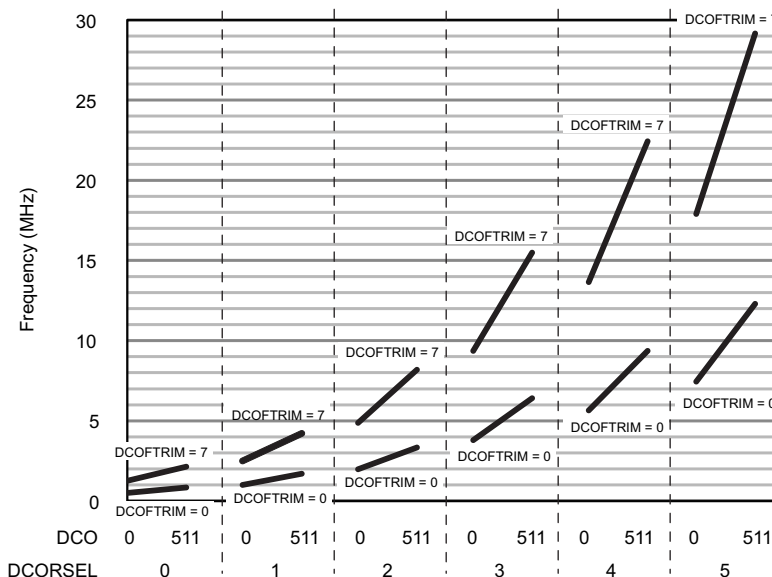

Figure 5-6. Typical DCO Frequency

Table 5-6 lists the characteristics of the REFO.

Table 5-6. REFO

Over recommended operating free-air temperature (unless otherwise noted)

PARAMETER	TEST CONDITIONS	V _{CC}	MIN	TYP	MAX	UNIT
I _{REFO}	REFO oscillator current consumption	T _A = 25°C		15		μA
f _{REFO}	REFO calibrated frequency	Measured at MCLK		32768		Hz
	REFO absolute calibrated tolerance	–40°C to 85°C	1.8 V to 3.6 V	–3.5%	+3.5%	
df _{REFO} /dT	REFO frequency temperature drift	Measured at MCLK ⁽¹⁾	3.0 V	0.01		%/°C
df _{REFO} /dV _{CC}	REFO frequency supply voltage drift	Measured at MCLK at 25°C ⁽²⁾	1.8 V to 3.6 V	1		%/V
f _{DC}	REFO duty cycle	Measured at MCLK	1.8 V to 3.6 V	40%	50%	60%
t _{START}	REFO start-up time	40% to 60% duty cycle		50		μs

(1) Calculated using the box method: (MAX(–40°C to 85°C) – MIN(–40°C to 85°C)) / MIN(–40°C to 85°C) / (85°C – (–40°C))

(2) Calculated using the box method: (MAX(1.8 V to 3.6 V) – MIN(1.8 V to 3.6 V)) / MIN(1.8 V to 3.6 V) / (3.6 V – 1.8 V)

Table 5-7 lists the characteristics of the VLO.

Table 5-7. Internal Very-Low-Power Low-Frequency Oscillator (VLO)

over recommended ranges of supply voltage and operating free-air temperature (unless otherwise noted)

PARAMETER		TEST CONDITIONS	V _{CC}	MIN	TYP	MAX	UNIT
f _{VLO}	VLO frequency	Measured at MCLK	3.0 V		10		kHz
df _{VLO} /dT	VLO frequency temperature drift	Measured at MCLK ⁽¹⁾	3.0 V		0.5		%/°C
df _{VLO} /dV _{CC}	VLO frequency supply voltage drift	Measured at MCLK ⁽²⁾	1.8 V to 3.6 V		4		%/V
f	Duty cycle	Measured at MCLK	3.0 V		50%		

(1) Calculated using the box method: (MAX(−40°C to 85°C) – MIN(−40°C to 85°C)) / MIN(−40°C to 85°C) / (85°C – (−40°C))

(2) Calculated using the box method: (MAX(1.8 V to 3.6 V) – MIN(1.8 V to 3.6 V)) / MIN(1.8 V to 3.6 V) / (3.6 V – 1.8 V)

NOTE

The VLO clock frequency is reduced by 15% (typical) when the device switches from active mode to LPM3 or LPM4, because the reference changes. This lower frequency is not a violation of the VLO specifications (see Table 5-7).

Table 5-8 lists the characteristics of the MODOSC.

Table 5-8. Module Oscillator (MODOSC)

over recommended ranges of supply voltage and operating free-air temperature (unless otherwise noted)

PARAMETER		TEST CONDITIONS	V _{CC}	MIN	TYP	MAX	UNIT
f _{MODOSC}	MODOSC frequency		3.0 V	3.8	4.8	5.8	MHz
f _{MODOSC} /dT	MODOSC frequency temperature drift		3.0 V		0.102		%/°C
f _{MODOSC} /dV _{CC}	MODOSC frequency supply voltage drift		1.8 V to 3.6 V		2.29		%/V
f _{MODOSC,DC}	Duty cycle		3.0 V	40%	50%	60%	

5.13.4 Digital I/Os

Table 5-9 lists the characteristics of the digital inputs.

Table 5-9. Digital Inputs

over recommended ranges of supply voltage and operating free-air temperature (unless otherwise noted)

PARAMETER		TEST CONDITIONS	V _{CC}	MIN	TYP	MAX	UNIT
V _{IT+}	Positive-going input threshold voltage		2 V	0.90		1.50	V
			3 V	1.35		2.25	
V _{IT−}	Negative-going input threshold voltage		2 V	0.50		1.10	V
			3 V	0.75		1.65	
V _{hys}	Input voltage hysteresis (V _{IT+} – V _{IT−})		2 V	0.3		0.8	V
			3 V	0.4		1.2	
R _{Pull}	Pullup or pulldown resistor	For pullup: V _{IN} = V _{SS} For pulldown: V _{IN} = V _{CC}		20	35	50	kΩ
C _{I,dig}	Input capacitance, digital only port pins	V _{IN} = V _{SS} or V _{CC}			3		pF
C _{I,ana}	Input capacitance, port pins with shared analog functions	V _{IN} = V _{SS} or V _{CC}			5		pF
I _{lkg(Px.y)}	High-impedance leakage current ⁽¹⁾⁽²⁾		2 V, 3 V	−20		+20	nA

(1) The leakage current is measured with V_{SS} or V_{CC} applied to the corresponding pins, unless otherwise noted.

(2) The leakage of the digital port pins is measured individually. The port pin is selected for input and the pullup/pulldown resistor is disabled.

Table 5-10 lists the characteristics of the digital outputs.

Table 5-10. Digital Outputs

over recommended ranges of supply voltage and operating free-air temperature (unless otherwise noted)

PARAMETER		TEST CONDITIONS	V _{CC}	MIN	TYP	MAX	UNIT
V _{OH}	High-level output voltage (also see Figure 5-9 and Figure 5-10)	I _(OHmax) = -3 mA ⁽¹⁾	2.0 V	1.4		2.0	V
		I _(OHmax) = -5 mA ⁽¹⁾	3.0 V	2.4		3.0	
V _{OL}	Low-level output voltage (also see Figure 5-7 and Figure 5-8)	I _(OLmax) = 3 mA ⁽¹⁾	2.0 V	0.0		0.60	V
		I _(OLmax) = 5 mA ⁽¹⁾	3.0 V	0.0		0.60	
f _{Port_CLK}	Clock output frequency	C _L = 20 pF ⁽²⁾	2.0 V	16			MHz
			3.0 V	16			
t _{rise,dig}	Port output rise time, digital only port pins	C _L = 20 pF	2.0 V		10		ns
			3.0 V		7		
t _{fall,dig}	Port output fall time, digital only port pins	C _L = 20 pF	2.0 V		10		ns
			3.0 V		5		

- (1) The maximum total current, I_(OHmax) and I_(OLmax), for all outputs combined should not exceed ±48 mA to hold the maximum voltage drop specified.
- (2) The port can output frequencies at least up to the specified limit and might support higher frequencies.

5.13.4.1 Digital I/O Typical Characteristics

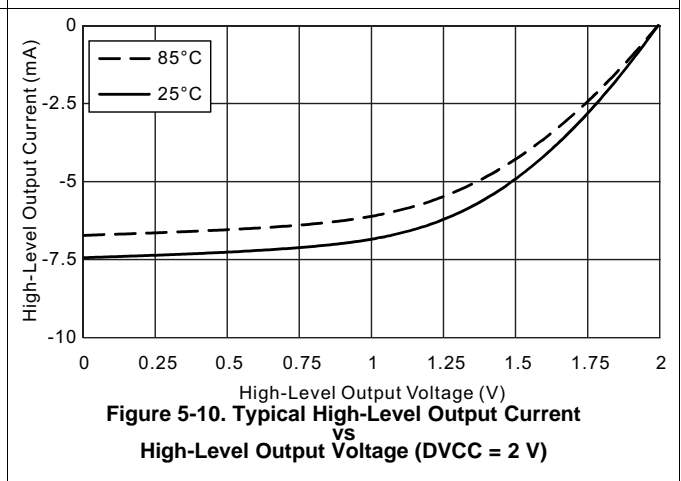
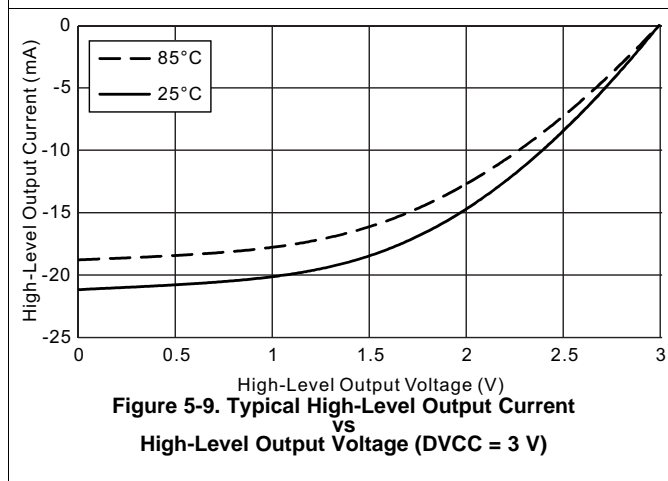
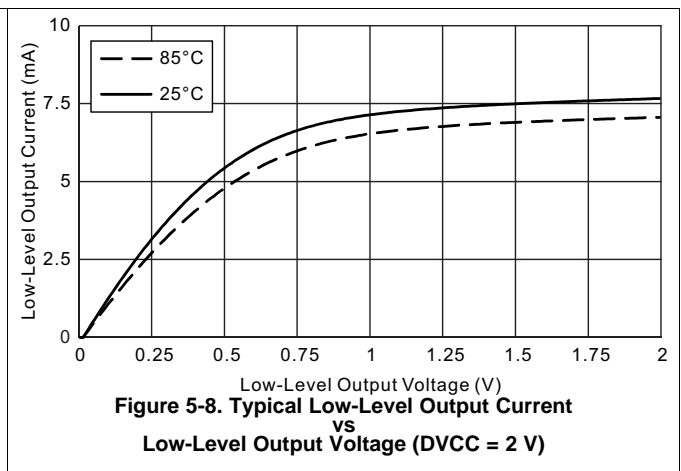
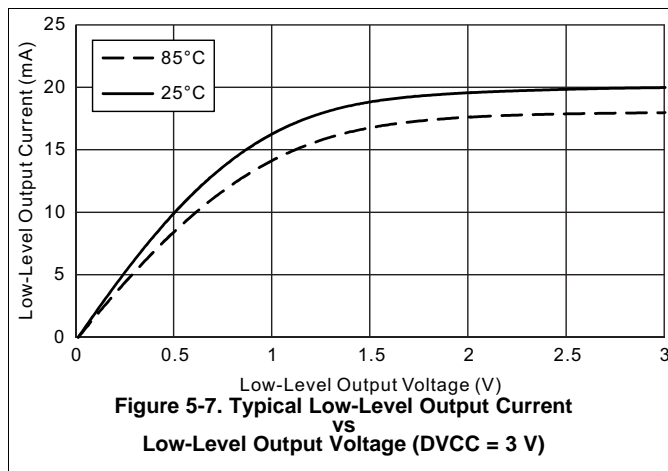

5.13.5 VREF+ Built-in Reference

Table 5-11 lists the characteristics of the VREF+.

Table 5-11. VREF+ Characteristics

over recommended ranges of supply voltage and operating free-air temperature (unless otherwise noted)

PARAMETER		TEST CONDITIONS	V _{CC}	MIN	TYP	MAX	UNIT
V _{REF+}	Positive built-in reference voltage	EXTREFEN = 1 with 1-mA load current	2.0 V, 3.0 V	1.158	1.2	1.242	V
T _{CREF+}	Temperature coefficient of built-in reference voltage	EXTREFEN = 1 with 1-mA load current			30		μV/°C

5.13.6 Timer_B

Table 5-12 lists the supported clock frequencies of Timer_B.

Table 5-12. Timer_B Clock Frequency

over recommended ranges of supply voltage and operating free-air temperature (unless otherwise noted)

PARAMETER		TEST CONDITIONS	V _{CC}	MIN	TYP	MAX	UNIT
f _{TB}	Timer_B input clock frequency	Internal: SMCLK or ACLK External: TBCLK Duty cycle = 50% ±10%	2.0 V, 3.0 V			16	MHz

5.13.7 eUSCI

Table 5-13 lists the clock frequency characteristics of the eUSCI in UART mode.

Table 5-13. eUSCI (UART Mode) Clock Frequency

over recommended ranges of supply voltage and operating free-air temperature (unless otherwise noted)

PARAMETER		TEST CONDITIONS	V _{CC}	MIN	TYP	MAX	UNIT
f _{eUSCI}	eUSCI input clock frequency	Internal: SMCLK or MODCLK External: UCLK Duty cycle = 50% ±10%	2.0 V, 3.0 V			16	MHz
f _{BITCLK}	BITCLK clock frequency (equals baud rate in Mbaud)		2.0 V, 3.0 V			5	MHz

Table 5-14 lists the switching characteristics of the eUSCI in UART mode.

Table 5-14. eUSCI (UART Mode) Switching Characteristics

over recommended ranges of supply voltage and operating free-air temperature (unless otherwise noted)

PARAMETER		TEST CONDITIONS	V _{CC}	MIN	TYP	MAX	UNIT
t _t	UART receive deglitch time ⁽¹⁾	UCGLITx = 0	2.0 V, 3.0 V		12		ns
		UCGLITx = 1			40		
		UCGLITx = 2			68		
		UCGLITx = 3			110		

- (1) Pulses on the UART receive input (UCxRX) shorter than the UART receive deglitch time are suppressed. To ensure that pulses are correctly recognized their width should exceed the maximum specification of the deglitch time.

Table 5-15 lists the clock frequency characteristics of the eUSCI in SPI master mode.

Table 5-15. eUSCI (SPI Master Mode) Clock Frequency

over recommended ranges of supply voltage and operating free-air temperature (unless otherwise noted)

PARAMETER		CONDITIONS	V _{CC}	MIN	TYP	MAX	UNIT
f _{eUSCI}	eUSCI input clock frequency	Internal: SMCLK or MODCLK Duty cycle = 50% ±10%				8	MHz

Table 5-16 lists the switching characteristics of the eUSCI in SPI master mode.

Table 5-16. eUSCI (SPI Master Mode) Switching Characteristics

over recommended ranges of supply voltage and operating free-air temperature (unless otherwise noted)⁽¹⁾

PARAMETER		TEST CONDITIONS	V _{CC}	MIN	MAX	UNIT
t _{STE,LEAD}	STE lead time, STE active to clock	UCSTEM = 1, UCMODEx = 01 or 10	3.0 V	1		UCxCLK cycles
t _{STE,LAG}	STE lag time, Last clock to STE inactive	UCSTEM = 1, UCMODEx = 01 or 10	3.0 V	1		UCxCLK cycles
t _{SU,MI}	SOMI input data setup time		2.0 V	53		ns
			3.0 V	35		
t _{HD,MI}	SOMI input data hold time		2.0 V	0		ns
			3.0 V	0		
t _{VALID,MO}	SIMO output data valid time ⁽²⁾	UCLK edge to SIMO valid, C _L = 20 pF	2.0 V		20	ns
			3.0 V		20	
t _{HD,MO}	SIMO output data hold time ⁽³⁾	C _L = 20 pF	2.0 V	0		ns
			3.0 V	0		

- (1) $f_{UCxCLK} = 1/2(t_{LO/Hi})$ with $t_{LO/Hi} = \max(t_{VALID,MO(eUSCI)} + t_{SU,SI(Slave)}, t_{SU,MI(eUSCI)} + t_{VALID,SO(Slave)})$. For the slave parameters $t_{SU,SI(Slave)}$ and $t_{VALID,SO(Slave)}$ see the SPI parameters of the attached slave.
- (2) Specifies the time to drive the next valid data to the SIMO output after the output changing UCLK clock edge. See the timing diagrams in Figure 5-11 and Figure 5-12.
- (3) Specifies how long data on the SIMO output is valid after the output changing UCLK clock edge. Negative values indicate that the data on the SIMO output can become invalid before the output changing clock edge observed on UCLK. See the timing diagrams in Figure 5-11 and Figure 5-12.

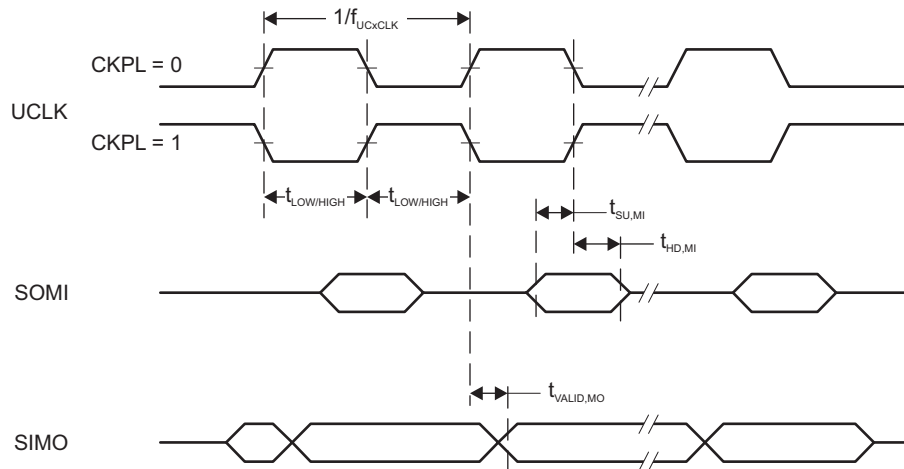

Figure 5-11. SPI Master Mode, CKPH = 0

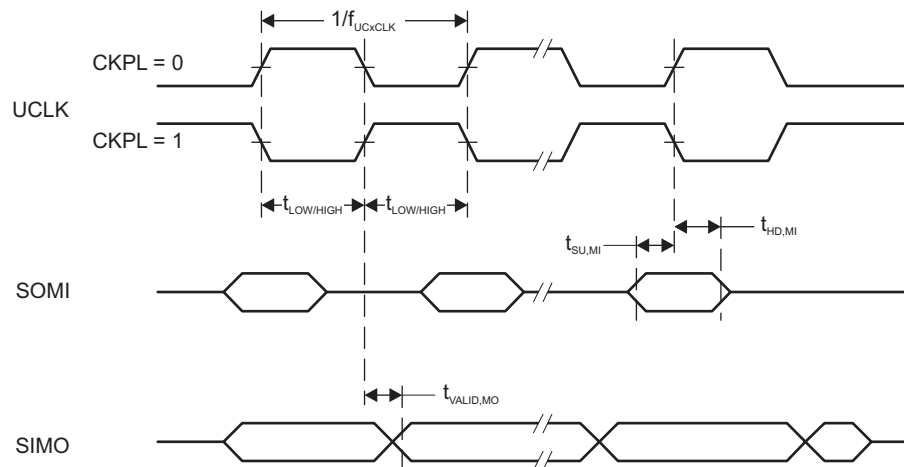

Figure 5-12. SPI Master Mode, CKPH = 1

Table 5-17 lists the switching characteristics of the eUSCI in SPI slave mode.

Table 5-17. eUSCI (SPI Slave Mode) Switching Characteristics

over recommended ranges of supply voltage and operating free-air temperature (unless otherwise noted)⁽¹⁾

PARAMETER		TEST CONDITIONS	V _{CC}	MIN	MAX	UNIT
t _{STE,LEAD}	STE lead time, STE active to clock		2.0 V	55		ns
			3.0 V	45		
t _{STE,LAG}	STE lag time, last clock to STE inactive		2.0 V	20		ns
			3.0 V	20		
t _{STE,ACC}	STE access time, STE active to SOMI data out		2.0 V		65	ns
			3.0 V		40	
t _{STE,DIS}	STE disable time, STE inactive to SOMI high impedance		2.0 V		50	ns
			3.0 V		35	
t _{SU,SI}	SIMO input data setup time		2.0 V	10		ns
			3.0 V	8		
t _{HD,SI}	SIMO input data hold time		2.0 V	12		ns
			3.0 V	12		
t _{VALID,SO}	SOMI output data valid time ⁽²⁾	UCLK edge to SOMI valid, C _L = 20 pF	2.0 V		68	ns
			3.0 V		42	
t _{HD,SO}	SOMI output data hold time ⁽³⁾	C _L = 20 pF	2.0 V	5		ns
			3.0 V	5		

(1) $f_{UCxCLK} = 1/2t_{LO/HI}$ with $t_{LO/HI} \geq \max(t_{VALID,MO(Master)} + t_{SU,SI(eUSCI)}, t_{SU,MI(Master)} + t_{VALID,SO(eUSCI)})$.

For the master parameters $t_{SU,MI(Master)}$ and $t_{VALID,MO(Master)}$ see the SPI parameters of the attached slave.

(2) Specifies the time to drive the next valid data to the SOMI output after the output changing UCLK clock edge. See the timing diagrams in [Figure 5-13](#) and [Figure 5-14](#).

(3) Specifies how long data on the SOMI output is valid after the output changing UCLK clock edge. See the timing diagrams in [Figure 5-13](#) and [Figure 5-14](#).

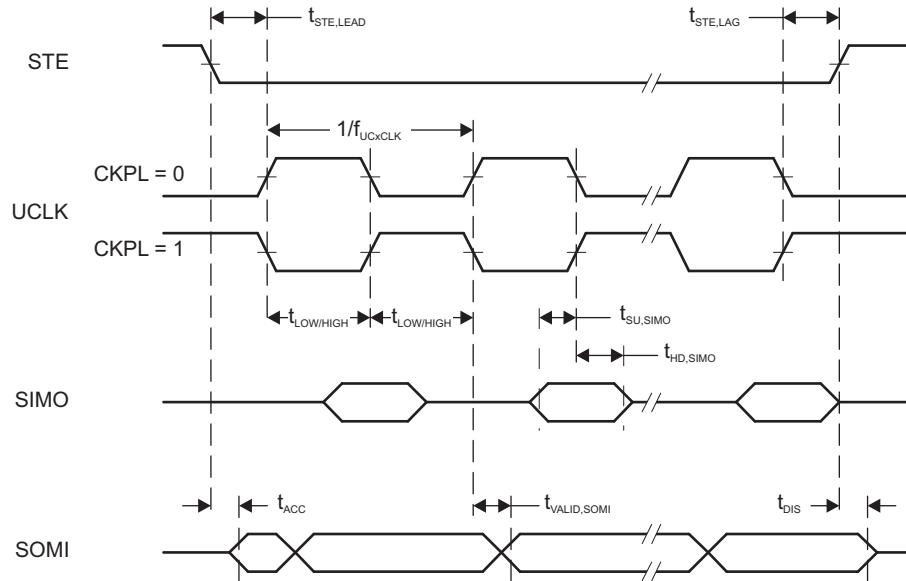

Figure 5-13. SPI Slave Mode, CKPH = 0

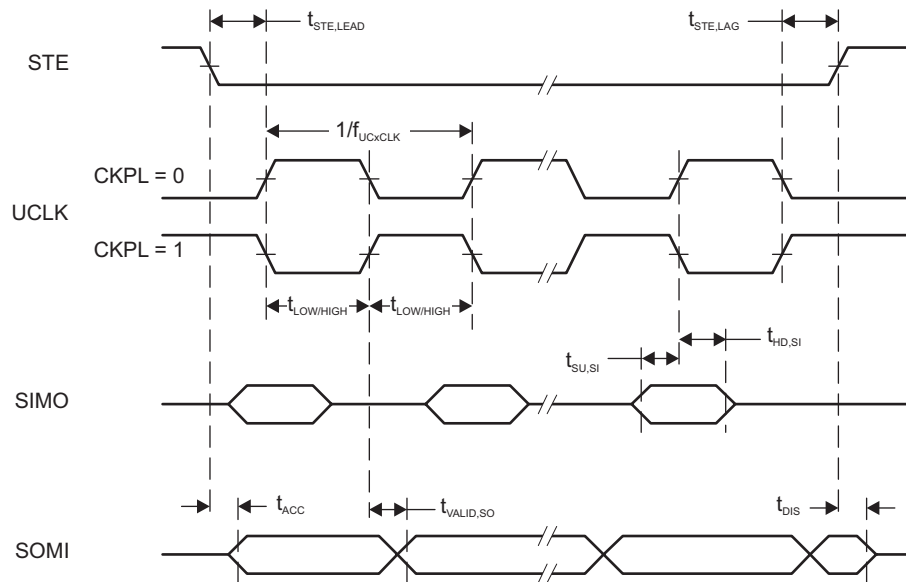

Figure 5-14. SPI Slave Mode, CKPH = 1

5.13.8 ADC

Table 5-18 lists the input conditions of the ADC.

Table 5-18. ADC, Power Supply and Input Range Conditions

Over operating free-air temperature range (unless otherwise noted)

PARAMETER		TEST CONDITIONS	V _{CC}	MIN	TYP	MAX	UNIT
DV _{CC}	ADC supply voltage			2.0		3.6	V
V _(Ax)	Analog input voltage range	All ADC pins		0		DV _{CC}	V
I _{ADC}	Operating supply current into DVCC terminal, reference current not included, repeat-single-channel mode	f _{ADCCLK} = 5 MHz, ADCON = 1, REFON = 0, SHT0 = 0, SHT1 = 0, ADCDIV = 0, ADCCONSEQx = 10b	2 V		185		μA
			3 V		207		
C _I	Input capacitance	Only one terminal Ax can be selected at one time from the pad to the ADC capacitor array, including wiring and pad	2.2 V		2.5	3.5	pF
R _I	Input MUX ON resistance	DV _{CC} = 2 V, 0 V = V _{Ax} = DV _{CC}				2	kΩ

Table 5-19 lists the timing parameters of the ADC.

Table 5-19. ADC, 10-Bit Timing Parameters

Over operating free-air temperature range (unless otherwise noted)

PARAMETER		TEST CONDITIONS	V _{CC}	MIN	TYP	MAX	UNIT
f _{ADCCLK}		For specified performance of ADC linearity parameters	2 V to 3.6 V	0.45	5	5.5	MHz
f _{ADCOSC}	Internal ADC oscillator (MODOSC)	ADCDIV = 0, f _{ADCCLK} = f _{ADCOSC}	2 V to 3.6 V	3.8	4.8	5.8	MHz
t _{CONVERT}	Conversion time	REFON = 0, Internal oscillator, 10 ADCCLK cycles, 10-bit mode, f _{ADCOSC} = 4.5 MHz to 5.5 MHz	2 V to 3.6 V	2.18		2.67	μs
t _{ADCON}	Turnon settling time of the ADC	The error in a conversion started after t _{ADCON} is less than ±0.5 LSB. Reference and input signal are already settled.				100	ns
t _{Sample}	Sampling time	R _S = 1000 Ω, R _I = 36000 Ω, C _I = 3.5 pF. Approximately 8 Tau (t) are required for an error of less than ±0.5 LSB.	2 V	1.5			μs
			3 V	2.0			

Table 5-20 lists the linearity parameters of the ADC.

Table 5-20. ADC, 10-Bit Linearity Parameters

Over operating free-air temperature range (unless otherwise noted)

PARAMETER		TEST CONDITIONS	V _{CC}	MIN	TYP	MAX	UNIT
E _I	Integral linearity error (10-bit mode)	V _{ref+} reference	2.4 V to 3.6 V	-2		2	LSB
	Integral linearity error (8-bit mode)		2.0 V to 3.6 V	-2		2	
E _D	Differential linearity error (10-bit mode)	V _{ref+} reference	2.4 V to 3.6 V	-1		1	LSB
	Differential linearity error (8-bit mode)		2.0 V to 3.6 V	-1		1	
E _O	Offset error (10-bit mode)	V _{ref+} reference	2.4 V to 3.6 V	-6.5		6.5	mV
	Offset error (8-bit mode)		2.0 V to 3.6 V	-6.5		6.5	
E _G	Gain error (10-bit mode)	V _{ref+} as reference	2.4 V to 3.6 V	-2.0		2.0	LSB
		Internal 1.5-V reference		-3.0%		3.0%	
	Gain error (8-bit mode)	V _{ref+} as reference	2.0 V to 3.6 V	-2.0		2.0	LSB
		Internal 1.5-V reference		-3.0%		3.0%	
E _T	Total unadjusted error (10-bit mode)	V _{ref+} as reference	2.4 V to 3.6 V	-2.0		2.0	LSB
		Internal 1.5-V reference		-3.0%		3.0%	
	Total unadjusted error (8-bit mode)	V _{ref+} as reference	2.0 V to 3.6 V	-2.0		2.0	LSB
		Internal 1.5-V reference		-3.0%		3.0%	
V _{SENSOR}	See ⁽¹⁾	ADCON = 1, INCH = 0Ch, T _A = 0°C	3.0 V		913		mV
TC _{SENSOR}	See ⁽²⁾	ADCON = 1, INCH = 0Ch	3.0 V		3.35		mV/°C
t _{SENSOR} (sample)	Sample time required if channel 12 is selected	ADCON = 1, INCH = 0Ch, Error of conversion result ≤1 LSB, AM and all LPMs above LPM3	3.0 V		30		μs
		ADCON = 1, INCH = 0Ch, Error of conversion result ≤1 LSB, LPM3	3.0 V		100		

- (1) The temperature sensor offset can vary significantly. TI recommends a single-point calibration to minimize the offset error of the built-in temperature sensor.
- (2) The device descriptor structure contains calibration values for 30°C ±3°C and 85°C ±3°C for each available reference voltage level. The sensor voltage can be computed as $V_{SENSE} = TC_{SENSOR} \times (\text{Temperature, } ^\circ\text{C}) + V_{SENSOR}$, where TC_{SENSOR} and V_{SENSOR} can be computed from the calibration values for higher accuracy.

5.13.9 Enhanced Comparator (eCOMP)

Table 5-21 lists the characteristics of the eCOMP.

Table 5-21. eCOMP

over recommended ranges of supply voltage and operating free-air temperature (unless otherwise noted)

PARAMETER		TEST CONDITIONS	V _{CC}	MIN	TYP	MAX	UNIT
V _{CC}	Supply voltage			2.0		3.6	V
V _{IC}	Common-mode input range			0		V _{CC}	V
V _{HYS}	DC input hysteresis	CPEN = 1, CPHSEL = 00	2.0 V to 3.6 V		0		mV
		CPEN = 1, CPHSEL = 01		10			
		CPEN = 1, CPHSEL = 10		20			
		CPEN = 1, CPHSEL = 11		30			
V _{OFFSET}	Input offset voltage	CPEN = 1, CPMSEL = 0, CPHSEL = 00	2.0 V to 3.6 V	-40	±5	-40	mV
		CPEN = 1, CPMSEL = 1, CPHSEL = 00		±10			
I _{COMP}	Quiescent current draw from V _{CC} , only comparator	V _{IC} = V _{CC} /2, CPEN = 1, CPMSEL = 0	2.0 V to 3.6 V		22	35	μA
		V _{IC} = V _{CC} /2, CPEN = 1, CPMSEL = 1		1.3	3.5		
I _{DAC}	Quiescent current draw from V _{CC} , only DAC	CPDACREFS = 0, CPEN = 0	2.0 V to 3.6 V		0.5		μA
C _{IN}	Input channel capacitance ⁽¹⁾		2.0 V to 3.6 V		1		pF
R _{IN}	Input channel series resistance	On (switch closed)	2.0 V to 3.6 V		10	20	kΩ
		Off (switch open)		50		MΩ	
t _{PD}	Propagation delay, response time	CPMSEL = 0, CPFLT = 0, Overdrive = 20 mV ⁽²⁾	2.0 V to 3.6 V			1	μs
		CPMSEL = 1, CPFLT = 0, Overdrive = 20 mV ⁽²⁾		2.4			
t _{EN_CP}	Comparator enable time	CPEN = 0→1, CPMSEL = 0, V+ and V- from pads, Overdrive = 20 mV ⁽²⁾	2.0 V to 3.6 V		9.3		μs
		CPEN = 0→1, CPMSEL = 1, V+ and V- from pads, Overdrive = 20 mV ⁽²⁾		12			
t _{EN_CP_DAC}	Comparator with reference DAC enable time	CPEN = 0→1, CPDACEN=0→1, CPMSEL = 0, CPDACREFS = 1, CPDACBUF1 = 0F, Overdrive = 20 mV ⁽²⁾	2.0 V to 3.6 V		9.3		μs
		CPEN = 0→1, CPDACEN=0→1, CPMSEL = 1, CPDACREFS = 1, CPDACBUF1 = 0F, Overdrive = 20 mV ⁽²⁾		113			
t _{FDLY}	Propagation delay with analog filter active	CPMSEL = 0, CPFLTDY = 00, Overdrive = 20 mV, ⁽²⁾ CPFLT = 1	2.0 V to 3.6 V		0.7		μs
		CPMSEL = 0, CPFLTDY = 01, Overdrive = 20 mV, ⁽²⁾ CPFLT = 1		1.1			
		CPMSEL = 0, CPFLTDY = 10, Overdrive = 20 mV, ⁽²⁾ CPFLT = 1		1.9			
		CPMSEL = 0, CPFLTDY = 11, Overdrive = 20 mV, ⁽²⁾ CPFLT = 1		3.7			
V _{CP_DAC}	Reference voltage for built-in 6-bit DAC	V _{IN} = reference into 6-bit DAC, DAC uses internal REF, n = 0 to 63	2.0 V to 3.6 V		V _{IN} × n / 64		V
		V _{IN} = reference into 6-bit DAC, DAC uses V _{CC} as REF, n = 0 to 63		V _{IN} × n / 64			
INL	Integral nonlinearity		2.0 V to 3.6 V	-0.5		+0.5	LSB
DNL	Differential nonlinearity		2.0 V to 3.6 V	-0.5		+0.5	LSB

(1) For the eCOMP C_{IN} model, see Figure 5-15.

(2) This is measured over the input offset.

Table 5-21. eCOMP (continued)

over recommended ranges of supply voltage and operating free-air temperature (unless otherwise noted)

PARAMETER	TEST CONDITIONS	V _{CC}	MIN	TYP	MAX	UNIT
Zero Scale		2.0 V to 3.6 V		0		LSB
I _{DACOFF} Leakage current		2.0 V to 3.6 V		5		nA

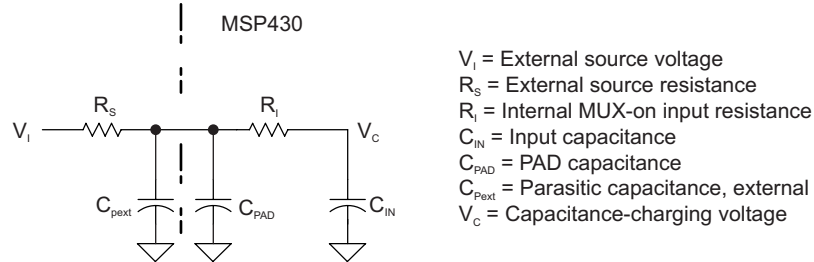

Figure 5-15. eCOMP Input Circuit

5.13.10 FRAM

Table 5-22 lists the characteristics of the FRAM.

Table 5-22. FRAM

over recommended ranges of supply voltage and operating free-air temperature (unless otherwise noted)

PARAMETER	TEST CONDITIONS	MIN	TYP	MAX	UNIT
Read and write endurance		10 ¹⁵			cycles
t _{Retention} Data retention duration	T _J = 25°C	100			years
	T _J = 70°C	40			
	T _J = 85°C	10			
I _{WRITE} Current to write into FRAM			I _{READ} ⁽¹⁾		nA
I _{ERASE} Erase current			n/a ⁽²⁾		
t _{WRITE} Write time			t _{READ} ⁽³⁾		ns
I _{READ}	Read time, NWAITSx = 0		1 / f _{SYSTEM} ⁽⁴⁾		ns
	Read time, NWAITSx = 1		2 / f _{SYSTEM} ⁽⁴⁾		ns

- (1) Writing to FRAM does not require a setup sequence or additional power when compared to reading from FRAM. The FRAM read current I_{READ} is included in the active mode current consumption I_{AM, FRAM}.
- (2) n/a = not applicable. FRAM does not require a special erase sequence.
- (3) Writing to FRAM is as fast as reading.
- (4) The maximum read (and write) speed is specified by f_{SYSTEM} using the appropriate wait state settings (NWAITSx).

5.13.11 Emulation and Debug

Table 5-23 lists the characteristics of the Spy-Bi-Wire interface.

Table 5-23. JTAG, Spy-Bi-Wire Interface

over recommended ranges of supply voltage and operating free-air temperature (unless otherwise noted) (see Figure 5-16)

PARAMETER		V _{CC}	MIN	TYP	MAX	UNIT
f _{SBW}	Spy-Bi-Wire input frequency	2.0 V, 3.0 V	0		8	MHz
t _{SBW,Low}	Spy-Bi-Wire low clock pulse duration	2.0 V, 3.0 V	0.028		15	µs
t _{SU,SBWTDIO}	SBWTDIO setup time (before falling edge of SBWTCK in TMS and TDI slot Spy-Bi-Wire)	2.0 V, 3.0 V	4			ns
t _{HD,SBWTDIO}	SBWTDIO hold time (after rising edge of SBWTCK in TMS and TDI slot Spy-Bi-Wire)	2.0 V, 3.0 V	19			ns
t _{Valid,SBWTDIO}	SBWTDIO data valid time (after falling edge of SBWTCK in TDO slot Spy-Bi-Wire)	2.0 V, 3.0 V			31	ns
t _{SBW, En}	Spy-Bi-Wire enable time (TEST high to acceptance of first clock edge) (1)	2.0 V, 3.0 V			110	µs
t _{SBW,Ret}	Spy-Bi-Wire return to normal operation time ⁽²⁾	2.0 V, 3.0 V	15		100	µs

- (1) Tools that access the Spy-Bi-Wire interface must wait for the t_{SBW,En} time after pulling the TEST/SBWTCK pin high before applying the first SBWTCK clock edge.
- (2) Maximum t_{SBW,Rst} time after pulling or releasing the TEST/SBWTCK pin low, the Spy-Bi-Wire pins revert from their Spy-Bi-Wire function to their application function. This time applies only if the Spy-Bi-Wire mode was selected.

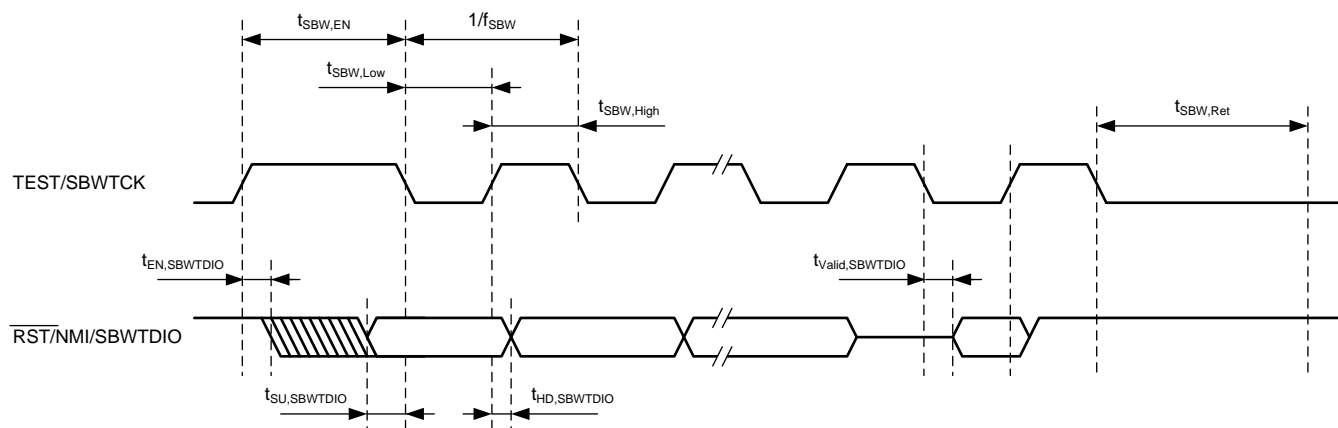

Figure 5-16. JTAG Spy-Bi-Wire Timing

Table 5-24 lists the characteristics of the 4-wire JTAG interface.

Table 5-24. JTAG, 4-Wire Interface

over recommended ranges of supply voltage and operating free-air temperature (unless otherwise noted) (see Figure 5-17)

PARAMETER		V _{CC}	MIN	TYP	MAX	UNIT
f _{TCK}	TCK input frequency ⁽¹⁾	2.0 V, 3.0 V	0		10	MHz
t _{TCK,Low}	TCK low clock pulse duration	2.0 V, 3.0 V	15			ns
t _{TCK,high}	TCK high clock pulse duration	2.0 V, 3.0 V	15			ns
t _{SU,TMS}	TMS setup time (before rising edge of TCK)	2.0 V, 3.0 V	11			ns
t _{HD,TMS}	TMS hold time (after rising edge of TCK)	2.0 V, 3.0 V	3			ns
t _{SU,TDI}	TDI setup time (before rising edge of TCK)	2.0 V, 3.0 V	13			ns
t _{HD,TDI}	TDI hold time (after rising edge of TCK)	2.0 V, 3.0 V	5			ns
t _{z-Valid,TDO}	TDO high impedance to valid output time (after falling edge of TCK)	2.0 V, 3.0 V			26	ns
t _{Valid,TDO}	TDO to new valid output time (after falling edge of TCK)	2.0 V, 3.0 V			26	ns
t _{Valid-Z,TDO}	TDO valid to high-impedance output time (after falling edge of TCK)	2.0 V, 3.0 V			26	ns
t _{JTAG,Ret}	JTAG return to normal operation time		15		100	μs
R _{internal}	Internal pulldown resistance on TEST	2.0 V, 3.0 V	20	35	50	kΩ

(1) Tools that access the Spy-Bi-Wire interface must wait for the t_{SBW,En} time after pulling the TEST/SBWTCK pin high before applying the first SBWTCK clock edge.

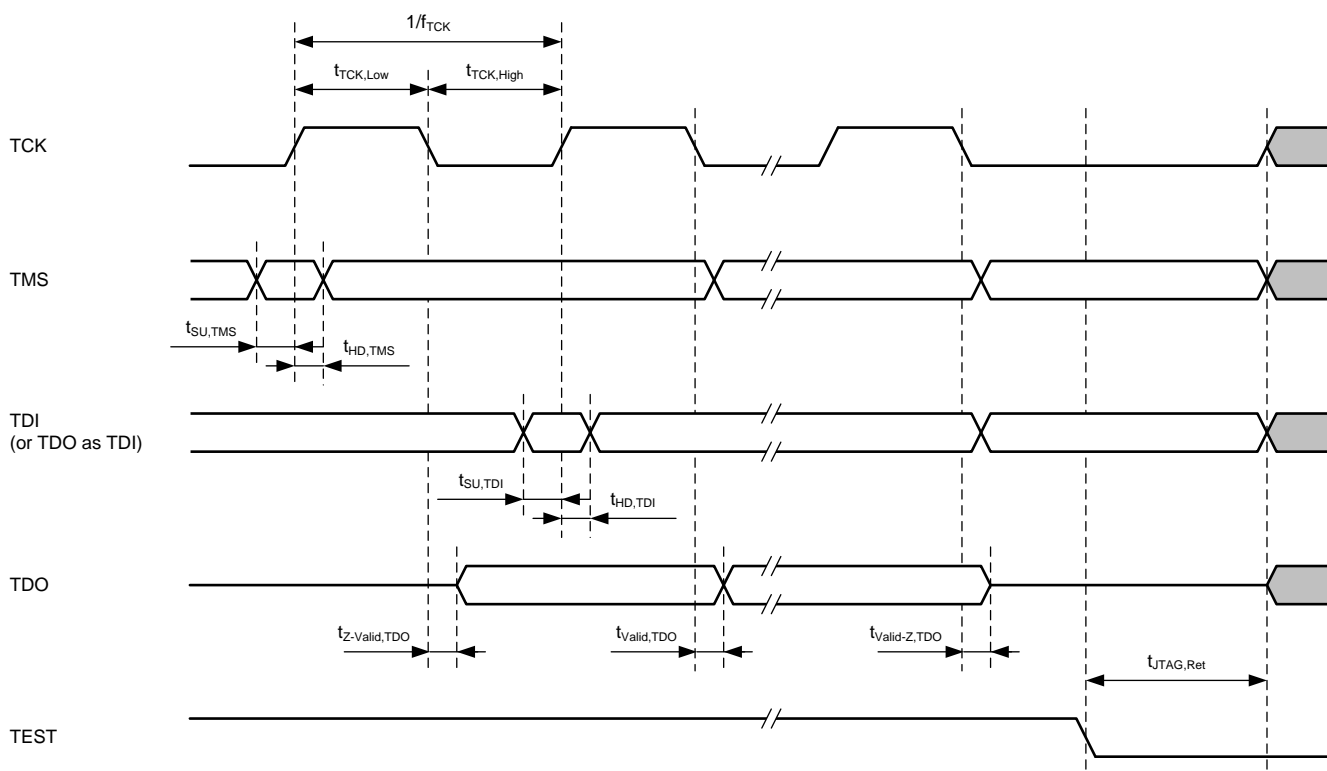

Figure 5-17. JTAG 4-Wire Timing

6 Detailed Description

6.1 Overview

The Texas Instruments MSP430FR211x family of ultra-low-power microcontrollers consists of several devices featuring different sets of peripherals. The architecture, combined with five low-power modes, is optimized to achieve extended battery life (for example, in portable measurement applications). The devices feature a powerful 16-bit RISC CPU, 16-bit register, and constant generators that contribute to maximum code efficiency.

The MSP430FR211x devices are microcontroller configurations with one Timer_B, eCOMP with built-in 6-bit DAC as an internal reference voltage, a high-performance 10-bit ADC, an eUSCI that supports UART and SPI, an RTC module with alarm capabilities, and up to 12 I/O pins.

6.2 CPU

The MSP430 CPU has a 16-bit RISC architecture that is highly transparent to the application. All operations, other than program-flow instructions, are performed as register operations in conjunction with seven addressing modes for source operand and four addressing modes for destination operand.

The CPU is integrated with 16 registers that provide reduced instruction execution time. The register-to-register operation execution time is one cycle of the CPU clock.

Four of the registers, R0 to R3, are dedicated as program counter (PC), stack pointer (SP), status register (SR), and constant generator (CG), respectively. The remaining registers are general-purpose registers.

Peripherals are connected to the CPU using data, address, and control buses. Peripherals can be managed with all instructions.

6.3 Operating Modes

The MSP430 has one active mode and several software selectable low-power modes of operation (see [Table 6-1](#)). An interrupt event can wake up the device from low-power mode LPM0, LPM3 or LPM4, service the request, and restore back to the low-power mode on return from the interrupt program. Low-power modes LPM3.5 and LPM4.5 disable the core supply to minimize power consumption.

NOTE

XT1CLK and VLOCLK can be active during LPM4 if requested by low-frequency peripherals.

Table 6-1. Operating Modes

MODE		AM	LPM0	LPM3	LPM4	LPM3.5	LPM4.5
		ACTIVE MODE	CPU OFF	STANDBY	OFF	ONLY RTC COUNTER	SHUTDOWN
Maximum System Clock		16 MHz	16 MHz	40 kHz	0	40 kHz	0
Power Consumption at 25°C, 3 V		120 µA/MHz	40 µA/MHz	1.5 µA	0.42 µA without SVS	0.66 µA	34 nA without SVS
Wake-up time		N/A	instant	10 µs	10 µs	150 µs	150 µs
Wake-up events		N/A	All	All	I/O	RTC Counter I/O	I/O
Power	Regulator	Full Regulation	Full Regulation	Partial Power Down	Partial Power Down	Partial Power Down	Power Down
	SVS	On	On	Optional	Optional	Optional	Optional
	Brown Out	On	On	On	On	On	On

Table 6-1. Operating Modes (continued)

MODE		AM	LPM0	LPM3	LPM4	LPM3.5	LPM4.5
		ACTIVE MODE	CPU OFF	STANDBY	OFF	ONLY RTC COUNTER	SHUTDOWN
Clock ⁽¹⁾	MCLK	Active	Off	Off	Off	Off	Off
	SMCLK	Optional	Optional	Off	Off	Off	Off
	FLL	Optional	Optional	Off	Off	Off	Off
	DCO	Optional	Optional	Off	Off	Off	Off
	MODCLK	Optional	Optional	Off	Off	Off	Off
	REFO	Optional	Optional	Optional	Off	Off	Off
	ACLK	Optional	Optional	Optional	Off	Off	Off
	XT1LFCLK	Optional	Optional	Optional	Off	Optional	Off
	VLOCLK	Optional	Optional	Optional	Off	Optional	Off
Core	CPU	On	Off	Off	Off	Off	Off
	FRAM	On	On	Off	Off	Off	Off
	RAM	On	On	On	On	Off	Off
	Backup Memory ⁽²⁾	On	On	On	On	On	Off
Peripherals	Timer_B3	Optional	Optional	Optional	Off	Off	Off
	WDT	Optional	Optional	Optional	Off	Off	Off
	eUSCI_A	Optional	Optional	Off	Off	Off	Off
	CRC	Optional	Optional	Off	Off	Off	Off
	ADC	Optional	Optional	Optional	Off	Off	Off
	eCOMP	Optional	Optional	Optional	Optional	Off	Off
	RTC Counter	Optional	Optional	Optional	Off	Optional	Off
I/O	General Digital Input/Output	On	Optional	State Held	State Held	State Held	State Held
	Capacitive Touch I/O	Optional	Optional	Optional	Off	Off	Off

(1) The status shown for LPM4 applies to internal clocks only

(2) Backup memory contains 32 bytes of register space in the peripheral memory. See [Table 6-18](#) and [Table 6-31](#) for its memory allocation.

6.4 Interrupt Vector Addresses

The interrupt vectors and the power-up start address are in the address range 0FFFFh to 0FF80h. The vector contains the 16-bit address of the appropriate interrupt-handler instruction sequence. [Table 6-2](#) summarizes the interrupts sources, flags, and vectors.

Table 6-2. Interrupt Sources, Flags, and Vectors

INTERRUPT SOURCE	INTERRUPT FLAG	SYSTEM INTERRUPT	WORD ADDRESS	PRIORITY
System Reset Power-up, Brownout, Supply Supervisor External Reset RST Watchdog Time-out, Key Violation FRAM uncorrectable bit error detection Software POR, BOR FLL unlock error	SVSHIFG PMMRSTIFG WDTIFG PMMPORIFG, PMMBORIFG SYSRSTIV FLLULPUC	Reset	FFFEh	63, Highest
System NMI Vacant Memory Access JTAG Mailbox FRAM access time error FRAM bit error detection	VMAIFG JMBINIFG, JMBOUTIFG CBDIFG, UBDIFG	(Non)maskable	FFFCh	62
User NMI External NMI Oscillator Fault	NMIIFG OFIFG	(Non)maskable	FFFAh	61
Timer0_B3	TB0CCR0 CCIFG0	Maskable	FFF8h	60
Timer0_B3	TB0CCR1 CCIFG1, TB0CCR2 CCIFG2, TB0IFG (TB0IV)	Maskable	FFF6h	59
RTC Counter	RTCIFG	Maskable	FFF4h	58
Watchdog Timer Interval mode	WDTIFG	Maskable	FFF2h	57
eUSCI_A0 Receive or Transmit	UCTXCFIFG, UCSTTIFG, UCRXIFG, UCTXIFG (UART mode) UCRXIFG, UCTXIFG (SPI mode) (UCA0IV))	Maskable	FFF0h	56
ADC	ADCIFG0, ADCINIFG, ADCLOIFG, ADCHIIFG, ADCTOVIFG, ADCOVIFG (ADCIV)	Maskable	FFEEh	55
P1	P1IFG.0 to P1IFG.3 (P1IV)	Maskable	FFECCh	54
P2	P2IFG.0, P2IFG.1, P2IFG.6 and P2IFG.7 (P2IV)	Maskable	FFEAh	53
eCOMP0	CPIIFG, CPIFG (CPIV)	Maskable	FFE8h	52
Reserved	Reserved	Maskable	FFE6h–FF88h	
Signatures	BSL Signature 2		0FF86h	
	BSL Signature 1		0FF84h	
	JTAG Signature 2		0FF82h	
	JTAG Signature 1		0FF80h	

6.5 Memory Organization

Table 6-3 summarizes the memory map of the MSP430FR211x devices.

Table 6-3. Memory Organization

	ACCESS	MSP430FR2111	MSP430FR2110
Memory (FRAM) Main: interrupt vectors and signatures Main: code memory	Read/Write (Optional Write Protect) ⁽¹⁾	3.75KB FFFFh–FF80h FFFFh–F100h	2KB FFFFh–FF80h FFFFh–F800h
RAM	Read/Write	1KB 23FFh–2000h	1KB 23FFh–2000h
Bootloader (BSL) Memory (ROM) (TI Internal Use)	Read only	1KB 13FFh–1000h	1KB 13FFh–1000h
Peripherals	Read/Write	4KB 0FFFh–0000h	4KB 0FFFh–0000h

(1) The Program FRAM can be write protected by setting the PFWP bit in the SYSCFG0 register. See the SYS chapter in the [MSP430FR4xx and MSP430FR2xx Family User's Guide](#) for more details

6.6 Bootloader (BSL)

The BSL lets users program the FRAM or RAM using a UART interface. Access to the device memory through the BSL is protected by an user-defined password. Table 6-4 lists the BSL pin requirements. BSL entry requires a specific entry sequence on the $\overline{\text{RST}}/\text{NMI}/\text{SBWTDIO}$ and TEST/SBWTCK pins. For a complete description of the features of the BSL and its implementation, see the [MSP430FR4xx and MSP430FR2xx Bootloader \(BSL\) User's Guide](#).

Table 6-4. UART BSL Pin Requirements and Functions

DEVICE SIGNAL	BSL FUNCTION
$\overline{\text{RST}}/\text{NMI}/\text{SBWTDIO}$	Entry sequence signal
TEST/SBWTCK	Entry sequence signal
P1.7	Data transmit
P1.6	Data receive
VCC	Power Supply
VSS	Ground Supply

6.7 JTAG Standard Interface

The MSP430 family supports the standard JTAG interface, which requires four signals for sending and receiving data. The JTAG signals are shared with general-purpose I/Os. The TEST/SBWTCK pin is used to enable the JTAG signals. The $\overline{\text{RST}}/\text{NMI}/\text{SBWTDIO}$ pin is also required to interface with MSP430 development tools and device programmers. Table 6-5 lists the JTAG pin requirements. For details on interfacing to development tools and device programmers, see the [MSP430 Hardware Tools User's Guide](#).

Table 6-5. JTAG Pin Requirements and Function

DEVICE SIGNAL	DIRECTION	JTAG FUNCTION
P1.4/UCA0STE/TCK/A4	IN	JTAG clock input
P1.5/UCA0CLK/TMS/A5	IN	JTAG state control
P1.6/UCA0RXD/UCA0SOMI/TB0.1/TDI/TCLK/A6	IN	JTAG data input, TCLK input
P1.7/UCA0TXD/UCA0SIMO/TB0.2/TDO/A7/VREF+	OUT	JTAG data output
TEST/SBWTCK	IN	Enable JTAG pins
$\overline{\text{RST}}/\text{NMI}/\text{SBWTDIO}$	IN	External reset
VCC		Power supply
VSS		Ground supply

6.8 Spy-Bi-Wire Interface (SBW)

The MSP430 family supports the 2-wire Spy-Bi-Wire interface. Spy-Bi-Wire can be used to interface with MSP430 development tools and device programmers. [Table 6-6](#) lists the Spy-Bi-Wire interface pin requirements. For further details on interfacing to development tools and device programmers, see the [MSP430 Hardware Tools User's Guide](#).

Table 6-6. Spy-Bi-Wire Pin Requirements and Functions

DEVICE SIGNAL	DIRECTION	SBW FUNCTION
TEST/SBWTCK	IN	Spy-Bi-Wire clock input
RST/NMI/SBWDIO	IN, OUT	Spy-Bi-Wire data input and output
VCC		Power supply
VSS		Ground supply

6.9 FRAM

The FRAM can be programmed using the JTAG port, Spy-Bi-Wire (SBW), the BSL, or in-system by the CPU. Features of the FRAM include:

- Byte and word access capability
- Programmable wait state generation
- Error correction coding (ECC)

6.10 Memory Protection

The device features memory protection of user access authority and write protection include:

- Securing the whole memory map to prevent unauthorized access from JTAG port or BSL, by writing JTAG and BSL signatures using the JTAG port, SBW, the BSL, or in-system by the CPU.
- Write protection enabled to prevent unwanted write operation to FRAM contents by setting the control bits with accordingly password in System Configuration register 0. For more detailed information, see the SYS chapter in the [MSP430FR4xx and MSP430FR2xx Family User's Guide](#).

6.11 Peripherals

Peripherals are connected to the CPU through data, address, and control buses. All peripherals can be handled by using all instructions in the memory map. For complete module description, see the [MSP430FR4xx and MSP430FR2xx Family User's Guide](#).

6.11.1 Power-Management Module (PMM) and On-Chip Reference Voltages

The PMM includes an integrated voltage regulator that supplies the core voltage to the device. The PMM also includes supply voltage supervisor (SVS) and brownout protection. The brownout reset circuit (BOR) is implemented to provide the proper internal reset signal to the device during power on and power off. The SVS circuitry detects if the supply voltage drops below a user-selectable safe level. SVS circuitry is available on the primary supply.

The device contains two on-chip reference: 1.5 V for internal reference and 1.2 V for external reference.

The 1.5-V reference is internally connected to ADC channel 13. DVCC is internally connected to ADC channel 15. When DVCC is set as the reference voltage for ADC conversion, the DVCC can be easily represent as [Equation 1](#) by using the ADC sampling the 1.5-V reference without any external components support.

$$DVCC = (1023 \times 1.5 \text{ V}) / 1.5\text{-V Reference ADC result} \quad (1)$$

The 1.5-V reference is also internally connected to the comparator built-in DAC as reference voltage. DVCC is internally connected to another source of the DAC reference, and both are controlled by the CPDACREFS bit. For more detailed information, see the Comparator chapter of the [MSP430FR4xx and MSP430FR2xx Family User's Guide](#).

A 1.2-V reference voltage can be buffered and output to P1.7/TDO/A7/VREF+, when EXTREFEN = 1 in the PMMCTL2 register. ADC channel 7 can also be selected to monitor this voltage. For more detailed information, see the [MSP430FR4xx and MSP430FR2xx Family User's Guide](#).

6.11.2 Clock System (CS) and Clock Distribution

The clock system includes a 32-kHz low-frequency oscillator (XT1), an internal very-low-power low-frequency oscillator (VLO), an integrated 32-kHz RC oscillator (REFO), an integrated internal digitally controlled oscillator (DCO) that may use frequency-locked loop (FLL) locking with an internal or external 32-kHz reference clock, and on-chip asynchronous high-speed clock (MODOSC). The clock system is designed to target cost-effective designs with minimal external components. A fail-safe mechanism is designed for XT1. The clock system module offers the following clock signals.

- Main Clock (MCLK): the system clock used by the CPU and all relevant peripherals accessed by the bus. All clock sources except MODOSC can be selected as the source with a predivider of 1, 2, 4, 8, 16, 32, 64, or 128.
- Sub-Main Clock (SMCLK): the subsystem clock used by the peripheral modules. SMCLK derives from the MCLK with a predivider of 1, 2, 4, or 8. This means SMCLK is always equal to or less than MCLK.
- Auxiliary Clock (ACLK): this clock is derived from the external XT1 clock or internal REFO clock up to 40 kHz.

All peripherals may have one or several clock sources depending on specific functionality. [Table 6-7](#) and [Table 6-8](#) summarize the clock distribution used in this device.

Table 6-7. Clock Distribution

	CLOCK SOURCE SELECT BITS	MCLK	SMCLK	ACLK	MODCLK	VLOCLK	EXTERNAL PIN
Frequency Range		DC to 16 MHz	DC to 16 MHz	DC to 40 kHz	4 MHz	10 kHz	
CPU	N/A	Default					
FRAM	N/A	Default					
RAM	N/A	Default					
CRC	N/A	Default					
I/O	N/A	Default					
TB0	TBSSEL		10b	01b			00b (TB0CLK pin)
eUSCI_A0	UCSSEL		10b or 11b	01b			00b (UCA0CLK pin)
WDT	WDTSSSEL		00b	01b		10b	
ADC	ADCSSSEL		10b or 11b	01b	00b		
RTC	RTCSS		01b	01b		11b	

Table 6-8. XTCLK Distribution

OPERATION MODE	CLOCK SOURCE SELECT BITS	XTLFCLK
		AM TO LPM3.5 (DC to 40 kHz)
MCLK	SEMS	10b
SMCLK	SEMS	10b
REFO	SELREF	0b
ACLK	SELA	0b
RTC	RTCSS	10b

6.11.3 General-Purpose Input/Output Port (I/O)

Up to 12 I/O ports are implemented.

- P1 has 8 bits implemented, and P2 has 4 bits implemented.
- All individual I/O bits are independently programmable.
- Any combination of input, output, and interrupt conditions is possible to P1 and P2.
- Programmable pullup or pulldown on all ports.
- Edge-selectable interrupt, LPM4, LPM3.5 and LPM4.5 wake-up input capability is available for P1.0 to P1.3, P2.0, P2.1, P2.6, and P2.7.
- Read and write access to port-control registers is supported by all instructions.
- Ports can be accessed byte-wise or word-wise in pairs.
- Capacitive Touch I/O functionality is supported on all pins.

NOTE

Configuration of digital I/Os after BOR reset

To prevent any cross currents during start-up of the device, all port pins are high-impedance with Schmitt triggers and module functions disabled. To enable the I/O functions after a BOR reset, the ports must be configured first and then the LOCKLPM5 bit must be cleared. For details, see the *Configuration After Reset* section in the Digital I/O chapter of the [MSP430FR4xx and MSP430FR2xx Family User's Guide](#).

6.11.4 Watchdog Timer (WDT)

The primary function of the WDT module is to perform a controlled system restart after a software problem occurs. If the selected time interval expires, a system reset is generated. If the watchdog function is not needed in an application, the module can be configured as interval timer and can generate interrupts at selected time intervals.

Table 6-9. WDT Clocks

WDTSEL	NORMAL OPERATION (WATCHDOG AND INTERVAL TIMER MODE)
00	SMCLK
01	ACLK
10	VLOCLK
11	Reserved

6.11.5 System Module (SYS)

The SYS module handles many of the system functions within the device. These system functions include power-on reset (POR) and power-up clear (PUC) handling, NMI source selection and management, reset interrupt vector generators, bootloader entry mechanisms, and configuration management (device descriptors). SYS also includes a data exchange mechanism through SBW called a JTAG mailbox that can be used in the application. [Table 6-10](#) lists the SYS module interrupt vector registers.

Table 6-10. System Module Interrupt Vector Registers

INTERRUPT VECTOR REGISTER	ADDRESS	INTERRUPT EVENT	VALUE	PRIORITY
SYSRSTIV, System Reset	015Eh	No interrupt pending	00h	
		Brownout (BOR)	02h	Highest
		RSTIFGRST/NMI (BOR)	04h	
		PMMSWBOR software BOR (BOR)	06h	
		LPMx.5 wakeup (BOR)	08h	
		Security violation (BOR)	0Ah	
		Reserved	0Ch	
		SVSHIFG SVSH event (BOR)	0Eh	
		Reserved	10h	
		Reserved	12h	
		PMMSWPOR software POR (POR)	14h	
		WDTIFG watchdog time-out (PUC)	16h	
		WDTPW password violation (PUC)	18h	
		FRCTLPW password violation (PUC)	1Ah	
		Uncorrectable FRAM bit error detection	1Ch	
		Peripheral area fetch (PUC)	1Eh	
		PMMPW PMM password violation (PUC)	20h	
		Reserved	22h	
		FLL unlock (PUC)	24h	
Reserved	26h to 3Eh	Lowest		
SYSSNIV, System NMI	015Ch	No interrupt pending	00h	
		SVS low-power reset entry	02h	Highest
		Uncorrectable FRAM bit error detection	04h	
		Reserved	06h	
		Reserved	08h	
		Reserved	0Ah	
		Reserved	0Ch	
		Reserved	0Eh	
		Reserved	10h	
		VMAIFG Vacant memory access	12h	
		JMBINIFG JTAG mailbox input	14h	
		JMBOUTIFG JTAG mailbox output	16h	
		Correctable FRAM bit error detection	18h	
		Reserved	1Ah to 1Eh	Lowest
		SYSUNIV, User NMI	015Ah	No interrupt pending
NMIIFG NMI pin or SVS _H event	02h			Highest
OFIFG oscillator fault	04h			
Reserved	06h to 1Eh			Lowest

6.11.6 Cyclic Redundancy Check (CRC)

The 16-bit CRC module produces a signature based on a sequence of data values and can be used for data checking purposes. The CRC generation polynomial is compliant with CRC-16-CCITT standard of $x^{16} + x^{12} + x^5 + 1$.

6.11.7 Enhanced Universal Serial Communication Interface (eUSCI_A0)

The eUSCI modules are used for serial data communications. The eUSCI_A module supports either UART or SPI communications. Additionally, eUSCI_A supports automatic baud-rate detection and IrDA.

Table 6-11. eUSCI Pin Configurations

eUSCI_A0	PIN (USCIARMP = 0)	UART	SPI
	P1.7	TXD	SIMO
	P1.6	RXD	SOMI
	P1.5		SCLK
	P1.4		STE
	PIN (USCIARMP = 1)	UART	SPI
	P1.3 ⁽¹⁾	TXD	SIMO
	P1.2 ⁽¹⁾	RXD	SOMI
	P1.1 ⁽¹⁾		SCLK
	P1.0 ⁽¹⁾		STE

(1) This is the remapped functionality controlled by the USCIARMP bit in the SYSCFG3 register. Only one selected port is valid at the same time when TB0 acts as capture input functionality. TB0 PWM outputs regardless of this remap bit control.

6.11.8 Timers (Timer0_B3)

The Timer0_B3 module is 16-bit timer and counter with three capture/compare registers. The timer can support multiple captures or compares, PWM outputs, and interval timing (see [Table 6-12](#)). Timer0_B3 has extensive interrupt capabilities. Interrupts may be generated from the counter on overflow conditions and from each of the capture/compare registers. The CCR0 register on Timer0_B3 is not externally connected and can be used only for hardware period timing and interrupt generation. In Up Mode, it can be used to set the overflow value of the counter.

Table 6-12. Timer0_B3 Signal Connections

PORT PIN	DEVICE INPUT SIGNAL	MODULE INPUT NAME	MODULE BLOCK	MODULE OUTPUT SIGNAL	DEVICE OUTPUT SIGNAL	
P2.7	TB0CLK	TBCLK	Timer	N/A		
	ACLK (internal)	ACLK				
	SMCLK (internal)	SMCLK				
	From Capacitive Touch I/O (internal)	INCLK				
	From RTC (internal)	CCI0A	CCR0	TB0		
	ACLK (internal)	CCI0B				
	DVSS	GND				
	DVCC	VCC				
P1.6 (TBRMP = 0) P2.0 (TBRMP = 1) ⁽¹⁾	TB0.1	CCI1A	CCR1	TB1	TB0.1	
		From eCOMP (internal)			CCI1B	To ADC trigger
		DVSS			GND	
		DVCC			VCC	
P1.7 (TBRMP = 0) P2.1 (TBRMP = 1) ⁽¹⁾	TB0.2	CCI2A	CCR2	TB2	TB0.2	
		From Capacitive Touch I/O (internal)			CCI2B	
		DVSS			GND	
		DVCC			VCC	

(1) This is the remapped functionality controlled by the TBRMP bit in the SYSCFG3 register. Only one selected port is valid at the same time.

The interconnection of Timer0_B3 can be used to modulate the eUSCI_A pin of UCA0TXD/UCA0SIMO in either ASK or part of FSK mode, with which a user can easily acquire a modulated infrared command for directly driving an external IR diode. The IR functions are fully controlled by SYSCFG1 including IREN (enable), IRPSEL (polarity select), IRMSEL (mode select), IRDSEL (data select), and IRDATA (data) bits. For more information, see the SYS chapter in the [MSP430FR4xx and MSP430FR2xx Family User's Guide](#).

The Timer_B module can put all Timer_B outputs into a high-impedance state when the selected source is triggered. The source can be selected from external pin or internal of the device, which is controlled by TB0TRG in SYS. For more information, see the SYS chapter in the [MSP430FR4xx and MSP430FR2xx Family User's Guide](#).

Table 6-13 summarizes the selection of the Timer_B high-impedance trigger.

Table 6-13. TBxOUTH

TB0TRGSEL	TB0OUTH TRIGGER SOURCE SELECTION	Timer_B PAD OUTPUT HIGH IMPEDANCE
TB0TRGSEL = 0	eCOMP0 output (internal)	P1.6, P1.7, P2.0, P2.1 ⁽¹⁾
TB0TRGSEL = 1	P1.2	

(1) When TB0 is set to PWM output function, both port groups can receive the output, and the output is controlled by only the PxSEL.y bits.

6.11.9 Backup Memory (BAKMEM)

The BAKMEM supports data retention functionality during LPM3.5 mode. This device provides up to 32 bytes that are retained during LPM3.5.

6.11.10 Real-Time Clock (RTC) Counter

The RTC counter is a 16-bit modulo counter that is functional in AM, LPM0, LPM3, LPM4, and LPM3.5. This module may periodically wake up the CPU from LPM0, LPM3, LPM4, or LPM3.5 based on timing from a low-power clock source such as XT1, ACLK, or VLO. In AM, RTC can be driven by SMCLK to generate high-frequency timing events and interrupts. ACLK and SMCLK both can source to the RTC; however, only one of them can be selected at any given time. The RTC overflow events trigger:

- Timer0_B3 CCR0A
- ADC conversion trigger when ADCSHSx bits are set as 01b

6.11.11 10-Bit Analog-to-Digital Converter (ADC)

The 10-bit ADC module supports fast 10-bit analog-to-digital conversions with single-ended input. The module implements a 10-bit SAR core, sample select control, reference generator, and a conversion result buffer. A window comparator with lower and upper limits allows CPU-independent result monitoring with three window comparator interrupt flags.

The ADC supports 10 external inputs and 4 internal inputs (see [Table 6-14](#)).

Table 6-14. ADC Channel Connections

ADCSHSx	ADC CHANNELS	EXTERNAL PIN OUT
0	A0/Veref+	P1.0
1	A1/	P1.1
2	A2/Veref-	P1.2
3	A3	P1.3
4	A4	P1.4
5	A5	P1.5
6	A6	P1.6
7	A7 ⁽¹⁾	P1.7
8	Not used	N/A
9	Not used	N/A
10	Not used	N/A
11	Not used	N/A
12	On-chip temperature sensor	N/A
13	Reference voltage (1.5 V)	N/A
14	DVSS	N/A
15	DVCC	N/A

(1) When A7 is used, the PMM 1.2-V reference voltage can be output to this pin by setting the PMM control register. The 1.2-V voltage can be directly measured by A7 channel.

The conversion can be started by software or a hardware trigger. [Table 6-15](#) lists the trigger sources that are available.

Table 6-15. ADC Trigger Signal Connections

ADCSHSx		TRIGGER SOURCE
BINARY	DECIMAL	
00	0	ADCSC bit (software trigger)
01	1	RTC event
10	2	TB0.1B
11	3	eCOMP0 COUT

6.11.12 eCOMP0

The enhanced comparator is an analog voltage comparator with built-in 6-bit DAC as an internal voltage reference. The integrated 6-bit DAC can be set up to 64 steps for comparator reference voltage. This module has 4-level programmable hysteresis and a configurable power mode: high-power or low-power mode.

The eCOMP0 supports external inputs and internal inputs (see [Table 6-16](#)) and outputs (see [Table 6-17](#))

Table 6-16. eCOMP0 Input Channel Connections

CPPSEL, CPNSEL	eCOMP0 CHANNELS	EXTERNAL OR INTERNAL CONNECTION
BINARY		
000	C0	P1.0
001	C1	P1.1
010	C2	P1.2
011	C3	P1.3
100	C4	Not used
101	C5	Not used
110	C6	Built-in 6-bit DAC

Table 6-17. eCOMP0 Output Channel Connections

eCOMP0 Out	EXTERNAL PIN OUT, MODULE
1	P2.0
2	TB0.1B ; TB0 (TB0OUTH); ADC

6.11.13 Embedded Emulation Module (EEM)

The EEM supports real-time in-system debugging. The EEM on these devices has the following features:

- Three hardware triggers or breakpoints on memory access
- One hardware trigger or breakpoint on CPU register write access
- Up to four hardware triggers that can be combined to form complex triggers or breakpoints
- One cycle counter
- Clock control on module level

6.11.14 Peripheral File Map

Table 6-18 lists the base address and the memory size of the registers for each peripheral, and Table 6-19 through Table 6-32 list all of the available registers for each peripheral and their address offsets.

Table 6-18. Peripherals Summary

MODULE NAME	BASE ADDRESS	SIZE
Special Functions (see Table 6-19)	0100h	0010h
PMM (see Table 6-20)	0120h	0020h
SYS (see Table 6-21)	0140h	0040h
CS (see Table 6-22)	0180h	0020h
FRAM (see Table 6-23)	01A0h	0010h
CRC (see Table 6-24)	01C0h	0008h
WDT (see Table 6-25)	01CCh	0002h
Port P1, P2 (see Table 6-26)	0200h	0020h
Capacitive Touch I/O (see Table 6-27)	02E0h	0010h
RTC (see Table 6-28)	0300h	0010h
Timer0_B3 (see Table 6-29)	0380h	0030h
eUSCI_A0 (see Table 6-30)	0500h	0020h
Backup Memory (see Table 6-31)	0660h	0020h
ADC (see Table 6-32)	0700h	0040h
eCOMP0 (see Table 6-33)	08E0h	0020h

Table 6-19. Special Function Registers (Base Address: 0100h)

REGISTER DESCRIPTION	REGISTER	OFFSET
SFR interrupt enable	SFRIE1	00h
SFR interrupt flag	SFRIFG1	02h
SFR reset pin control	SFRRPCR	04h

Table 6-20. PMM Registers (Base Address: 0120h)

REGISTER DESCRIPTION	REGISTER	OFFSET
PMM control 0	PMMCTL0	00h
PMM Control 1	PMMCTL1	02h
PMM Control 2	PMMCTL2	04h
PMM interrupt flags	PMMIFG	0Ah
PM5 control 0	PM5CTL0	10h

Table 6-21. SYS Registers (Base Address: 0140h)

REGISTER DESCRIPTION	REGISTER	OFFSET
System control	SYSCCTL	00h
Bootloader configuration area	SYSBSLC	02h
JTAG mailbox control	SYSJMBC	06h
JTAG mailbox input 0	SYSJMBI0	08h
JTAG mailbox input 1	SYSJMBI1	0Ah
JTAG mailbox output 0	SYSJMBO0	0Ch
JTAG mailbox output 1	SYSJMBO1	0Eh
Bus Error vector generator	SYSBERRIV	18h
User NMI vector generator	SYSUNIV	1Ah
System NMI vector generator	SYSSNIV	1Ch
Reset vector generator	SYSRSTIV	1Eh
System configuration 0	SYSCFG0	20h
System configuration 1	SYSCFG1	22h
System configuration 2	SYSCFG2	24h
System configuration 3	SYSCFG3	26h

Table 6-22. CS Registers (Base Address: 0180h)

REGISTER DESCRIPTION	REGISTER	OFFSET
CS control 0	CSCTL0	00h
CS control 1	CSCTL1	02h
CS control 2	CSCTL2	04h
CS control 3	CSCTL3	06h
CS control 4	CSCTL4	08h
CS control 5	CSCTL5	0Ah
CS control 6	CSCTL6	0Ch
CS control 7	CSCTL7	0Eh
CS control 8	CSCTL8	10h

Table 6-23. FRAM Registers (Base Address: 01A0h)

REGISTER DESCRIPTION	REGISTER	OFFSET
FRAM control 0	FRCTL0	00h
General control 0	GCCTL0	04h
General control 1	GCCTL1	06h

Table 6-24. CRC Registers (Base Address: 01C0h)

REGISTER DESCRIPTION	REGISTER	OFFSET
CRC data input	CRC16DI	00h
CRC data input reverse byte	CRCDIRB	02h
CRC initialization and result	CRCINIRES	04h
CRC result reverse byte	CRCRESR	06h

Table 6-25. WDT Registers (Base Address: 01CCh)

REGISTER DESCRIPTION	REGISTER	OFFSET
Watchdog timer control	WDTCTL	00h

Table 6-26. Port P1, P2 Registers (Base Address: 0200h)

REGISTER DESCRIPTION	REGISTER	OFFSET
Port P1 input	P1IN	00h
Port P1 output	P1OUT	02h
Port P1 direction	P1DIR	04h
Port P1 pulling enable	P1REN	06h
Port P1 selection 0	P1SEL0	0Ah
Port P1 selection 1	P1SEL1	0Ch
Port P1 interrupt vector word	P1IV	0Eh
Port P1 interrupt edge select	P1IES	18h
Port P1 interrupt enable	P1IE	1Ah
Port P1 interrupt flag	P1IFG	1Ch
Port P2 input	P2IN	01h
Port P2 output	P2OUT	03h
Port P2 direction	P2DIR	05h
Port P2 pulling enable	P2REN	07h
Port P2 selection 0	P2SEL0	0Bh
Port P2 selection 1	P2SEL1	0Dh
Port P2 interrupt vector word	P2IV	1Eh
Port P2 interrupt edge select	P2IES	19h
Port P2 interrupt enable	P2IE	1Bh
Port P2 interrupt flag	P2IFG	1Dh

Table 6-27. Capacitive Touch I/O Registers (Base Address: 02E0h)

REGISTER DESCRIPTION	REGISTER	OFFSET
Capacitive Touch I/O 0 control	CAPIO0CTL	0Eh

Table 6-28. RTC Registers (Base Address: 0300h)

REGISTER DESCRIPTION	REGISTER	OFFSET
RTC control	RTCCTL	00h
RTC interrupt vector	RTCIV	04h
RTC modulo	RTCMOD	08h
RTC counter	RTCCNT	0Ch

Table 6-29. Timer0_B3 Registers (Base Address: 0380h)

REGISTER DESCRIPTION	REGISTER	OFFSET
TB0 control	TB0CTL	00h
Capture/compare control 0	TB0CCTL0	02h
Capture/compare control 1	TB0CCTL1	04h
Capture/compare control 2	TB0CCTL2	06h
TB0 counter	TB0R	10h
Capture/compare 0	TB0CCR0	12h
Capture/compare 1	TB0CCR1	14h
Capture/compare 2	TB0CCR2	16h
TB0 expansion 0	TB0EX0	20h
TB0 interrupt vector	TB0IV	2Eh

Table 6-30. eUSCI_A0 Registers (Base Address: 0500h)

REGISTER DESCRIPTION	REGISTER	OFFSET
eUSCI_A control word 0	UCA0CTLW0	00h
eUSCI_A control word 1	UCA0CTLW1	02h
eUSCI_A control rate 0	UCA0BR0	06h
eUSCI_A control rate 1	UCA0BR1	07h
eUSCI_A modulation control	UCA0MCTLW	08h
eUSCI_A status	UCA0STAT	0Ah
eUSCI_A receive buffer	UCA0RXBUF	0Ch
eUSCI_A transmit buffer	UCA0TXBUF	0Eh
eUSCI_A LIN control	UCA0ABCTL	10h
eUSCI_A IrDA transmit control	IUCA0IRTCTL	12h
eUSCI_A IrDA receive control	IUCA0IRRCTL	13h
eUSCI_A interrupt enable	UCA0IE	1Ah
eUSCI_A interrupt flags	UCA0IFG	1Ch
eUSCI_A interrupt vector word	UCA0IV	1Eh

Table 6-31. Backup Memory Registers (Base Address: 0660h)

REGISTER DESCRIPTION	REGISTER	OFFSET
Backup memory 0	BAKMEM0	00h
Backup memory 1	BAKMEM1	02h
Backup memory 2	BAKMEM2	04h
Backup memory 3	BAKMEM3	06h
Backup memory 4	BAKMEM4	08h
Backup memory 5	BAKMEM5	0Ah
Backup memory 6	BAKMEM6	0Ch
Backup memory 7	BAKMEM7	0Eh
Backup memory 8	BAKMEM8	10h
Backup memory 9	BAKMEM9	12h
Backup memory 10	BAKMEM10	14h
Backup memory 11	BAKMEM11	16h
Backup memory 12	BAKMEM12	18h
Backup memory 13	BAKMEM13	1Ah
Backup memory 14	BAKMEM14	1Ch
Backup memory 15	BAKMEM15	1Eh

Table 6-32. ADC Registers (Base Address: 0700h)

REGISTER DESCRIPTION	REGISTER	OFFSET
ADC control 0	ADCCTL0	00h
ADC control 1	ADCCTL1	02h
ADC control 2	ADCCTL2	04h
ADC window comparator low threshold	ADCLO	06h
ADC window comparator high threshold	ADCHI	08h
ADC memory control 0	ADCMCTL0	0Ah
ADC conversion memory	ADCMEM0	12h
ADC interrupt enable	ADCIE	1Ah
ADC interrupt flags	ADCIFG	1Ch
ADC interrupt vector word	ADCIV	1Eh

Table 6-33. eCOMP0 Registers (Base Address: 08E0h)

REGISTER DESCRIPTION	REGISTER	OFFSET
Comparator control 0	CPCTL0	00h
Comparator control 1	CPCTL1	02h
Comparator interrupt	CPINT	06h
Comparator interrupt vector	CPIV	08h
Comparator built-in DAC control	CPDACCTL	10h
Comparator built-in DAC data	CPDACDATA	12h

6.11.15 Input/Output Diagrams

6.11.15.1 Port P1 Input/Output With Schmitt Trigger

Figure 6-1 shows the port diagram. Table 6-34 summarizes the selection of the pin functions.

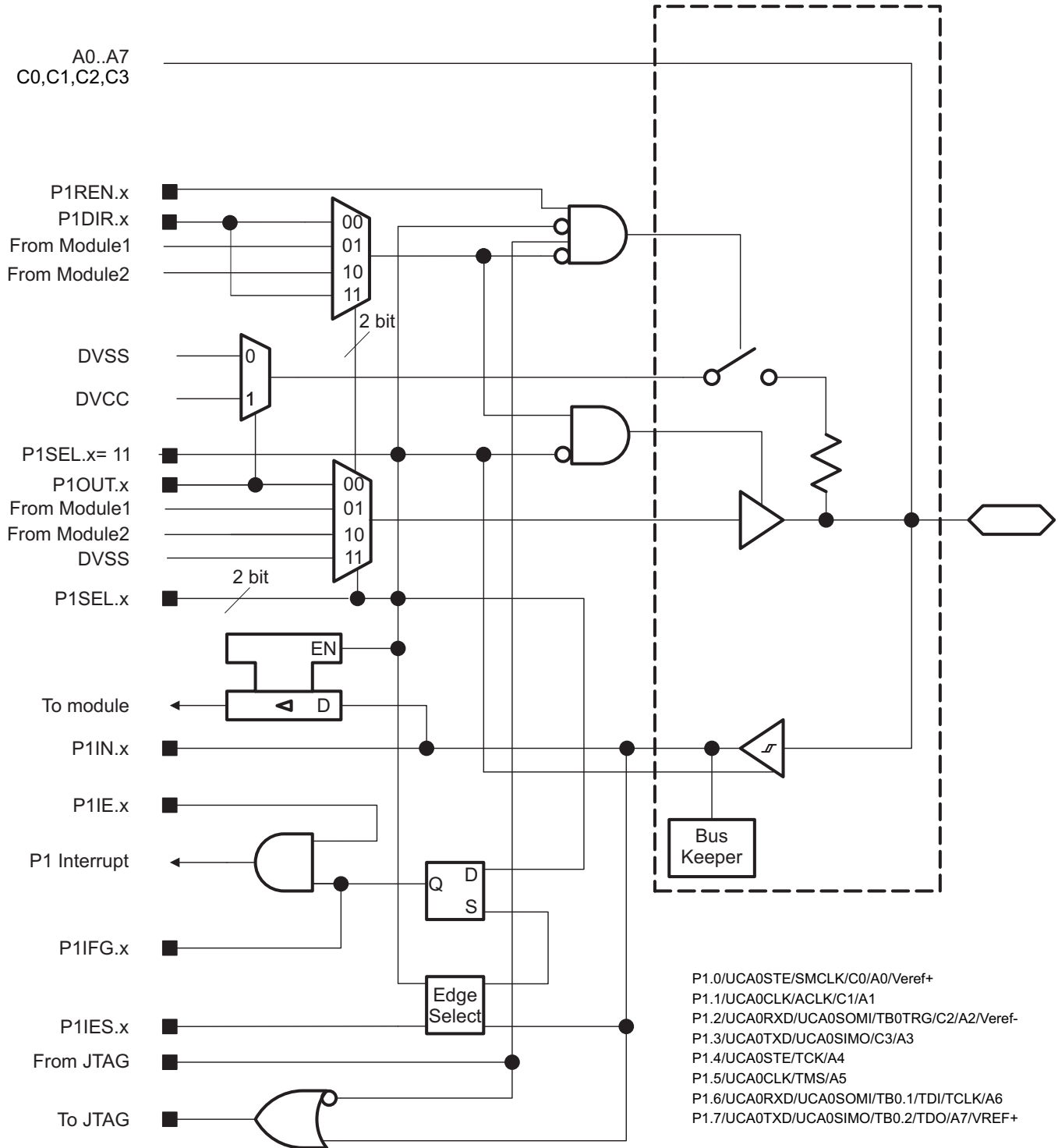

Figure 6-1. Port P1 Input/Output With Schmitt Trigger

Table 6-34. Port P1 Pin Functions

PIN NAME (P1.x)	x	FUNCTION	CONTROL BITS AND SIGNALS ⁽¹⁾		
			P1DIR.x	P1SELx	JTAG
P1.0/UCA0STE/SMCLK/ C0/A0/Veref+	0	P1.0 (I/O)	I: 0; O: 1	00	N/A
		UCA0STE	X	01	N/A
		SMCLK	1	10	N/A
		VSS	0		
		C0, A0/Veref+	X	11	N/A
P1.1/UCA0CLK/ACLK/ C1/A1	1	P1.1 (I/O)	I: 0; O: 1	0	N/A
		UCA0CLK	X	01	N/A
		ACLK	1	10	N/A
		VSS	0		
		C1, A1	X	11	N/A
P1.2/UCA0RXD/ UCA0SOMI/TB0TRG/ C2/A2/Veref-	2	P1.2 (I/O)	I: 0; O: 1	00	N/A
		UCA0RXD/UCA0SOMI	X	01	N/A
		TB0TRG	0	10	N/A
		C2, A2/Veref-	X	11	N/A
P1.3/UCA0TXD/ UCA0SIMO/C3/A3	3	P1.3 (I/O)	I: 0; O: 1	00	N/A
		UCA0TXD/UCA0SIMO	X	01	N/A
		C3, A3	X	11	N/A
P1.4/UCA0STE/TCK/A4	4	P1.4 (I/O)	I: 0; O: 1	00	Disabled
		UCA0STE	X	01	N/A
		A4	X	11	Disabled
		JTAG TCK	X	X	TCK
P1.5/UCA0CLK/TMS/A5	5	P1.5 (I/O)	I: 0; O: 1	00	Disabled
		UCA0CLK	X	01	N/A
		A5	X	11	Disabled
		JTAG TMS	X	X	TMS
P1.6/UCA0RXD/ UCA0SOMI/TB0.1/ TDI/TCLK/A6	6	P1.6 (I/O)	I: 0; O: 1	00	Disabled
		UCA0RXD/UCA0SOMI	X	01	N/A
		TB0.CCI1A	0	10	N/A
		TB0.1	1		
		A6	X	11	Disabled
		JTAG TDI/TCLK	X	X	TDI/TCLK
P1.7/UCA0TXD/ UCA0SIMO/TB0.2/ TDO/A7/VREF+	7	P1.7 (I/O)	I: 0; O: 1	00	Disabled
		UCA0TXD/UCA0SIMO	X	01	N/A
		TB0.CCI2A	0	10	N/A
		TB0.2	1		
		A7, VREF+	X	11	Disabled
		JTAG TDO	X	X	TDO

(1) X = don't care

6.11.15.2 Port P2 Input/Output With Schmitt Trigger

Figure 6-2 shows the port diagram. Table 6-35 summarizes the selection of the pin functions.

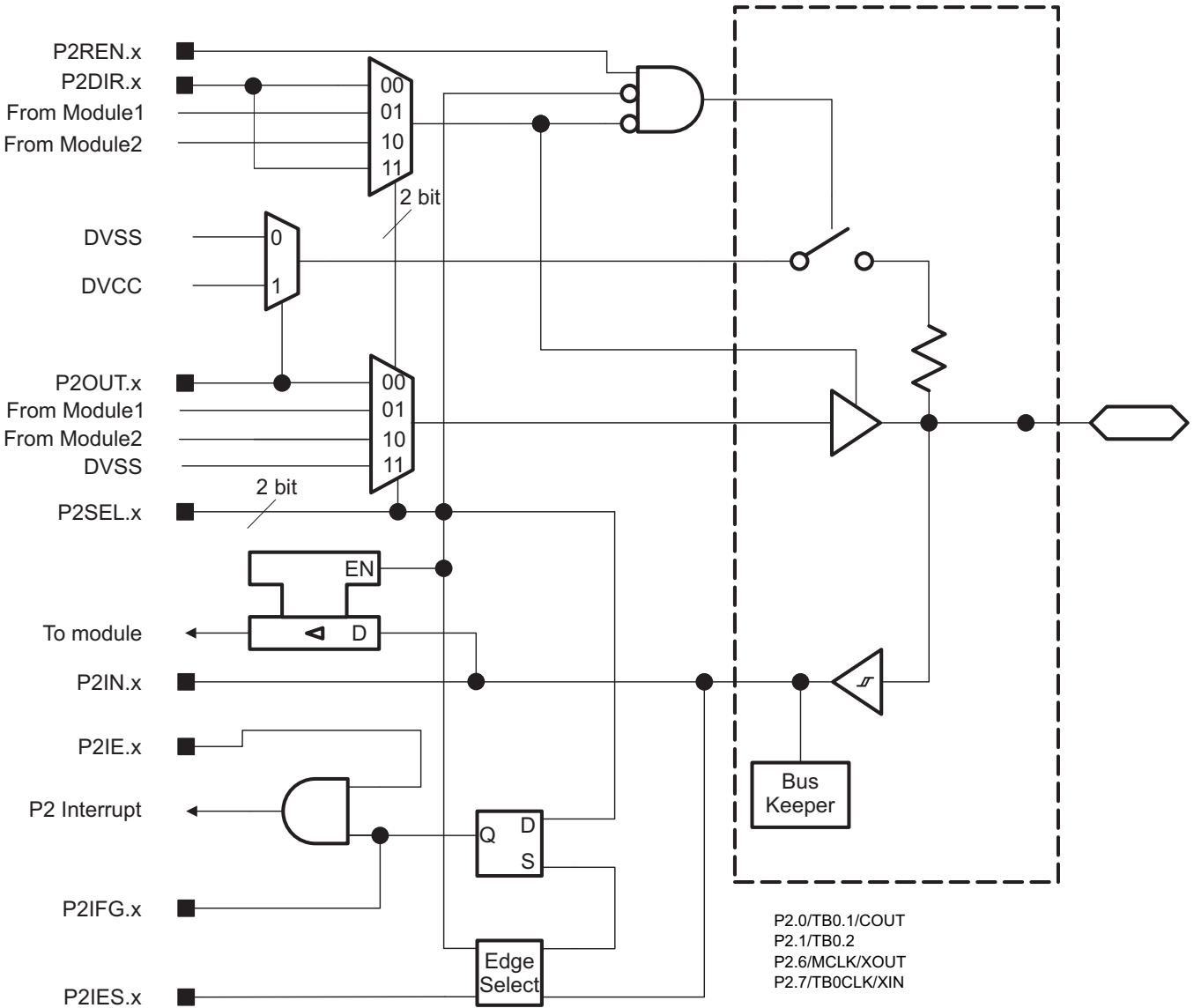

Figure 6-2. Port P2 Input/Output With Schmitt Trigger

Table 6-35. Port P2 Pin Functions

PIN NAME (P2.x)	x	FUNCTION	CONTROL BITS AND SIGNALS ⁽¹⁾	
			P2DIR.x	P2SELx
P2.0/TB0.1/COU ^T	0	P2.0 (I/O)	I: 0; O: 1	00
		TB0.CCI1A	0	01
		TB0.1	1	
		COU ^T	1	10
P2.1/TB0.2	1	P2.1 (I/O)0	I: 0; O: 1	00
		TB0.CCI2A	0	01
		TB0.2	1	
P2.6/MCLK/XOU ^T	6	P2.6 (I/O)	I: 0; O: 1	00
		MCLK	1	01
		VSS	0	
		XOU ^T	X	10
P2.7/TB0CLK/XIN	7	P2.7 (I/O)	I: 0; O: 1	00
		TB0CLK	0	01
		VSS	1	
		XIN	X	10

(1) X = don't care

6.12 Device Descriptors (TLV)

Table 6-36 lists the Device IDs of the MSP430FR211x MCUs. Table 6-37 lists the contents of the device descriptor tag-length-value (TLV) structure for MSP430FR211x MCUs.

Table 6-36. Device IDs

DEVICE	DEVICE ID	
	1A04h	1A05h
MSP430FR2111	FA	82
MSP430FR2110	FB	82

Table 6-37. Device Descriptors

	DESCRIPTION	MSP430FR211x	
		ADDRESS	VALUE
Info Block	Info length	1A00h	06h
	CRC length	1A01h	06h
	CRC value ⁽¹⁾	1A02h	Per unit
		1A03h	Per unit
	Device ID	1A04h	See Table 6-36.
		1A05h	
	Hardware revision	1A06h	Per unit
Firmware revision	1A07h	Per unit	
Die Record	Die record tag	1A08h	08h
	Die record length	1A09h	0Ah
	Lot wafer ID	1A0Ah	Per unit
		1A0Bh	Per unit
		1A0Ch	Per unit
		1A0Dh	Per unit
	Die X position	1A0Eh	Per unit
		1A0Fh	Per unit
	Die Y position	1A10h	Per unit
		1A11h	Per unit
Test result	1A12h	Per unit	
	1A13h	Per unit	
ADC Calibration	ADC calibration tag	1A14h	Per unit
	ADC calibration length	1A15h	Per unit
	ADC gain factor	1A16h	Per unit
		1A17h	Per unit
	ADC offset	1A18h	Per unit
		1A19h	Per unit
	ADC 1.5-V reference temperature 30°C	1A1Ah	Per unit
		1A1Bh	Per unit
ADC 1.5-V reference temperature 85°C	1A1Ch	Per unit	
	1A1Dh	Per unit	

(1) CRC value covers the check sum from 0x1A04h to 0x1A77h by applying CRC-CCITT-16 polynomial of $X^{16} + X^{12} + X^5 + 1$

Table 6-37. Device Descriptors (continued)

	DESCRIPTION	MSP430FR211x	
		ADDRESS	VALUE
Reference and DCO Calibration	Calibration tag	1A1Eh	12h
	Calibration length	1A1Fh	04h
	1.5-V reference factor	1A20h	Per unit
		1A21h	Per unit
	DCO tap settings for 16 MHz, temperature 30°C ⁽²⁾	1A22h	Per unit
		1A23h	Per unit

(2) This value can be directly loaded into DCO bits in CSCTL0 register to get accurate 16-MHz frequency at room temperature, especially when the MCU exits from LPM3 and below. TI suggests using a predivider to decrease the frequency if the temperature drift might result an overshoot beyond 16 MHz.

6.13 Identification

6.13.1 Revision Identification

The device revision information is shown as part of the top-side marking on the device package. The device-specific errata sheet describes these markings. For links to all of the errata sheets for the devices in this data sheet, see [Section 8.4](#).

The hardware revision is also stored in the Device Descriptor structure in the Info Block section. For details on this value, see the "Hardware Revision" entries in [Section 6.12](#).

6.13.2 Device Identification

The device type can be identified from the top-side marking on the device package. The device-specific errata sheet describes these markings. For links to all of the errata sheets for the devices in this data sheet, see [Section 8.4](#).

A device identification value is also stored in the Device Descriptor structure in the Info Block section. For details on this value, see the "Device ID" entries in [Section 6.12](#).

6.13.3 JTAG Identification

Programming through the JTAG interface, including reading and identifying the JTAG ID, is described in detail in [MSP430 Programming With the JTAG Interface](#).

7 Applications, Implementation, and Layout

NOTE

Information in the following applications sections is not part of the TI component specification, and TI does not warrant its accuracy or completeness. TI's customers are responsible for determining suitability for components for their purposes. Customers should validate and test their implementation to confirm system functionality.

7.1 Device Connection and Layout Fundamentals

This section describes the recommended guidelines when designing with the MSP430. These guidelines are to make sure that the device has proper connections for powering, programming, debugging, and optimum analog performance.

7.1.1 Power Supply Decoupling and Bulk Capacitors

TI recommends connecting a combination of a 10- μ F capacitor and a 100-nF low-ESR ceramic decoupling capacitor to the DVCC pin. Higher-value capacitors may be used but can impact supply rail ramp-up time. Decoupling capacitors must be placed as close as possible to the pins that they decouple (within a few millimeters).

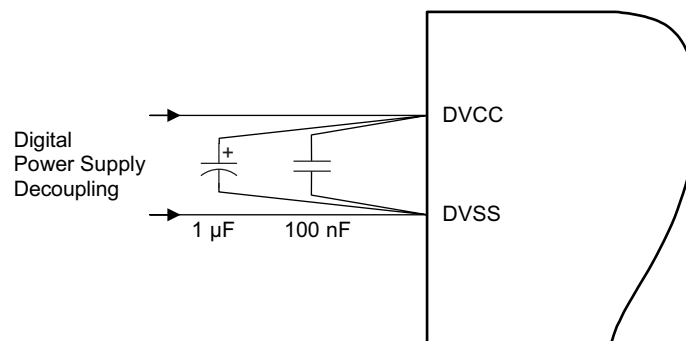

Figure 7-1. Power Supply Decoupling

7.1.2 External Oscillator

Depending on the device variant (see [Table 3-1](#)), the device supports only a low-frequency crystal (32 kHz) on the LFXT pins. External bypass capacitors for the crystal oscillator pins are required.

It is also possible to apply digital clock signals to the LFXIN input pins that meet the specifications of the respective oscillator if the appropriate LFXTBYPASS mode is selected. In this case, the associated LFXOUT pins can be used for other purposes. If the LFXOUT pins are left unused, they must be terminated according to [Section 4.5](#).

[Figure 7-2](#) shows a typical connection diagram. See [MSP430 32-kHz Crystal Oscillators](#) for information on selecting, testing, and designing a crystal oscillator with the MSP430 devices.

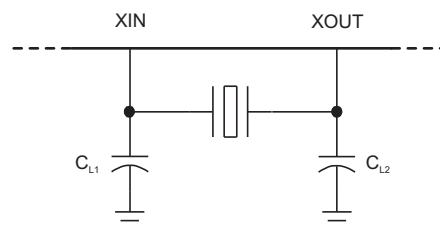

Figure 7-2. Typical Crystal Connection

7.1.3 JTAG

With the proper connections, the debugger and a hardware JTAG interface (such as the MSP-FET or MSP-FET430UIF) can be used to program and debug code on the target board. In addition, the connections also support the MSP-GANG production programmers, thus providing an easy way to program prototype boards, if desired. Figure 7-3 shows the connections between the 14-pin JTAG connector and the target device required to support in-system programming and debugging for 4-wire JTAG communication. Figure 7-4 shows the connections for 2-wire JTAG mode (Spy-Bi-Wire).

The connections for the MSP-FET and MSP-FET430UIF interface modules and the MSP-GANG are identical. Both can supply VCC to the target board (through pin 2). In addition, the MSP-FET and MSP-FET430UIF interface modules and MSP-GANG have a VCC sense feature that, if used, requires an alternate connection (pin 4 instead of pin 2). The VCC-sense feature senses the local VCC present on the target board (that is, a battery or other local power supply) and adjusts the output signals accordingly. Figure 7-3 and Figure 7-4 show a jumper block that supports both scenarios of supplying VCC to the target board. If this flexibility is not required, the desired VCC connections may be hardwired to eliminate the jumper block. Pins 2 and 4 must not be connected at the same time.

For additional design information regarding the JTAG interface, see the [MSP430 Hardware Tools User's Guide](#).

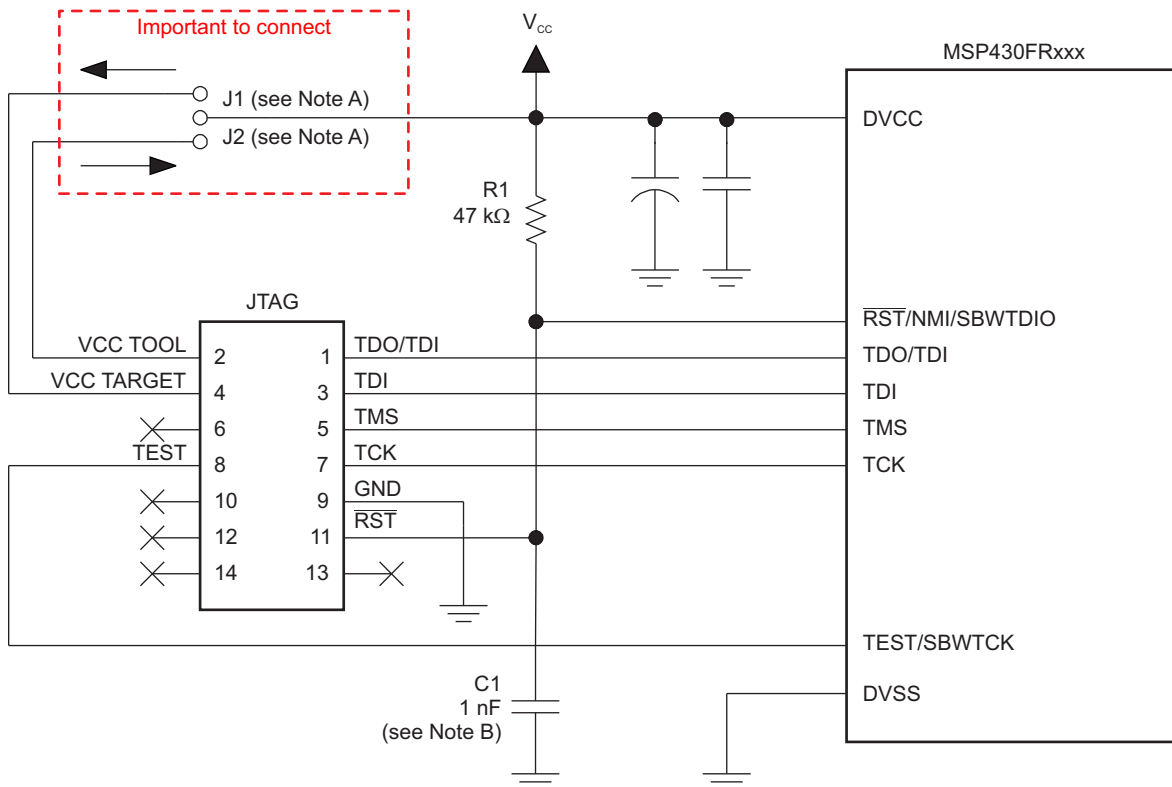

Copyright © 2016, Texas Instruments Incorporated

- A. If a local target power supply is used, make connection J1. If power from the debug or programming adapter is used, make connection J2.
- B. The upper limit for C1 is 1.1 nF when using current TI tools.

Figure 7-3. Signal Connections for 4-Wire JTAG Communication

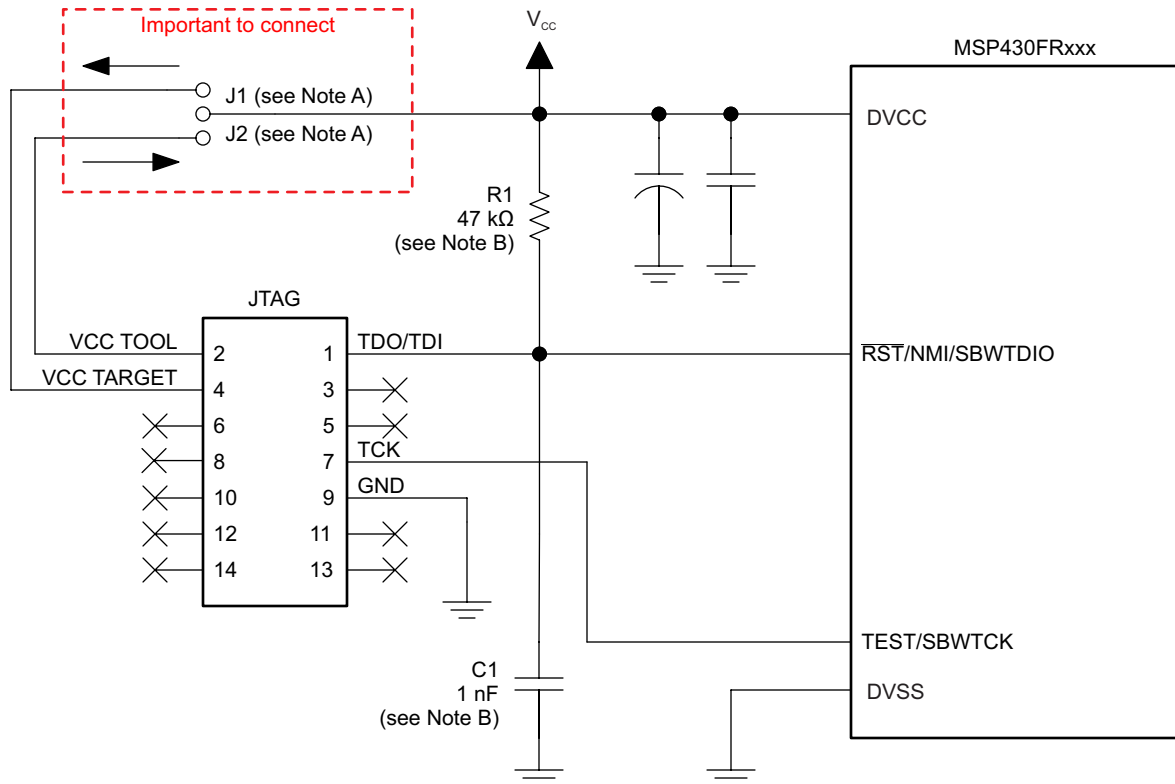

Copyright © 2016, Texas Instruments Incorporated

- Make connection J1 if a local target power supply is used, or make connection J2 if the target is powered from the debug or programming adapter.
- The device $\overline{\text{RST/NMI/SBWTIO}}$ pin is used in 2-wire mode for bidirectional communication with the device during JTAG access, and any capacitance that is attached to this signal may affect the ability to establish a connection with the device. The upper limit for C1 is 1.1 nF when using current TI tools.

Figure 7-4. Signal Connections for 2-Wire JTAG Communication (Spy-Bi-Wire)

7.1.4 Reset

The reset pin can be configured as a reset function (default) or as an NMI function in the Special Function Register (SFR), SFRRPCR.

In reset mode, the $\overline{\text{RST/NMI}}$ pin is active low, and a pulse applied to this pin that meets the reset timing specifications generates a BOR-type device reset.

Setting SYSNMI causes the $\overline{\text{RST/NMI}}$ pin to be configured as an external NMI source. The external NMI is edge sensitive, and its edge is selectable by SYSNMIIES. Setting the NMIIE enables the interrupt of the external NMI. When an external NMI event occurs, the NMIIFG is set.

The $\overline{\text{RST/NMI}}$ pin can have either a pullup or pulldown that is enabled or not. SYSRSTUP selects either pullup or pulldown, and SYSRSTRE causes the pullup (default) or pulldown to be enabled (default) or not. If the $\overline{\text{RST/NMI}}$ pin is unused, it is required either to select and enable the internal pullup or to connect an external 47-kΩ pullup resistor to the $\overline{\text{RST/NMI}}$ pin with a 10-nF pulldown capacitor. The pulldown capacitor should not exceed 1.1 nF when using devices with Spy-Bi-Wire interface in Spy-Bi-Wire mode or in 4-wire JTAG mode with TI tools like FET interfaces or GANG programmers.

See the [MSP430FR4xx and MSP430FR2xx Family User's Guide](#) for more information on the referenced control registers and bits.

7.1.5 Unused Pins

For details on the connection of unused pins, see [Section 4.5](#).

7.1.6 General Layout Recommendations

- Proper grounding and short traces for external crystal to reduce parasitic capacitance. See [MSP430 32-kHz Crystal Oscillators](#) for recommended layout guidelines.
- Proper bypass capacitors on DVCC, AVCC, and reference pins if used.
- Avoid routing any high-frequency signal close to an analog signal line. For example, keep digital switching signals such as PWM or JTAG signals away from the oscillator circuit and ADC signals.
- See [Circuit Board Layout Techniques](#) for a detailed discussion of PCB layout considerations. This document is written primarily about op amps, but the guidelines are generally applicable for all mixed-signal applications.
- Proper ESD level protection should be considered to protect the device from unintended high-voltage electrostatic discharge. See [MSP430 System-Level ESD Considerations](#) for guidelines.

7.1.7 Do's and Don'ts

During power up, power down, and device operation, the voltage difference between AVCC and DVCC must not exceed the limits specified in the [Absolute Maximum Ratings](#) section. Exceeding the specified limits may cause malfunction of the device including erroneous writes to RAM and FRAM.

7.2 Peripheral- and Interface-Specific Design Information

7.2.1 ADC Peripheral

7.2.1.1 Partial Schematic

Figure 7-5 shows the recommended decoupling circuit with either an internal or an external voltage reference.

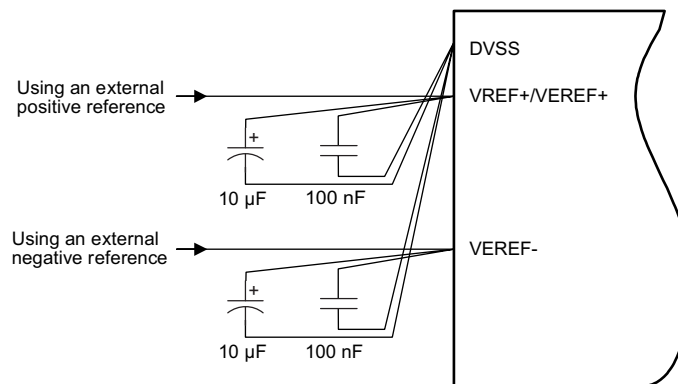

Figure 7-5. ADC Grounding and Noise Considerations

7.2.1.2 Design Requirements

As with any high-resolution ADC, appropriate printed-circuit-board layout and grounding techniques should be followed to eliminate ground loops, unwanted parasitic effects, and noise.

Ground loops are formed when return current from the ADC flows through paths that are common with other analog or digital circuitry. If care is not taken, this current can generate small unwanted offset voltages that can add to or subtract from the reference or input voltages of the ADC. The general guidelines in [Section 7.1.1](#) combined with the connections shown in [Section 7.2.1.1](#) prevent this.

In addition to grounding, ripple and noise spikes on the power-supply lines that are caused by digital switching or switching power supplies can corrupt the conversion result. TI recommends a noise-free design using separate analog and digital ground planes with a single-point connection to achieve high accuracy.

Figure 7-5 shows the recommended decoupling circuit when an external voltage reference is used. The internal reference module has a maximum drive current as described in the sections *ADC Pin Enable* and *1.2-V Reference Settings* of the *MSP430FR4xx and MSP430FR2xx Family User's Guide*.

The reference voltage must be a stable voltage for accurate measurements. The capacitor values that are selected in the general guidelines filter out the high- and low-frequency ripple before the reference voltage enters the device. In this case, the 10- μ F capacitor is used to buffer the reference pin and filter any low-frequency ripple. A bypass capacitor of 100 nF is used to filter out any high-frequency noise.

7.2.1.3 Layout Guidelines

Components that are shown in the partial schematic (see Figure 7-5) should be placed as close as possible to the respective device pins to avoid long traces, because they add additional parasitic capacitance, inductance, and resistance on the signal.

Avoid routing analog input signals close to a high-frequency pin (for example, a high-frequency PWM), because the high-frequency switching can be coupled into the analog signal.

7.3 Typical Applications

Table 7-1 lists several TI Designs that reflect the use of the MSP430FR211x family of devices in different real-world application scenarios. Consult these designs for additional guidance regarding schematic, layout, and software implementation. For the most up-to-date list of available TI Designs, see the device-specific product folders listed in Section 8.5.

Table 7-1. TI Designs

DESIGN NAME	LINK
Thermostat Implementation With MSP430FR4xx	TIDM-FRAM-THERMOSTAT
Water Meter Implementation With MSP430FR4xx	TIDM-FRAM-WATERMETER
Remote Controller of Air Conditioner Using Low-Power Microcontroller	TIDM-REMOTE-CONTROLLER-FOR-AC

8 Device and Documentation Support

8.1 Getting Started and Next Steps

For more information on the MSP430™ family of devices and the tools and libraries that are available to help with your development, visit the [Getting Started](#) page.

8.2 Device Nomenclature

To designate the stages in the product development cycle, TI assigns prefixes to the part numbers of all MSP430 MCU devices and support tools. Each MSP430 MCU commercial family member has one of three prefixes: MSP, PMS, or XMS (for example, MSP430FR2111). Texas Instruments recommends two of three possible prefix designators for its support tools: MSP and MSPX. These prefixes represent evolutionary stages of product development from engineering prototypes (with XMS for devices and MSPX for tools) through fully qualified production devices and tools (with MSP for devices and MSP for tools).

Device development evolutionary flow:

XMS – Experimental device that is not necessarily representative of the final device's electrical specifications

MSP – Fully qualified production device

Support tool development evolutionary flow:

MSPX – Development-support product that has not yet completed Texas Instruments internal qualification testing.

MSP – Fully-qualified development-support product

XMS devices and MSPX development-support tools are shipped against the following disclaimer:

"Developmental product is intended for internal evaluation purposes."

MSP devices and MSP development-support tools have been characterized fully, and the quality and reliability of the device have been demonstrated fully. TI's standard warranty applies.

Predictions show that prototype devices (XMS) have a greater failure rate than the standard production devices. Texas Instruments recommends that these devices not be used in any production system because their expected end-use failure rate still is undefined. Only qualified production devices are to be used.

TI device nomenclature also includes a suffix with the device family name. This suffix indicates the package type (for example, PM) and temperature range (for example, T). [Figure 8-1](#) provides a legend for reading the complete device name for any family member.

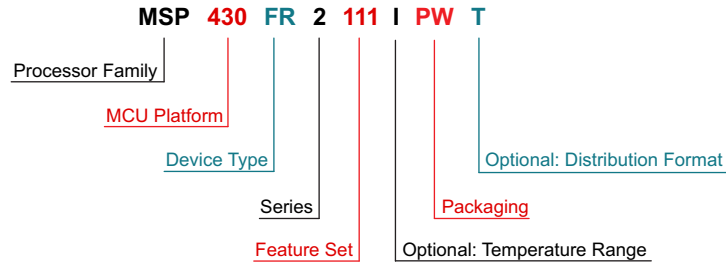

Processor Family	MSP = Mixed-Signal Processor XMS = Experimental Silicon	
MCU Platform	430 = TI's 16-bit MSP430 Low-Power Microcontroller Platform	
Device Type	Memory Type FR = FRAM	
Series	FRAM 4 Series = Up to 16 MHz with LCD FRAM 2 Series = Up to 16 MHz without LCD	
Feature Set	1st and 2nd Digits: ADC Channels / COMP / eUSCI / 16-bit Timers / I/O 11 = Up to 8 / 1 / 1 / 1 / Up to 12	3rd Digit: FRAM (KB) / SRAM (KB) 1 = 4 / 1 0 = 2 / 1
Optional: Temperature Range	S = 0°C to 50°C I = -40°C to 85°C T = -40°C to 105°C	
Packaging	www.ti.com/packaging	
Optional: Distribution Format	T = Small reel R = Large reel No marking = Tube or tray	

Figure 8-1. Device Nomenclature

8.3 Tools and Software

All MSP microcontrollers are supported by a wide variety of software and hardware development tools. Tools are available from TI and various third parties. See them all at [Development Kits and Software for Low-Power MCUs](#).

Table 8-1 lists the debug features of the MSP430FR211x microcontrollers. See the [Code Composer Studio for MSP430 User's Guide](#) for details on the available features.

Table 8-1. Hardware Debug Features

MSP430 ARCHITECTURE	4-WIRE JTAG	2-WIRE JTAG	BREAK-POINTS (N)	RANGE BREAK-POINTS	CLOCK CONTROL	STATE SEQUENCER	TRACE BUFFER	LPMX.5 DEBUGGING SUPPORT	EEM VERSION
MSP430Xv2	Yes	Yes	3	Yes	Yes	No	No	No	S

Design Kits and Evaluation Modules

MSP430FR4133 LaunchPad™ Development Kit The MSP-EXP430FR4133 LaunchPad Development Kit is a microcontroller development board for the MSP430FR2xx and MSP430FR4xx MCU families. Like the MSP-EXP430FR2311 board, this kit contains everything needed to evaluate the MSP430FR2x/4x FRAM platforms, including onboard emulation for programming, debugging, and energy measurements. Similarly, the onboard buttons and LEDs allow for integration of simple user interaction, while the 20-pin header for BoosterPack™ plug-in modules (found on both boards) allows for the use of BoosterPack modules – or for quick user experimentation. This kit is recommended for evaluating the MSP430FR2x/4x software architecture, while the MSP-TS430PW20 is suitable when moving code to MSP430FR21x silicon.

MSP430FR2311 LaunchPad Development Kit The MSP-EXP430FR2311 LaunchPad Development Kit is a microcontroller development board for the MSP430FR21x/23x MCU families. This kit contains everything needed to evaluate the MSP430FR21x FRAM platform, including onboard emulation for programming, debugging, and energy measurements. The onboard buttons and LEDs allow for integration of simple user interaction.

20-pin Target Socket Development Board for MSP430FR23x/21x MCUs The MSP-TS430PW20 is a stand-alone ZIF socket target board used to program and debug the MSP430 in-system through the JTAG interface or the Spy Bi-Wire (2-wire JTAG) protocol. The development board supports all MSP430FR23x and MSP430FR21x FRAM MCUs in a 20-pin or 16-pin TSSOP package (TI package code: PW).

MSP-FET + MSP-TS430PW20 FRAM Microcontroller Development Kit Bundle The MSP-FET430U20 bundle combines two debugging tools that support the 20-pin PW package for the MSP430FR23x and MSP430FR21x microcontrollers (for example, MSP430FR2311PW20). These two tools include: MSP-TS430PW20 and MSP-FET.

Software

MSP430FR211x Code Examples C Code examples are available for every MSP device that configures each of the integrated peripherals for various application needs.

MSP Driver Library The abstracted API of MSP Driver Library provides easy-to-use function calls that free you from directly manipulating the bits and bytes of the MSP430 hardware. Thorough documentation is delivered through a helpful API Guide, which includes details on each function call and the recognized parameters. Developers can use Driver Library functions to write complete projects with minimal overhead.

ULP (Ultra-Low Power) Advisor ULP Advisor™ software is a tool for guiding developers to write more efficient code to fully use the unique ultra-low-power features of MSP and MSP432 microcontrollers. Aimed at both experienced and new microcontroller developers, ULP Advisor checks your code against a thorough ULP checklist to help minimize the energy consumption of your application. At build time, ULP Advisor provides notifications and remarks to highlight areas of your code that can be further optimized for lower power.

IEC60730 Software Package The IEC60730 MSP430 software package was developed to help customers comply with IEC 60730-1:2010 (Automatic Electrical Controls for Household and Similar Use – Part 1: General Requirements) for up to Class B products, which includes home appliances, arc detectors, power converters, power tools, e-bikes, and many others. The IEC60730 MSP430 software package can be embedded in customer applications running on MSP430s to help simplify the customer's certification efforts of functional safety-compliant consumer devices to IEC 60730-1:2010 Class B.

Fixed Point Math Library for MSP The MSP IQmath and Qmath Libraries are a collection of highly optimized and high-precision mathematical functions for C programmers to seamlessly port a floating-point algorithm into fixed-point code on MSP430 and MSP432 devices. These routines are typically used in computationally intensive real-time applications where optimal execution speed, high accuracy, and ultra-low energy are critical. By using the IQmath and Qmath libraries, it is possible to achieve execution speeds considerably faster and energy consumption considerably lower than equivalent code written using floating-point math.

Floating Point Math Library for MSP430 Continuing to innovate in the low-power and low-cost microcontroller space, TI provides MSPMATHLIB. Leveraging the intelligent peripherals of our devices, this floating-point math library of scalar functions that are up to 26 times faster than the standard MSP430 math functions. Mathlib is easy to integrate into your designs. This library is free and is integrated in both Code Composer Studio IDE and IAR Embedded Workbench IDE.

Development Tools

Code Composer Studio™ Integrated Development Environment for MSP Microcontrollers Code Composer Studio (CCS) integrated development environment (IDE) supports all MSP microcontroller devices. CCS comprises a suite of embedded software utilities used to develop and debug embedded applications. It includes an optimizing C/C++ compiler, source code editor, project build environment, debugger, profiler, and many other features.

MSP EnergyTrace™ Technology EnergyTrace technology for MSP430 microcontrollers is an energy-based code analysis tool that measures and displays the energy profile of the application and helps to optimize it for ultra-low-power consumption.

MSP430Ware™ Software MSP430Ware software is a collection of code examples, data sheets, and other design resources for all MSP devices delivered in a convenient package. In addition to providing a complete collection of existing MSP design resources, MSP430Ware software also includes a high-level API called MSP Driver Library. This library makes it easy to program MSP hardware. MSP430Ware software is available as a component of CCS or as a stand-alone package.

Command-Line Programmer MSP Flasher is an open-source shell-based interface for programming MSP microcontrollers through a FET programmer or eZ430 using JTAG or Spy-Bi-Wire (SBW) communication. MSP Flasher can download binary files (.txt or .hex) directly to the MSP microcontroller without an IDE.

MSP MCU Programmer and Debugger The MSP-FET is a powerful emulation development tool – often called a debug probe – which lets users quickly begin application development on MSP low-power MCUs. Creating MCU software usually requires downloading the resulting binary program to the MSP device for validation and debugging.

MSP-GANG Production Programmer The MSP Gang Programmer is an MSP430 or MSP432 device programmer that can program up to eight identical MSP430 or MSP432 flash or FRAM devices at the same time. The MSP Gang Programmer connects to a host PC using a standard RS-232 or USB connection and provides flexible programming options that let the user fully customize the process.

8.4 Documentation Support

The following documents describe the MSP430FR211x microcontrollers. Copies of these documents are available on the Internet at www.ti.com.

Receiving Notification of Document Updates

To receive notification of documentation updates—including silicon errata—go to the product folder for your device on ti.com (see [Section 8.5](#) for links to product folders). In the upper right corner, click the "Alert me" button. This registers you to receive a weekly digest of product information that has changed (if any). For change details, check the revision history of any revised document.

Errata

MSP430FR2111 Device Erratasheet Describes the known exceptions to the functional specifications for all silicon revisions of this device.

MSP430FR2110 Device Erratasheet Describes the known exceptions to the functional specifications for all silicon revisions of this device.

User's Guides

MSP430FR4xx and MSP430FR2xx Family User's Guide Detailed information on the modules and peripherals available in this device family.

Code Composer Studio v6.1 for MSP430 User's Guide This manual describes the use of TI Code Composer Studio IDE v6.1 (CCS v6.1) with the MSP430 ultra-low-power microcontrollers. This document applies only for the Windows version of the Code Composer Studio IDE. The Linux version is similar and, therefore, is not described separately.

IAR Embedded Workbench Version 3+ for MSP430 User's Guide This manual describes the use of IAR Embedded Workbench (EW430) with the MSP430 ultra-low-power microcontrollers.

MSP430 Programming With the Bootloader (BSL) The MSP430 bootloader (BSL, formerly known as the bootstrap loader) allows users to communicate with embedded memory in the MSP430 microcontroller during the prototyping phase, final production, and in service. Both the programmable memory (flash memory) and the data memory (RAM) can be modified as required. Do not confuse the bootloader with the bootstrap loader programs found in some digital signal processors (DSPs) that automatically load program code (and data) from external memory to the internal memory of the DSP.

MSP430 Programming With the JTAG Interface This document describes the functions that are required to erase, program, and verify the memory module of the MSP430 flash-based and FRAM-based microcontroller families using the JTAG communication port. In addition, it describes how to program the JTAG access security fuse that is available on all MSP430 devices. This document describes device access using both the standard 4-wire JTAG interface and the 2-wire JTAG interface, which is also referred to as Spy-Bi-Wire (SBW).

MSP430 Hardware Tools User's Guide This manual describes the hardware of the TI MSP-FET430 Flash Emulation Tool (FET). The FET is the program development tool for the MSP430 ultra-low-power microcontroller.

Application Reports

MSP430 FRAM Technology – How To and Best Practices FRAM is a nonvolatile memory technology that behaves similar to SRAM while enabling a whole host of new applications, but also changing the way firmware should be designed. This application report outlines the how to and best practices of using FRAM technology in MSP430 from an embedded software development perspective. It discusses how to implement a memory layout according to application-specific code, constant, data space requirements, and the use of FRAM to optimize application energy consumption.

VLO Calibration on the MSP430FR4xx and MSP430FR2xx Family MSP430FR4xx and MSP430FR2xx (FR4xx/FR2xx) family microcontrollers (MCUs) provide various clock sources, including some high-speed high-accuracy clocks and some low-power low-system-cost clocks. Users can select the best balance of performance, power consumption, and system cost. The on-chip very low-frequency oscillator (VLO) is a clock source with 10-kHz typical frequency included in FR4xx/FR2xx family MCUs. The VLO is widely used in a range of applications because of its ultra-low power consumption.

MSP430 32-kHz Crystal Oscillators Selection of the right crystal, correct load circuit, and proper board layout are important for a stable crystal oscillator. This application report summarizes crystal oscillator function and explains the parameters to select the correct crystal for MSP430 ultra-low-power operation. In addition, hints and examples for correct board layout are given. The document also contains detailed information on the possible oscillator tests to ensure stable oscillator operation in mass production.

MSP430 System-Level ESD Considerations System-Level ESD has become increasingly demanding with silicon technology scaling towards lower voltages and the need for designing cost-effective and ultra-low-power components. This application report addresses three different ESD topics to help board designers and OEMs understand and design robust system-level designs.

8.5 Related Links

Table 8-2 lists quick access links. Categories include technical documents, support and community resources, tools and software, and quick access to sample or buy.

Table 8-2. Related Links

PARTS	PRODUCT FOLDER	SAMPLE & BUY	TECHNICAL DOCUMENTS	TOOLS & SOFTWARE	SUPPORT & COMMUNITY
MSP430FR2111	Click here	Click here	Click here	Click here	Click here
MSP430FR2110	Click here	Click here	Click here	Click here	Click here

8.6 Community Resources

The following links connect to TI community resources. Linked contents are provided "AS IS" by the respective contributors. They do not constitute TI specifications and do not necessarily reflect TI's views; see TI's [Terms of Use](#).

[TI E2E™ Community](#)

TI's Engineer-to-Engineer (E2E) Community. Created to foster collaboration among engineers. At [e2e.ti.com](#), you can ask questions, share knowledge, explore ideas, and help solve problems with fellow engineers.

[TI Embedded Processors Wiki](#)

Texas Instruments Embedded Processors Wiki. Established to help developers get started with embedded processors from Texas Instruments and to foster innovation and growth of general knowledge about the hardware and software surrounding these devices.

8.7 Trademarks

MSP430, LaunchPad, header for BoosterPack, ULP Advisor, Code Composer Studio, EnergyTrace, MSP430Ware, E2E are trademarks of Texas Instruments.

8.8 Electrostatic Discharge Caution



This integrated circuit can be damaged by ESD. Texas Instruments recommends that all integrated circuits be handled with appropriate precautions. Failure to observe proper handling and installation procedures can cause damage.

ESD damage can range from subtle performance degradation to complete device failure. Precision integrated circuits may be more susceptible to damage because very small parametric changes could cause the device not to meet its published specifications.

8.9 Glossary

[TI Glossary](#) This glossary lists and explains terms, acronyms, and definitions.

9 Mechanical, Packaging, and Orderable Information

The following pages include mechanical, packaging, and orderable information. This information is the most current data available for the designated devices. This data is subject to change without notice and revision of this document. For browser-based versions of this data sheet, refer to the left-hand navigation.

PACKAGING INFORMATION

Orderable Device	Status (1)	Package Type	Package Drawing	Pins	Package Qty	Eco Plan (2)	Lead/Ball Finish (6)	MSL Peak Temp (3)	Op Temp (°C)	Device Marking (4/5)	Samples
MSP430FR2110IPW16	ACTIVE	TSSOP	PW	16	90	Green (RoHS & no Sb/Br)	CU NIPDAU	Level-2-260C-1 YEAR	-40 to 85	FR2110	Samples
MSP430FR2110IPW16R	ACTIVE	TSSOP	PW	16	2000	Green (RoHS & no Sb/Br)	CU NIPDAU	Level-2-260C-1 YEAR	-40 to 85	FR2110	Samples
MSP430FR2110IRLLR	ACTIVE	VQFN	RLL	24	3000	Green (RoHS & no Sb/Br)	CU NIPDAU	Level-2-260C-1 YEAR	-40 to 85	FR2110	Samples
MSP430FR2110IRLLT	ACTIVE	VQFN	RLL	24	250	Green (RoHS & no Sb/Br)	CU NIPDAU	Level-2-260C-1 YEAR	-40 to 85	FR2110	Samples
MSP430FR2111IPW16	ACTIVE	TSSOP	PW	16	90	Green (RoHS & no Sb/Br)	CU NIPDAU	Level-2-260C-1 YEAR	-40 to 85	FR2111	Samples
MSP430FR2111IPW16R	ACTIVE	TSSOP	PW	16	2000	Green (RoHS & no Sb/Br)	CU NIPDAU	Level-2-260C-1 YEAR	-40 to 85	FR2111	Samples
MSP430FR2111IRLLR	ACTIVE	VQFN	RLL	24	3000	Green (RoHS & no Sb/Br)	CU NIPDAU	Level-2-260C-1 YEAR	-40 to 85	FR2111	Samples
MSP430FR2111IRLLT	ACTIVE	VQFN	RLL	24	250	Green (RoHS & no Sb/Br)	CU NIPDAU	Level-2-260C-1 YEAR	-40 to 85	FR2111	Samples

(1) The marketing status values are defined as follows:

ACTIVE: Product device recommended for new designs.

LIFEBUY: TI has announced that the device will be discontinued, and a lifetime-buy period is in effect.

NRND: Not recommended for new designs. Device is in production to support existing customers, but TI does not recommend using this part in a new design.

PREVIEW: Device has been announced but is not in production. Samples may or may not be available.

OBSOLETE: TI has discontinued the production of the device.

(2) Eco Plan - The planned eco-friendly classification: Pb-Free (RoHS), Pb-Free (RoHS Exempt), or Green (RoHS & no Sb/Br) - please check <http://www.ti.com/productcontent> for the latest availability information and additional product content details.

TBD: The Pb-Free/Green conversion plan has not been defined.

Pb-Free (RoHS): TI's terms "Lead-Free" or "Pb-Free" mean semiconductor products that are compatible with the current RoHS requirements for all 6 substances, including the requirement that lead not exceed 0.1% by weight in homogeneous materials. Where designed to be soldered at high temperatures, TI Pb-Free products are suitable for use in specified lead-free processes.

Pb-Free (RoHS Exempt): This component has a RoHS exemption for either 1) lead-based flip-chip solder bumps used between the die and package, or 2) lead-based die adhesive used between the die and leadframe. The component is otherwise considered Pb-Free (RoHS compatible) as defined above.

Green (RoHS & no Sb/Br): TI defines "Green" to mean Pb-Free (RoHS compatible), and free of Bromine (Br) and Antimony (Sb) based flame retardants (Br or Sb do not exceed 0.1% by weight in homogeneous material)

(3) MSL, Peak Temp. - The Moisture Sensitivity Level rating according to the JEDEC industry standard classifications, and peak solder temperature.

(4) There may be additional marking, which relates to the logo, the lot trace code information, or the environmental category on the device.

(5) Multiple Device Markings will be inside parentheses. Only one Device Marking contained in parentheses and separated by a "~" will appear on a device. If a line is indented then it is a continuation of the previous line and the two combined represent the entire Device Marking for that device.

(6) Lead/Ball Finish - Orderable Devices may have multiple material finish options. Finish options are separated by a vertical ruled line. Lead/Ball Finish values may wrap to two lines if the finish value exceeds the maximum column width.

Important Information and Disclaimer:The information provided on this page represents TI's knowledge and belief as of the date that it is provided. TI bases its knowledge and belief on information provided by third parties, and makes no representation or warranty as to the accuracy of such information. Efforts are underway to better integrate information from third parties. TI has taken and continues to take reasonable steps to provide representative and accurate information but may not have conducted destructive testing or chemical analysis on incoming materials and chemicals. TI and TI suppliers consider certain information to be proprietary, and thus CAS numbers and other limited information may not be available for release.

In no event shall TI's liability arising out of such information exceed the total purchase price of the TI part(s) at issue in this document sold by TI to Customer on an annual basis.

PW (R-PDSO-G16)

PLASTIC SMALL OUTLINE

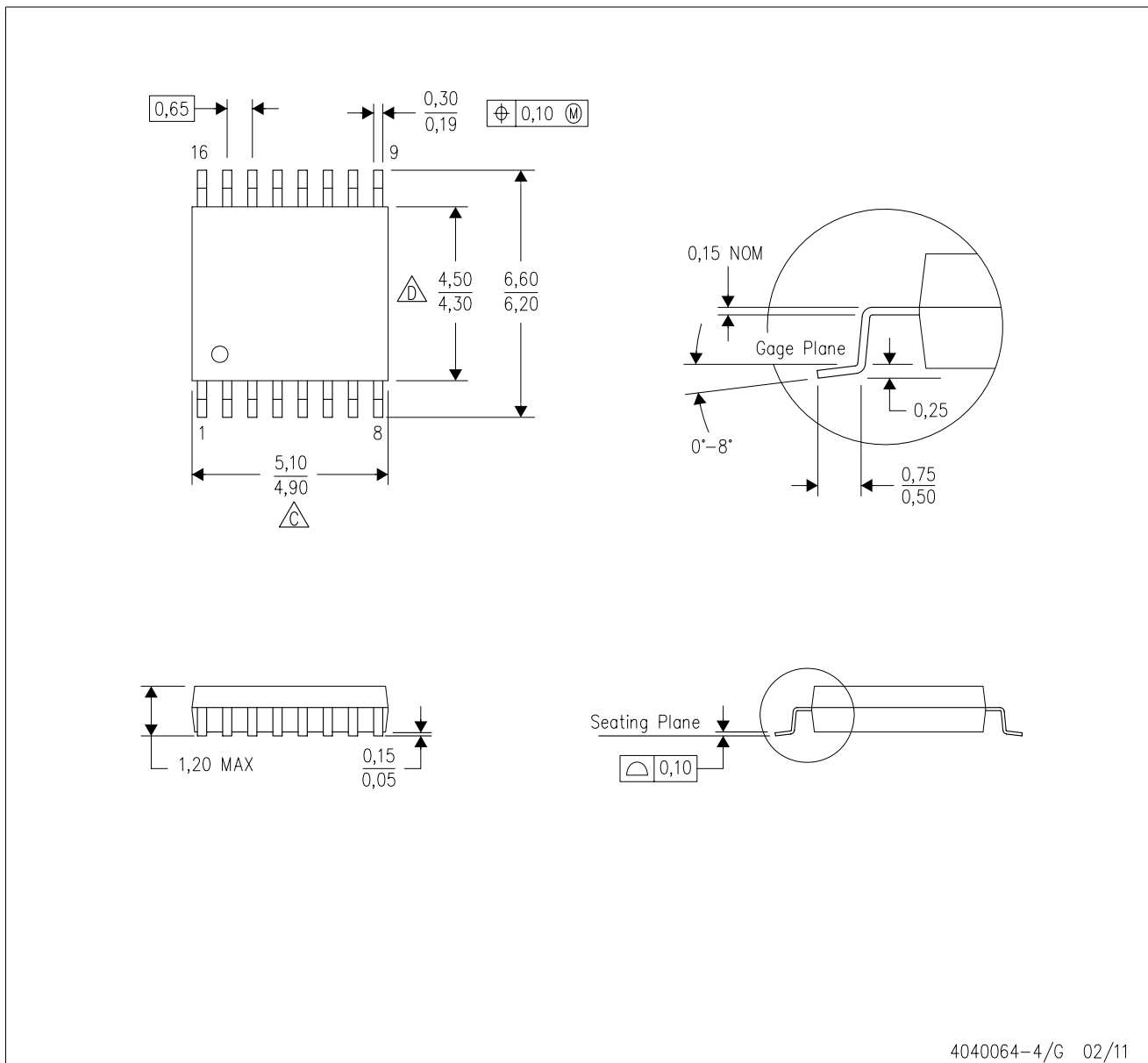

4040064-4/G 02/11

- NOTES:
- A. All linear dimensions are in millimeters. Dimensioning and tolerancing per ASME Y14.5M-1994.
 - B. This drawing is subject to change without notice.
 - C. Body length does not include mold flash, protrusions, or gate burrs. Mold flash, protrusions, or gate burrs shall not exceed 0,15 each side.
 - D. Body width does not include interlead flash. Interlead flash shall not exceed 0,25 each side.
 - E. Falls within JEDEC MO-153

RLL (S-PVQFN-N24)

PLASTIC QUAD FLATPACK NO-LEAD

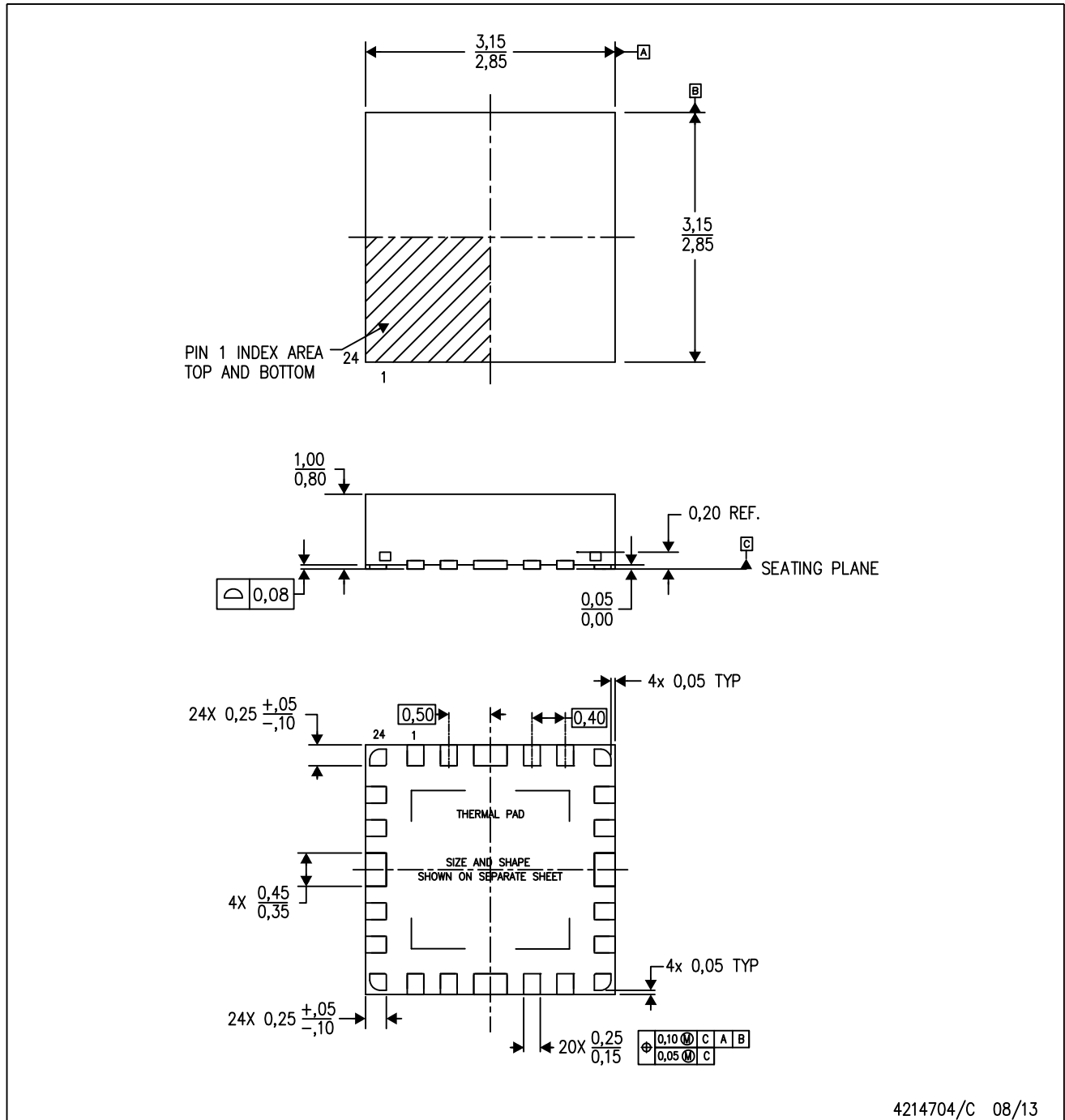

4214704/C 08/13

- NOTES:
- A. All linear dimensions are in millimeters. Dimensioning and tolerancing per ASME Y14.5M-1994.
 - B. This drawing is subject to change without notice.
 - C. Quad Flatpack, No-leads (QFN) package configuration.
 - D. The package thermal pad must be soldered to the board for thermal and mechanical performance.
 - E. See the additional figure in the Product Data Sheet for details regarding the exposed thermal pad features and dimensions.

THERMAL PAD MECHANICAL DATA

RLL (S-PVQFN-N24)

PLASTIC QUAD FLATPACK NO-LEAD

THERMAL INFORMATION

This package incorporates an exposed thermal pad that is designed to be attached directly to an external heatsink. The thermal pad must be soldered directly to the printed circuit board (PCB). After soldering, the PCB can be used as a heatsink. In addition, through the use of thermal vias, the thermal pad can be attached directly to the appropriate copper plane shown in the electrical schematic for the device, or alternatively, can be attached to a special heatsink structure designed into the PCB. This design optimizes the heat transfer from the integrated circuit (IC).

For information on the Quad Flatpack No-Lead (QFN) package and its advantages, refer to Application Report, QFN/SON PCB Attachment, Texas Instruments Literature No. SLUA271. This document is available at www.ti.com.

The exposed thermal pad dimensions for this package are shown in the following illustration.

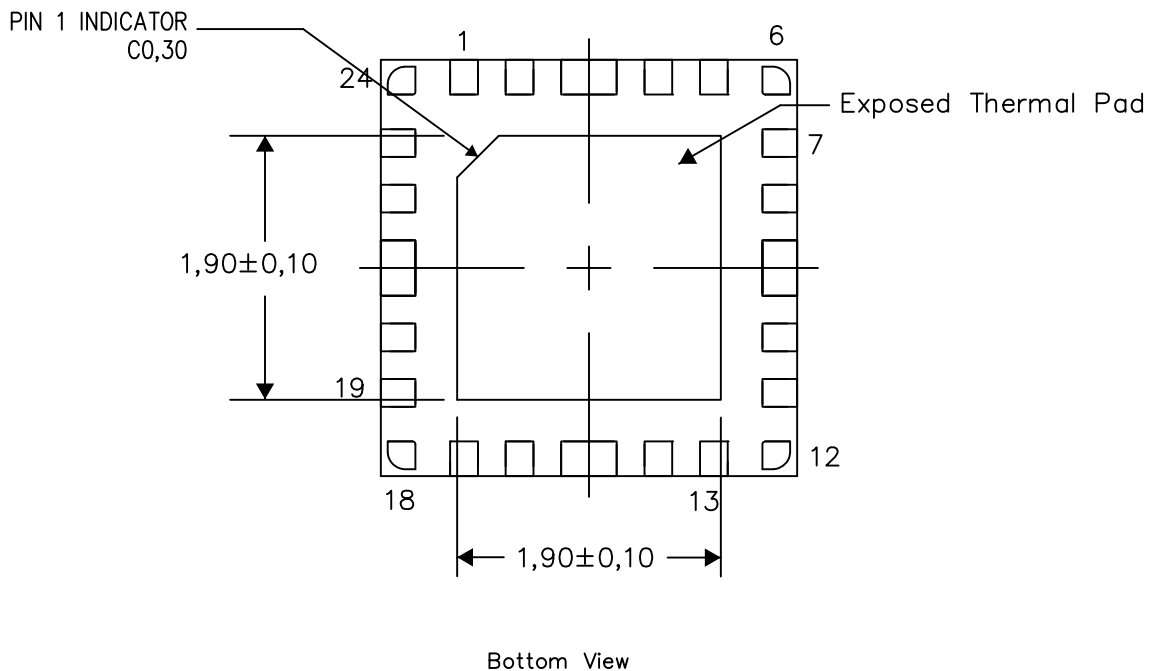

Exposed Thermal Pad Dimensions

4214706/D 08/13

NOTE: All linear dimensions are in millimeters

IMPORTANT NOTICE

Texas Instruments Incorporated and its subsidiaries (TI) reserve the right to make corrections, enhancements, improvements and other changes to its semiconductor products and services per JESD46, latest issue, and to discontinue any product or service per JESD48, latest issue. Buyers should obtain the latest relevant information before placing orders and should verify that such information is current and complete. All semiconductor products (also referred to herein as "components") are sold subject to TI's terms and conditions of sale supplied at the time of order acknowledgment.

TI warrants performance of its components to the specifications applicable at the time of sale, in accordance with the warranty in TI's terms and conditions of sale of semiconductor products. Testing and other quality control techniques are used to the extent TI deems necessary to support this warranty. Except where mandated by applicable law, testing of all parameters of each component is not necessarily performed.

TI assumes no liability for applications assistance or the design of Buyers' products. Buyers are responsible for their products and applications using TI components. To minimize the risks associated with Buyers' products and applications, Buyers should provide adequate design and operating safeguards.

TI does not warrant or represent that any license, either express or implied, is granted under any patent right, copyright, mask work right, or other intellectual property right relating to any combination, machine, or process in which TI components or services are used. Information published by TI regarding third-party products or services does not constitute a license to use such products or services or a warranty or endorsement thereof. Use of such information may require a license from a third party under the patents or other intellectual property of the third party, or a license from TI under the patents or other intellectual property of TI.

Reproduction of significant portions of TI information in TI data books or data sheets is permissible only if reproduction is without alteration and is accompanied by all associated warranties, conditions, limitations, and notices. TI is not responsible or liable for such altered documentation. Information of third parties may be subject to additional restrictions.

Resale of TI components or services with statements different from or beyond the parameters stated by TI for that component or service voids all express and any implied warranties for the associated TI component or service and is an unfair and deceptive business practice. TI is not responsible or liable for any such statements.

Buyer acknowledges and agrees that it is solely responsible for compliance with all legal, regulatory and safety-related requirements concerning its products, and any use of TI components in its applications, notwithstanding any applications-related information or support that may be provided by TI. Buyer represents and agrees that it has all the necessary expertise to create and implement safeguards which anticipate dangerous consequences of failures, monitor failures and their consequences, lessen the likelihood of failures that might cause harm and take appropriate remedial actions. Buyer will fully indemnify TI and its representatives against any damages arising out of the use of any TI components in safety-critical applications.

In some cases, TI components may be promoted specifically to facilitate safety-related applications. With such components, TI's goal is to help enable customers to design and create their own end-product solutions that meet applicable functional safety standards and requirements. Nonetheless, such components are subject to these terms.

No TI components are authorized for use in FDA Class III (or similar life-critical medical equipment) unless authorized officers of the parties have executed a special agreement specifically governing such use.

Only those TI components which TI has specifically designated as military grade or "enhanced plastic" are designed and intended for use in military/aerospace applications or environments. Buyer acknowledges and agrees that any military or aerospace use of TI components which have **not** been so designated is solely at the Buyer's risk, and that Buyer is solely responsible for compliance with all legal and regulatory requirements in connection with such use.

TI has specifically designated certain components as meeting ISO/TS16949 requirements, mainly for automotive use. In any case of use of non-designated products, TI will not be responsible for any failure to meet ISO/TS16949.

Products

Audio	www.ti.com/audio
Amplifiers	amplifier.ti.com
Data Converters	dataconverter.ti.com
DLP® Products	www.dlp.com
DSP	dsp.ti.com
Clocks and Timers	www.ti.com/clocks
Interface	interface.ti.com
Logic	logic.ti.com
Power Mgmt	power.ti.com
Microcontrollers	microcontroller.ti.com
RFID	www.ti-rfid.com
OMAP Applications Processors	www.ti.com/omap
Wireless Connectivity	www.ti.com/wirelessconnectivity

Applications

Automotive and Transportation	www.ti.com/automotive
Communications and Telecom	www.ti.com/communications
Computers and Peripherals	www.ti.com/computers
Consumer Electronics	www.ti.com/consumer-apps
Energy and Lighting	www.ti.com/energy
Industrial	www.ti.com/industrial
Medical	www.ti.com/medical
Security	www.ti.com/security
Space, Avionics and Defense	www.ti.com/space-avionics-defense
Video and Imaging	www.ti.com/video

TI E2E Community

e2e.ti.com