

DS36954 Quad Differential Bus Transceiver

 Check for Samples: [DS36954](#)

FEATURES

- Pinout for SCSI Interface
- Compact 20-Pin PLCC or SOIC Package
- Meets EIA-485 Standard for Multipoint Bus Transmission
- Greater than 60 mA Source/Sink Currents
- Thermal Shutdown Protection
- Glitch-Free Driver Outputs on Power Up and Down

DESCRIPTION

The DS36954 is a low power, quad EIA-485 differential bus transceiver especially suited for high speed, parallel, multipoint, I/O bus applications. A compact 20-pin surface mount PLCC or SOIC package provides high transceiver integration and a very small PC board footprint.

Propagation delay skew between devices is specified to aid in parallel interface designs—limits on maximum and minimum delay times are verified.

Five devices can implement a complete SCSI initiator or target interface. Three transceivers in a package are pinned out for data bus connections. The fourth transceiver, with the flexibility provided by its individual enables, can serve as a control bus transceiver.

Connection Diagram

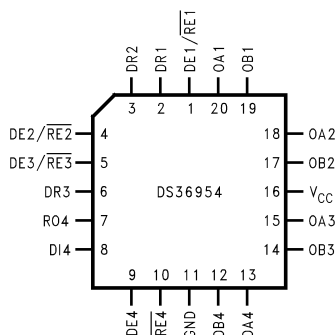

See Package Number FN (S-PQCC-J20)

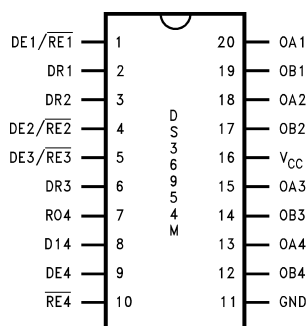

See Package Number DW (R-PDSO-G20)

Logic Diagram

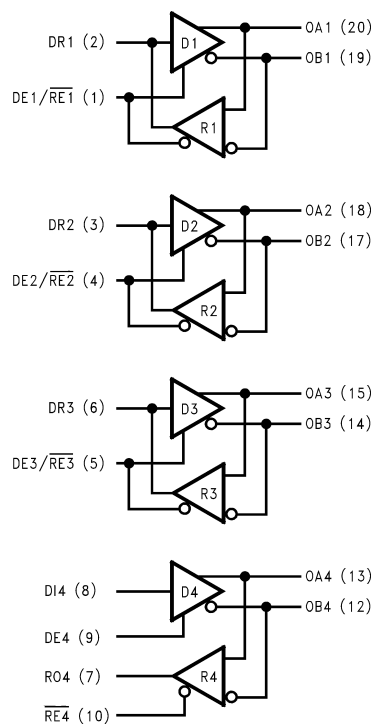

Please be aware that an important notice concerning availability, standard warranty, and use in critical applications of Texas Instruments semiconductor products and disclaimers thereto appears at the end of this data sheet.

All trademarks are the property of their respective owners.



These devices have limited built-in ESD protection. The leads should be shorted together or the device placed in conductive foam during storage or handling to prevent electrostatic damage to the MOS gates.

Absolute Maximum Ratings ⁽¹⁾⁽²⁾

Supply Voltage	7V
Control Input Voltage	$V_{CC} + 0.5V$
Driver Input Voltage	$V_{CC} + 0.5V$
Driver Output Voltage/Receiver Input Voltage	-10V to +15V
Receiver Output Voltage	5.5V
Continuous Power Dissipation @ +25°C	
FN Package	1.73W
DW Package	1.73W
Derate FN Package	13.9 mW/°C above +25°C
Derate DW Package	13.7 mW/°C above +25°C
Storage Temperature Range	-65°C to +150°C
Lead Temperature (Soldering 4 Sec.)	260°C

- (1) "Absolute Maximum Ratings" are those values beyond which the safety of the device cannot be verified. They are not meant to imply that the devices should be operated at these limits. The tables of "Electrical Characteristics" specify conditions for device operation.
- (2) If Military/Aerospace specified devices are required, please contact the Texas Instrument Sales Office/ Distributors for availability and specifications.

Recommended Operating Conditions

	Min	Max	Units
Supply Voltage, V_{CC}	4.75	5.25	V
Bus Voltage	-7	+12	V
Operating Free Air Temperature (T_A)	0	+70	°C

Electrical Characteristics ⁽¹⁾⁽²⁾

Over Supply Voltage and Operating Temperature ranges, unless otherwise specified

Symbol	Parameter	Conditions	Min	Typ	Max	Units
DRIVER CHARACTERISTICS						
V_{ODL}	Differential Driver Output Voltage (Full Load)	$I_L = 60 \text{ mA}$ $V_{CM} = 0V$	1.5	1.9		V
V_{OD}	Differential Driver Output Voltage (Termination Load)	$R_L = 100\Omega$ (EIA-422) $R_L = 54\Omega$ (EIA-485)	2.0 1.5	2.25 2.0		V
$\Delta IVODI$	Change in Magnitude of Driver Differential Output Voltage for Complementary Output States	$R_L = 54$ or 100Ω ⁽³⁾ (Figure 1) (EIA-422/485)			0.2	V
V_{OC}	Driver Common Mode Output Voltage ⁽⁴⁾	$R_L = 54\Omega$ (Figure 1) (EIA-485)			3.0	V
$\Delta IVOCI$	Change in Magnitude of Common Mode Output Voltage	⁽³⁾ (Figure 1) (EIA-422/485)			0.2	V
V_{OH}	Output Voltage High	$I_{OH} = -55 \text{ mA}$	2.7	3.2		V
V_{OL}	Output Voltage Low	$I_{OL} = 55 \text{ mA}$		1.4	1.7	V
V_{IH}	Input Voltage High		2.0			V
V_{IL}	Input Voltage Low				0.8	V
V_{CL}	Input Clamp Voltage	$I_{CL} = -18 \text{ mA}$			-1.5	V

- (1) Current into device pins is defined as positive. Current out of device pins is defined as negative. All voltages are referenced to ground unless otherwise specified.
- (2) All typicals are given for $V_{CC} = 5V$ and $T_A = 25^\circ\text{C}$.
- (3) $\Delta IVODI$ and $\Delta IVOCI$ are changes in magnitude of V_{OD} and V_{OC} , respectively, that occur when the input changes state.
- (4) In EIA Standards EIA-422 and EIA-485, V_{OC} , which is the average of the two output voltages with respect to ground, is called output offset voltage, V_{OS} .

Electrical Characteristics ⁽¹⁾⁽²⁾ (continued)

Over Supply Voltage and Operating Temperature ranges, unless otherwise specified

Symbol	Parameter	Conditions	Min	Typ	Max	Units
I_{IH}	Input High Current	$V_{IN} = 2.4V$ ⁽⁵⁾			20	μA
I_{IL}	Input Low Current	$V_{IN} = 0.4V$ ⁽⁵⁾			-20	μA
I_{OSC}	Driver Short-Circuit Output Current ⁽⁶⁾	$V_O = -7V$ (EIA-485)		-130	-250	mA
		$V_O = 0V$ (EIA-422)		-90	-150	mA
		$V_O = +12V$ (EIA-485)		130	250	mA
RECEIVER CHARACTERISTICS						
I_{OSR}	Short Circuit Output Current	$V_O = 0V$ ⁽⁶⁾	-15	-28	-75	mA
I_{OZ}	TRI-STATE Output Current	$V_O = 0.4V$ to $2.4V$			20	μA
V_{OH}	Output Voltage High	$V_{ID} = 0.2V$, $I_{OH} = 0.4$ mA	2.4	3.0		V
V_{OL}	Output Voltage Low	$V_{ID} = -0.2V$, $I_{OL} = 4$ mA		0.35	0.5	V
V_{TH}	Differential Input High Threshold Voltage	$V_O = V_{OH}$, $I_O = -0.4$ mA (EIA-422/485)		0.03	0.2	V
V_{TL}	Differential Input Low Threshold Voltage ⁽⁷⁾	$V_O = V_{OL}$, $I_O = 4.0$ mA (EIA-422/485)	-0.2 0	-0.03		V
V_{HST}	Hysteresis ⁽⁸⁾	$V_{CM} = 0V$	35	60		mV
DRIVER AND RECEIVER CHARACTERISTICS						
V_{IH}	Enable Input Voltage High		2.0			V
V_{IL}	Enable Input Voltage Low				0.8	V
V_{CL}	Enable Input Clamp Voltage	$I_{CL} = -18$ mA			-1.5	V
I_{IN}	Line Input Current ⁽⁹⁾	Other Input = 0V DE/RE = 0.8V DE4 = 0.8V	$V_I = +12V$	0.5	1.0	mA
			$V_I = -7V$	-0.45	-0.8	mA
I_{ING}	Line Input Current ⁽⁹⁾	Other Input = 0V DE/RE and DE4 = 2V $V_{CC} = 3.0V$ $T_A = +25^\circ C$	$V_I = +12V$		1.0	mA
			$V_I = -7V$		-0.8	mA
I_{IH}	Enable Input Current High	$V_{IN} = 2.4V$ DE/RE	$V_{CC} = 3.0V$	1	40	μA
			$V_{CC} = 4.75V$	1		μA
			$V_{CC} = 5.25V$	1	40	μA
		$V_{IN} = 2.4V$ DE4 or RE4	$V_{CC} = 3.0V$	1	20	μA
			$V_{CC} = 5.25V$	1	20	μA
I_{IL}	Enable Input Current Low	$V_{IN} = 0.8V$ DE/RE	$V_{CC} = 3.0V$	-6	-40	μA
			$V_{CC} = 4.75V$	-12		μA
			$V_{CC} = 5.25V$	-14	-40	μA
		$V_{IN} = 0.8V$ DE4 or RE4	$V_{CC} = 3.0V$	-3	-20	μA
			$V_{CC} = 5.25V$	-7	-20	μA
I_{CCD}	Supply Current ⁽¹⁰⁾	No Load, DE/RE and DE4 = 2.0V		75	90	mA
I_{CCR}	Supply Current ⁽¹⁰⁾	No Load, DE/RE and RE4 = 0.8V		50	70	mA

(5) I_{IH} and I_{IL} include driver input current and receiver TRI-STATE leakage current on DR(1–3).

(6) Short one output at a time.

(7) Threshold parameter limits specified as an algebraic value rather than by magnitude.

(8) Hysteresis defined as $V_{HST} = V_{TH} - V_{TL}$.

(9) I_{IN} includes the receiver input current and driver TRI-STATE leakage current.

(10) Total package supply current.

Switching Characteristics

Over Supply Voltage and Operating Temperature ranges, unless otherwise specified.

Symbol	Parameter	Conditions	Min	Typ	Max	Units	
DRIVER SINGLE-ENDED CHARACTERISTICS							
t_{PZH}	Output Enable Time to High Level	$R_L = 110\Omega$ (Figure 6)		35	40	ns	
t_{PZL}	Output Enable Time to Low Level		(Figure 8)	25	40	ns	
t_{PHZ}	Output Disable Time to High Level		(Figure 6)		15	25	ns
t_{PLZ}	Output Disable Time to Low Level		(Figure 8)		35	40	ns
DRIVER DIFFERENTIAL CHARACTERISTICS							
t_r, t_f	Rise and Fall Time	$R_L = 54\Omega$ $C_L = 50\text{ pF}$ $C_D = 15\text{ pF}$ (Figure 3 Figure 4 ⁽¹⁾)		13	16	ns	
t_{PLHD}	Differential Propagation		9	15	19	ns	
t_{PHLD}	Delays ⁽²⁾		9	12	19	ns	
t_{SKD}	$ t_{PLHD} - t_{PHLD} $ Diff. Skew			3	6	ns	
RECEIVER CHARACTERISTICS							
t_{PLHD}	Differential Propagation Delays	$C_L = 15\text{ pF}$ $V_{CM} = 2.0V$ (Figure 10)	9	14	19	ns	
t_{PHLD}			9	13	19	ns	
t_{SKD}	$ t_{PLHD} - t_{PHLD} $ Diff. Receiver Skew			1	3	ns	
t_{PZH}	Output Enable Time to High Level	$C_L = 15\text{ pF}$ (Figure 15)		15	22	ns	
t_{PZL}	Output Enable Time to Low Level			20	30	ns	
t_{PHZ}	Output Disable Time from High Level			20	30	ns	
t_{PLZ}	Output Disable Time from Low Level			17	25	ns	

(1) Propagation Delay Timing for Calculations of Driver Differential Propagation Delays

(2) Differential propagation delays are calculated from single-ended propagation delays measured from driver input to the 20% and 80% levels on the driver outputs (Figure 16) .

PARAMETER MEASUREMENT INFORMATION

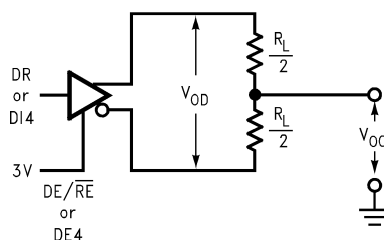

Figure 1. Driver V_{OD} and V_{OC} ⁽³⁾

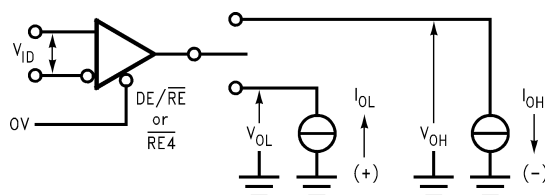
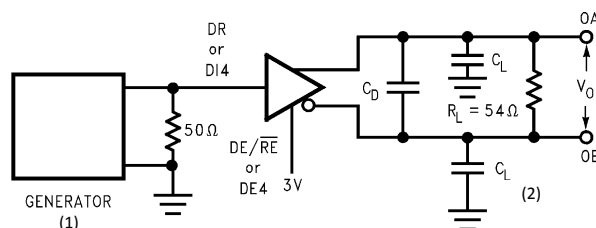
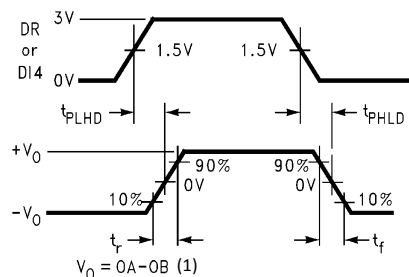

Figure 2. Receiver V_{OH} and V_{OL}



- (1) The input pulse is supplied by a generator having the following characteristics: $f = 1.0$ MHz, 50% duty cycle, $\text{trand} \text{tf} < 6.0$ ns, $Z_0 = 50\Omega$
- (2) C_L includes probe and stray capacitance.

Figure 3. Driver Differential Propagation Delay Load Circuit



- (1) Differential propagation delays are calculated from single-ended propagation delays measured from driver input to the 20% and 80% levels on the driver outputs (Figure 16).

Figure 4. Driver Differential Propagation Delays and Transition Times

(3) C_L includes probe and stray capacitance.

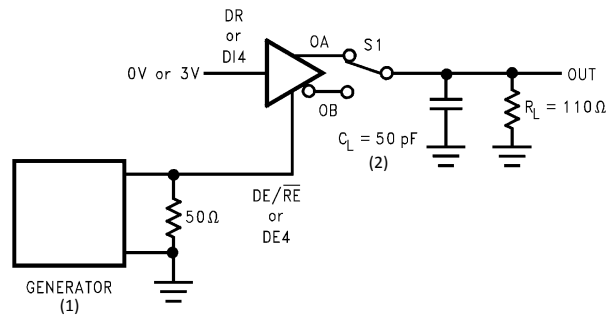

S1 to OA for DI = 3V

S1 to OB for DI = 0V

- (1) The input pulse is supplied by a generator having the following characteristics: $f = 1.0$ MHz, 50% duty cycle, $\text{trand} \text{tf} < 6.0$ ns, $Z_O = 50\Omega$.
- (2) C_L includes probe and stray capacitance.

Figure 5.

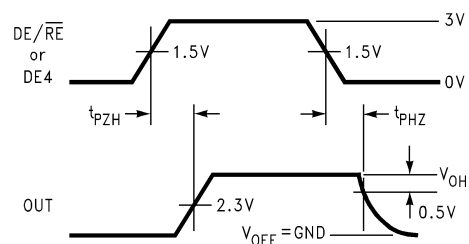
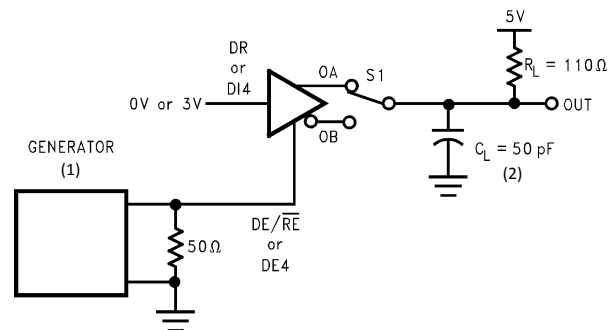

Figure 6. Driver Enable and Disable Timing (t_{PZH} , t_{PHZ})



S1 to OA for DI = 0V

S1 to OB for DI = 3V

- (1) The input pulse is supplied by a generator having the following characteristics: $f = 1.0$ MHz, 50% duty cycle, $\text{trand} \text{tf} < 6.0$ ns, $Z_O = 50\Omega$.
- (2) C_L includes probe and stray capacitance.

Figure 7.

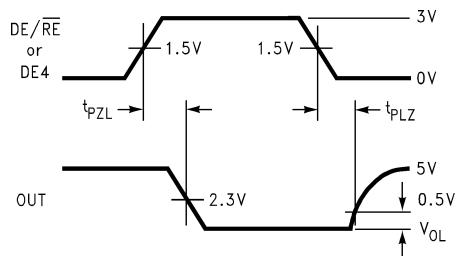
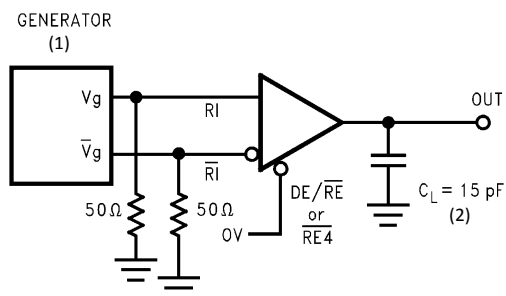

Figure 8. Driver Enable and Disable Timing (t_{PZL} , t_{PLZ})



- (1) The input pulse is supplied by a generator having the following characteristics: $f = 1.0$ MHz, 50% duty cycle, $\text{trand} \leq 6.0$ ns, $Z_0 = 50\Omega$.
- (2) C_L includes probe and stray capacitance.

Figure 9.

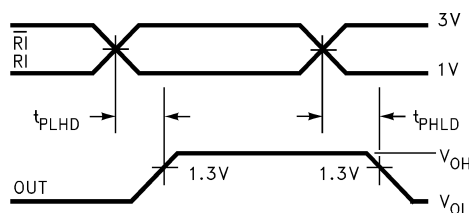
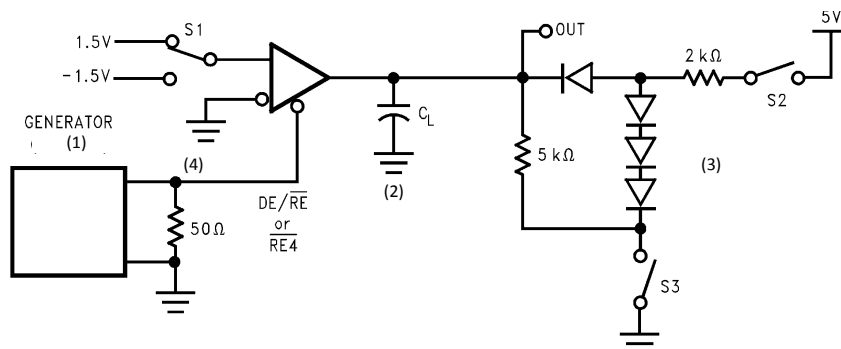
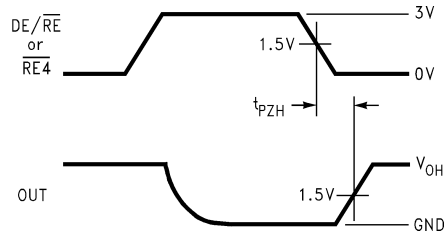

Figure 10. Receiver Differential Propagation Delay Timing



- (1) The input pulse is supplied by a generator having the following characteristics: $f = 1.0$ MHz, 50% duty cycle, $\text{trand} \leq 6.0$ ns, $Z_0 = 50\Omega$.
- (2) C_L includes probe and stray capacitance.
- (3) Diodes are 1N916 or equivalent.
- (4) On transceivers 1–3 the driver is loaded with receiver input conditions when DE/RE is high. Do not exceed the package power dissipation limit when testing.

Figure 11.



S1 1.5V
S2 Open
S3 Closed

Figure 12.

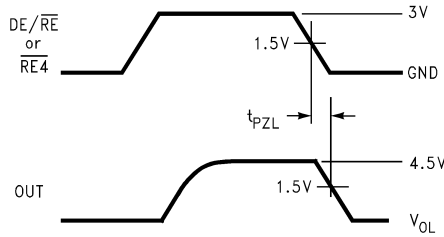

S1 -1.5V
S2 Closed
C3 Open

Figure 13.

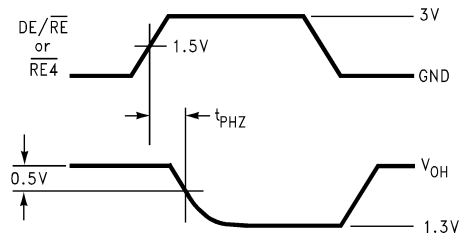

S1 1.5V
S2 Closed
C3 Closed

Figure 14.

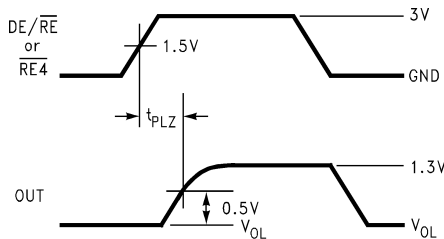

S1 -1.5V
S2 Closed
C3 Closed

Figure 15. Receiver Enable and Disable Timing

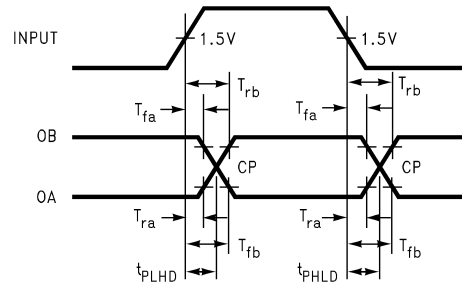

$$T_{CP} = \frac{(T_{fb} \times T_{rb}) - (T_{ra} \times T_{fa})}{T_{rb} - T_{ra} - T_{fa} + T_{fb}}$$

T_{ra} , T_{rb} , T_{fa} and T_{fb} are propagation delay measurements to the 20% and 80% levels.

T_{CP} = Crossing Point

Figure 16. Propagation Delay Timing for Calculations of Driver Differential Propagation Delays

REVISION HISTORY

Changes from Revision B (April 2013) to Revision C	Page
• Changed layout of National Data Sheet to TI format	9

PACKAGING INFORMATION

Orderable Device	Status (1)	Package Type	Package Drawing	Pins	Package Qty	Eco Plan (2)	Lead/Ball Finish (6)	MSL Peak Temp (3)	Op Temp (°C)	Device Marking (4/5)	Samples
DS36954M/NOPB	ACTIVE	SOIC	DW	20	36	Green (RoHS & no Sb/Br)	CU SN	Level-3-260C-168 HR	0 to 70	DS36954 M	Samples
DS36954MX/NOPB	ACTIVE	SOIC	DW	20	1000	Green (RoHS & no Sb/Br)	CU SN	Level-3-260C-168 HR	0 to 70	DS36954 M	Samples
DS36954VX/NOPB	ACTIVE	PLCC	FN	20	1000	Green (RoHS & no Sb/Br)	CU SN	Level-2A-250C-4 WEEK	0 to 70	DS36954V	Samples

(1) The marketing status values are defined as follows:

ACTIVE: Product device recommended for new designs.

LIFEBUY: TI has announced that the device will be discontinued, and a lifetime-buy period is in effect.

NRND: Not recommended for new designs. Device is in production to support existing customers, but TI does not recommend using this part in a new design.

PREVIEW: Device has been announced but is not in production. Samples may or may not be available.

OBsolete: TI has discontinued the production of the device.

(2) Eco Plan - The planned eco-friendly classification: Pb-Free (RoHS), Pb-Free (RoHS Exempt), or Green (RoHS & no Sb/Br) - please check <http://www.ti.com/productcontent> for the latest availability information and additional product content details.

TBD: The Pb-Free/Green conversion plan has not been defined.

Pb-Free (RoHS): TI's terms "Lead-Free" or "Pb-Free" mean semiconductor products that are compatible with the current RoHS requirements for all 6 substances, including the requirement that lead not exceed 0.1% by weight in homogeneous materials. Where designed to be soldered at high temperatures, TI Pb-Free products are suitable for use in specified lead-free processes.

Pb-Free (RoHS Exempt): This component has a RoHS exemption for either 1) lead-based flip-chip solder bumps used between the die and package, or 2) lead-based die adhesive used between the die and leadframe. The component is otherwise considered Pb-Free (RoHS compatible) as defined above.

Green (RoHS & no Sb/Br): TI defines "Green" to mean Pb-Free (RoHS compatible), and free of Bromine (Br) and Antimony (Sb) based flame retardants (Br or Sb do not exceed 0.1% by weight in homogeneous material)

(3) MSL, Peak Temp. - The Moisture Sensitivity Level rating according to the JEDEC industry standard classifications, and peak solder temperature.

(4) There may be additional marking, which relates to the logo, the lot trace code information, or the environmental category on the device.

(5) Multiple Device Markings will be inside parentheses. Only one Device Marking contained in parentheses and separated by a "~" will appear on a device. If a line is indented then it is a continuation of the previous line and the two combined represent the entire Device Marking for that device.

(6) Lead/Ball Finish - Orderable Devices may have multiple material finish options. Finish options are separated by a vertical ruled line. Lead/Ball Finish values may wrap to two lines if the finish value exceeds the maximum column width.

Important Information and Disclaimer: The information provided on this page represents TI's knowledge and belief as of the date that it is provided. TI bases its knowledge and belief on information provided by third parties, and makes no representation or warranty as to the accuracy of such information. Efforts are underway to better integrate information from third parties. TI has taken and

continues to take reasonable steps to provide representative and accurate information but may not have conducted destructive testing or chemical analysis on incoming materials and chemicals. TI and TI suppliers consider certain information to be proprietary, and thus CAS numbers and other limited information may not be available for release.

In no event shall TI's liability arising out of such information exceed the total purchase price of the TI part(s) at issue in this document sold by TI to Customer on an annual basis.

TAPE AND REEL INFORMATION



QUADRANT ASSIGNMENTS FOR PIN 1 ORIENTATION IN TAPE



*All dimensions are nominal

Device	Package Type	Package Drawing	Pins	SPQ	Reel Diameter (mm)	Reel Width W1 (mm)	A0 (mm)	B0 (mm)	K0 (mm)	P1 (mm)	W (mm)	Pin1 Quadrant
DS36954MX/NOPB	SOIC	DW	20	1000	330.0	24.4	10.9	13.3	3.25	12.0	24.0	Q1

TAPE AND REEL BOX DIMENSIONS



*All dimensions are nominal

Device	Package Type	Package Drawing	Pins	SPQ	Length (mm)	Width (mm)	Height (mm)
DS36954MX/NOPB	SOIC	DW	20	1000	367.0	367.0	45.0

FN (S-PQCC-J**)

PLASTIC J-LEADED CHIP CARRIER

20 PIN SHOWN

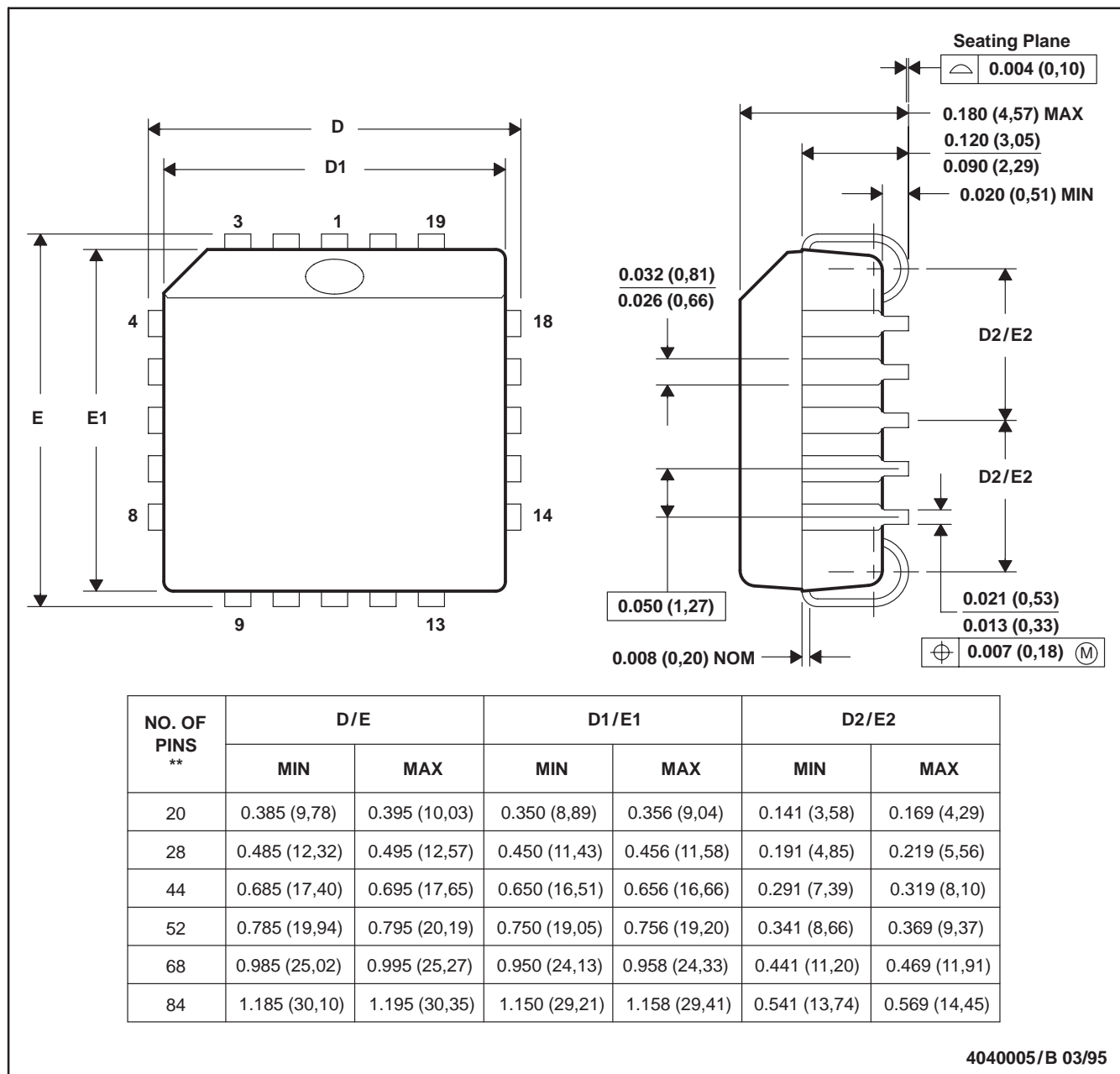

- NOTES: A. All linear dimensions are in inches (millimeters).
 B. This drawing is subject to change without notice.
 C. Falls within JEDEC MS-018

DW0020A



PACKAGE OUTLINE

SOIC - 2.65 mm max height

SOIC



NOTES:

1. All linear dimensions are in millimeters. Dimensions in parenthesis are for reference only. Dimensioning and tolerancing per ASME Y14.5M.
2. This drawing is subject to change without notice.
3. This dimension does not include mold flash, protrusions, or gate burrs. Mold flash, protrusions, or gate burrs shall not exceed 0.15 mm per side.
4. This dimension does not include interlead flash. Interlead flash shall not exceed 0.43 mm per side.
5. Reference JEDEC registration MS-013.

EXAMPLE BOARD LAYOUT

DW0020A

SOIC - 2.65 mm max height

SOIC



LAND PATTERN EXAMPLE
SCALE:6X



SOLDER MASK DETAILS

4220724/A 05/2016

NOTES: (continued)

- 6. Publication IPC-7351 may have alternate designs.
- 7. Solder mask tolerances between and around signal pads can vary based on board fabrication site.

EXAMPLE STENCIL DESIGN

DW0020A

SOIC - 2.65 mm max height

SOIC

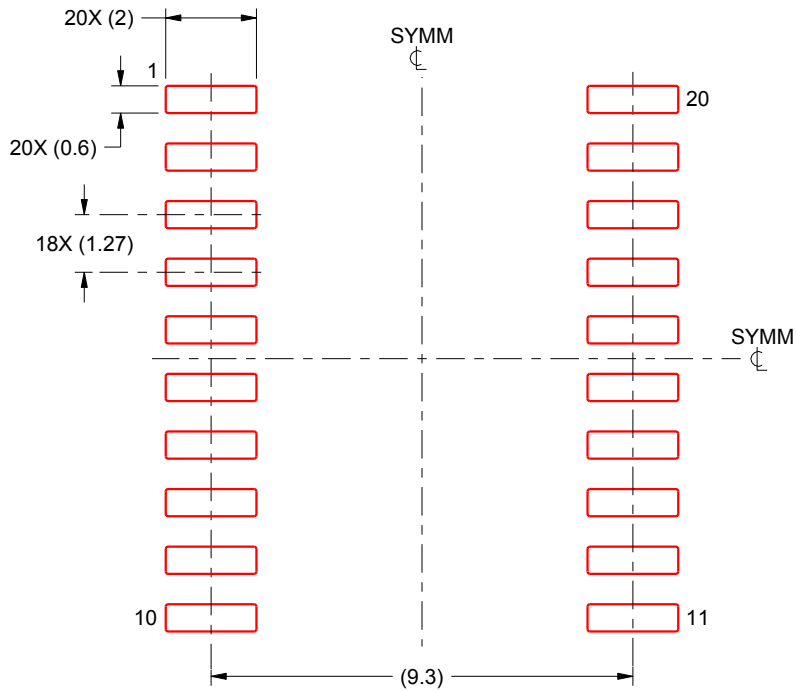

SOLDER PASTE EXAMPLE
BASED ON 0.125 mm THICK STENCIL
SCALE:6X

4220724/A 05/2016

NOTES: (continued)

8. Laser cutting apertures with trapezoidal walls and rounded corners may offer better paste release. IPC-7525 may have alternate design recommendations.
9. Board assembly site may have different recommendations for stencil design.

IMPORTANT NOTICE

Texas Instruments Incorporated (TI) reserves the right to make corrections, enhancements, improvements and other changes to its semiconductor products and services per JESD46, latest issue, and to discontinue any product or service per JESD48, latest issue. Buyers should obtain the latest relevant information before placing orders and should verify that such information is current and complete.

TI's published terms of sale for semiconductor products (<http://www.ti.com/sc/docs/stdterms.htm>) apply to the sale of packaged integrated circuit products that TI has qualified and released to market. Additional terms may apply to the use or sale of other types of TI products and services.

Reproduction of significant portions of TI information in TI data sheets is permissible only if reproduction is without alteration and is accompanied by all associated warranties, conditions, limitations, and notices. TI is not responsible or liable for such reproduced documentation. Information of third parties may be subject to additional restrictions. Resale of TI products or services with statements different from or beyond the parameters stated by TI for that product or service voids all express and any implied warranties for the associated TI product or service and is an unfair and deceptive business practice. TI is not responsible or liable for any such statements.

Buyers and others who are developing systems that incorporate TI products (collectively, "Designers") understand and agree that Designers remain responsible for using their independent analysis, evaluation and judgment in designing their applications and that Designers have full and exclusive responsibility to assure the safety of Designers' applications and compliance of their applications (and of all TI products used in or for Designers' applications) with all applicable regulations, laws and other applicable requirements. Designer represents that, with respect to their applications, Designer has all the necessary expertise to create and implement safeguards that (1) anticipate dangerous consequences of failures, (2) monitor failures and their consequences, and (3) lessen the likelihood of failures that might cause harm and take appropriate actions. Designer agrees that prior to using or distributing any applications that include TI products, Designer will thoroughly test such applications and the functionality of such TI products as used in such applications.

TI's provision of technical, application or other design advice, quality characterization, reliability data or other services or information, including, but not limited to, reference designs and materials relating to evaluation modules, (collectively, "TI Resources") are intended to assist designers who are developing applications that incorporate TI products; by downloading, accessing or using TI Resources in any way, Designer (individually or, if Designer is acting on behalf of a company, Designer's company) agrees to use any particular TI Resource solely for this purpose and subject to the terms of this Notice.

TI's provision of TI Resources does not expand or otherwise alter TI's applicable published warranties or warranty disclaimers for TI products, and no additional obligations or liabilities arise from TI providing such TI Resources. TI reserves the right to make corrections, enhancements, improvements and other changes to its TI Resources. TI has not conducted any testing other than that specifically described in the published documentation for a particular TI Resource.

Designer is authorized to use, copy and modify any individual TI Resource only in connection with the development of applications that include the TI product(s) identified in such TI Resource. NO OTHER LICENSE, EXPRESS OR IMPLIED, BY ESTOPPEL OR OTHERWISE TO ANY OTHER TI INTELLECTUAL PROPERTY RIGHT, AND NO LICENSE TO ANY TECHNOLOGY OR INTELLECTUAL PROPERTY RIGHT OF TI OR ANY THIRD PARTY IS GRANTED HEREIN, including but not limited to any patent right, copyright, mask work right, or other intellectual property right relating to any combination, machine, or process in which TI products or services are used. Information regarding or referencing third-party products or services does not constitute a license to use such products or services, or a warranty or endorsement thereof. Use of TI Resources may require a license from a third party under the patents or other intellectual property of the third party, or a license from TI under the patents or other intellectual property of TI.

TI RESOURCES ARE PROVIDED "AS IS" AND WITH ALL FAULTS. TI DISCLAIMS ALL OTHER WARRANTIES OR REPRESENTATIONS, EXPRESS OR IMPLIED, REGARDING RESOURCES OR USE THEREOF, INCLUDING BUT NOT LIMITED TO ACCURACY OR COMPLETENESS, TITLE, ANY EPIDEMIC FAILURE WARRANTY AND ANY IMPLIED WARRANTIES OF MERCHANTABILITY, FITNESS FOR A PARTICULAR PURPOSE, AND NON-INFRINGEMENT OF ANY THIRD PARTY INTELLECTUAL PROPERTY RIGHTS. TI SHALL NOT BE LIABLE FOR AND SHALL NOT DEFEND OR INDEMNIFY DESIGNER AGAINST ANY CLAIM, INCLUDING BUT NOT LIMITED TO ANY INFRINGEMENT CLAIM THAT RELATES TO OR IS BASED ON ANY COMBINATION OF PRODUCTS EVEN IF DESCRIBED IN TI RESOURCES OR OTHERWISE. IN NO EVENT SHALL TI BE LIABLE FOR ANY ACTUAL, DIRECT, SPECIAL, COLLATERAL, INDIRECT, PUNITIVE, INCIDENTAL, CONSEQUENTIAL OR EXEMPLARY DAMAGES IN CONNECTION WITH OR ARISING OUT OF TI RESOURCES OR USE THEREOF, AND REGARDLESS OF WHETHER TI HAS BEEN ADVISED OF THE POSSIBILITY OF SUCH DAMAGES.

Unless TI has explicitly designated an individual product as meeting the requirements of a particular industry standard (e.g., ISO/TS 16949 and ISO 26262), TI is not responsible for any failure to meet such industry standard requirements.

Where TI specifically promotes products as facilitating functional safety or as compliant with industry functional safety standards, such products are intended to help enable customers to design and create their own applications that meet applicable functional safety standards and requirements. Using products in an application does not by itself establish any safety features in the application. Designers must ensure compliance with safety-related requirements and standards applicable to their applications. Designer may not use any TI products in life-critical medical equipment unless authorized officers of the parties have executed a special contract specifically governing such use. Life-critical medical equipment is medical equipment where failure of such equipment would cause serious bodily injury or death (e.g., life support, pacemakers, defibrillators, heart pumps, neurostimulators, and implantables). Such equipment includes, without limitation, all medical devices identified by the U.S. Food and Drug Administration as Class III devices and equivalent classifications outside the U.S.

TI may expressly designate certain products as completing a particular qualification (e.g., Q100, Military Grade, or Enhanced Product). Designers agree that it has the necessary expertise to select the product with the appropriate qualification designation for their applications and that proper product selection is at Designers' own risk. Designers are solely responsible for compliance with all legal and regulatory requirements in connection with such selection.

Designer will fully indemnify TI and its representatives against any damages, costs, losses, and/or liabilities arising out of Designer's non-compliance with the terms and provisions of this Notice.