

## FEATURES

- Operates With 3-V to 5.5-V  $V_{CC}$  Supply
- Operates up to 1 Mbit/s
- Low Supply Current . . . 300  $\mu$ A Typ
- External Capacitors . . .  $4 \times 0.1 \mu$ F
- Accept 5-V Logic Input With 3.3-V Supply
- Latch-Up Performance Exceeds 100 mA Per JESD 78, Class II
- ESD Protection for RS-232 Pins
  - $\pm 15$ -kV Human-Body Model (HBM)
  - $\pm 15$ -kV IEC 61000-4-2 Air-Gap Discharge
  - $\pm 8$ -kV IEC 61000-4-2 Contact Discharge

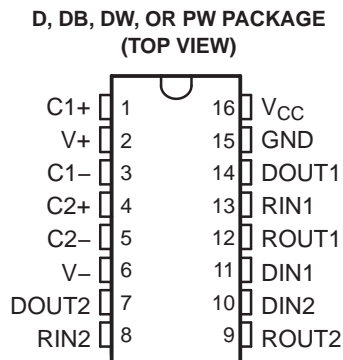

## APPLICATIONS

- Battery-Powered Systems
- PDAs
- Notebooks
- Laptops
- Palmtop PCs
- Hand-Held Equipment

## DESCRIPTION/ORDERING INFORMATION

The TRSF3232E consists of two line drivers, two line receivers, and a dual charge-pump circuit with  $\pm 15$ -kV ESD protection pin to pin (serial-port connection pins, including GND). This device provides the electrical interface between an asynchronous communication controller and the serial-port connector. The charge pump and four small external capacitors allow operation from a single 3-V to 5.5-V supply. The TRSF3232E operates at data signaling rates up to 1 Mbit/s and a driver output slew rate of 14 V/ $\mu$ s to 150 V/ $\mu$ s.

### ORDERING INFORMATION

$T_A$	PACKAGE <sup>(1)(2)</sup>		ORDERABLE PART NUMBER	TOP-SIDE MARKING
0°C to 70°C	SOIC – D	Tube of 40	TRSF3232ECD	TRSF3232EC
		Reel of 2500	TRSF3232ECDR	
	SOIC – DW	Tube of 40	TRSF3232ECDW	TRSF3232EC
		Reel of 2000	TRSF3232ECDWR	
	SSOP – DB	Reel of 2000	TRSF3232ECDBR	RT32EC
	TSSOP – PW	Tube of 90	TRSF3232ECPW	RT32EC
Reel of 2000		TRSF3232ECPWR		
–40°C to 85°C	SOIC – D	Tube of 40	TRSF3232EID	TRSF3232EI
		SOIC – DW	TRSF3232EIDR	
	SOIC – DW	Tube of 40	TRSF3232EIDW	TRSF3232EI
		TSSOP – PW	TRSF3232EIDWR	
	SSOP – DB	Reel of 2000	TRSF3232EIDBR	RT32EI
	TSSOP – PW	Tube of 90	TRSF3232EIPW	RT32EI
		Reel of 2000	TRSF3232EIPWR	

(1) Package drawings, thermal data, and symbolization are available at [www.ti.com/packaging](http://www.ti.com/packaging).

(2) For the most current package and ordering information, see the Package Option Addendum at the end of this document, or see the TI website at [www.ti.com](http://www.ti.com).



Please be aware that an important notice concerning availability, standard warranty, and use in critical applications of Texas Instruments semiconductor products and disclaimers thereto appears at the end of this data sheet.

**TRSF3232E**  
**3-V TO 5.5-V TWO-CHANNEL RS-232 1-Mbit/s LINE DRIVER/RECEIVER**  
**WITH  $\pm 15$ -kV IEC ESD PROTECTION**

SLLS825–AUGUST 2007

**Table 1. 1-Mbit/s RS-232 Parts**

TEMPERATURE RANGE	PART NO.	NO. OF DRIVERS	NO. OF RECEIVERS	ESD	SUPPLY $V_{CC}$ (V)	FEATURE	PIN/PACKAGE
0°C to 70°C	TRSF3221E	1	1	$\pm 15$ -kV Air-Gap Discharge, $\pm 8$ -kV Contact Discharge, $\pm 15$ -kV HBM	3.3 or 5	Auto-powerdown	16-pin SOIC, SSOP, TSSOP
	TRSF3232E	2	2	$\pm 15$ -kV Air-Gap Discharge, $\pm 8$ -kV Contact Discharge, $\pm 15$ -kV HBM	3.3 or 5	Low pin count	16-pin SOIC, SSOP, TSSOP
	TRS3227	1	1	$\pm 8$ -kV Air-Gap Discharge, $\pm 8$ -kV Contact Discharge, $\pm 15$ -kV HBM	3.3 or 5	Auto-powerdown plus, ready signal	16-pin SSOP
	TRSF3221	1	1	$\pm 15$ -kV HBM	3.3 or 5	Auto-powerdown	16-pin SOIC, SSOP, TSSOP
	TRSF3222	2	2	$\pm 15$ -kV HBM	3.3 or 5	Enable, powerdown signal	20-pin SOIC, SSOP, TSSOP
	TRSF3223	2	2	$\pm 15$ -kV HBM	3.5 or 5	Auto-powerdown, enable signal	20-pin SOIC, SSOP, TSSOP
	TRSF3232	2	2	$\pm 15$ -kV HBM	3.3 or 5	Low pin count	16-pin SOIC, SSOP, TSSOP
	TRSF3238	5	3	$\pm 15$ -kV HBM	3.3 or 5	Auto-powerdown plus	28-pin SOIC, SSOP, TSSOP
	TRSF3243	3	5	$\pm 15$ -kV HBM	3.3 or 5	Auto-powerdown	28-pin SOIC, SSOP, TSSOP
–40°C to 85°C	TRSF3221E	1	1	$\pm 15$ -kV Air-Gap Discharge, $\pm 8$ -kV Contact Discharge, $\pm 15$ -kV HBM	3.3 or 5	Auto-powerdown	16-pin SOIC, SSOP, TSSOP
	TRSF3232E	2	2	$\pm 15$ -kV Air-Gap Discharge, $\pm 8$ -kV Contact Discharge, $\pm 15$ -kV HBM	3.3 or 5	Low pin count	16-pin SOIC, SSOP, TSSOP
	TRS3227	1	1	$\pm 8$ -kV Air-Gap Discharge, $\pm 8$ -kV Contact Discharge, $\pm 15$ -kV HBM	3.3 or 5	Auto-powerdown plus, ready signal	16-pin SSOP
	TRSF3221	1	1	$\pm 15$ -kV HBM	3.3 or 5	Auto-powerdown	16-pin SOIC, SSOP, TSSOP
	TRSF3222	2	2	$\pm 15$ -kV HBM	3.3 or 5	Enable, powerdown signal	20-pin SOIC, SSOP, TSSOP
	TRSF3223	2	2	$\pm 15$ -kV HBM	3.3 or 5	Auto-powerdown, enable signal	20-pin SOIC, SSOP, TSSOP
	TRSF3232	2	2	$\pm 15$ -kV HBM	3.3 or 5	Low pin count	16-pin SOIC, SSOP, TSSOP
	TRSF3238	5	3	$\pm 15$ -kV HBM	3.3 or 5	Auto-powerdown plus	28-pin SOIC, SSOP, TSSOP
	TRSF3243	3	5	$\pm 15$ -kV HBM	3.3 or 5	Auto-powerdown	28-pin SOIC, SSOP, TSSOP

**FUNCTION TABLES**

**Each Driver<sup>(1)</sup>**

INPUT DIN	OUTPUT DOUT
L	H
H	L

(1) H = high level, L = low level

**Each Receiver<sup>(1)</sup>**

INPUT RIN	OUTPUT ROUT
L	H
H	L
Open	H

(1) H = high level, L = low level,  
Open = input disconnected or  
connected driver off

**LOGIC DIAGRAM (POSITIVE LOGIC)**

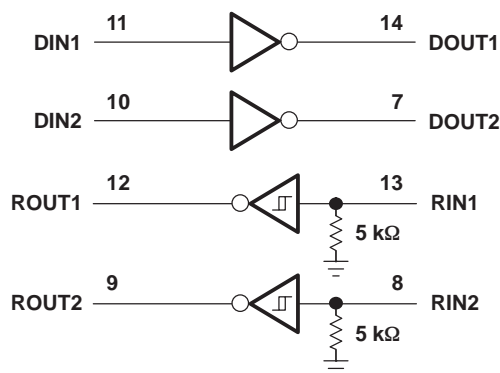

**TRSF3232E**  
**3-V TO 5.5-V TWO-CHANNEL RS-232 1-Mbit/s LINE DRIVER/RECEIVER**  
**WITH ±15-kV IEC ESD PROTECTION**

SLLS825–AUGUST 2007

**Absolute Maximum Ratings<sup>(1)</sup>**

over operating free-air temperature range (unless otherwise noted)

		MIN	MAX	UNIT	
V <sub>CC</sub>	Supply voltage range <sup>(2)</sup>	–0.3	6	V	
V+	Positive-output supply voltage range <sup>(2)</sup>	–0.3	7	V	
V–	Negative-output supply voltage range <sup>(2)</sup>	0.3	–7	V	
V+ – V–	Supply voltage difference <sup>(2)</sup>		13	V	
V <sub>I</sub>	Input voltage range	Drivers	–0.3	6	V
		Receivers	–25	25	
V <sub>O</sub>	Output voltage range	Drivers	–13.2	13.2	V
		Receivers	–0.3	V <sub>CC</sub> + 0.3	
θ <sub>JA</sub>	Package thermal impedance <sup>(3)(4)</sup>	D package		82	°C/W
		DB package		46	
		DW package		57	
		PW package		108	
T <sub>J</sub>	Operating virtual junction temperature		150	°C	
T <sub>stg</sub>	Storage temperature range	–65	150	°C	

- (1) Stresses beyond those listed under "absolute maximum ratings" may cause permanent damage to the device. These are stress ratings only, and functional operation of the device at these or any other conditions beyond those indicated under "recommended operating conditions" is not implied. Exposure to absolute-maximum-rated conditions for extended periods may affect device reliability.
- (2) All voltages are with respect to network GND.
- (3) Maximum power dissipation is a function of T<sub>J</sub>(max), θ<sub>JA</sub>, and T<sub>A</sub>. The maximum allowable power dissipation at any allowable ambient temperature is P<sub>D</sub> = (T<sub>J</sub>(max) – T<sub>A</sub>)/θ<sub>JA</sub>. Operating at the absolute maximum T<sub>J</sub> of 150°C can affect reliability.
- (4) The package thermal impedance is calculated in accordance with JESD 51-7.

**Recommended Operating Conditions<sup>(1)</sup>**

		MIN	NOM	MAX	UNIT	
Supply voltage		V <sub>CC</sub> = 3.3 V	3	3.3	3.6	V
		V <sub>CC</sub> = 5 V	4.5	5	5.5	
V <sub>IH</sub>	Driver high-level input voltage	DIN	V <sub>CC</sub> = 3.3 V	2		V
			V <sub>CC</sub> = 5 V	2.4		
V <sub>IL</sub>	Driver low-level input voltage	DIN		0.8	V	
V <sub>I</sub>	Driver input voltage	DIN	0	5.5	V	
	Receiver input voltage		–25	25		
T <sub>A</sub>	Operating free-air temperature	TRSF3232EI	–40	85	°C	
		TRSF3232EC	0	70		

- (1) Test conditions are C1–C4 = 0.1 μF at V<sub>CC</sub> = 3.3 V ± 0.3 V; C1 = 0.047 μF, C2–C4 = 0.33 μF at V<sub>CC</sub> = 5 V ± 0.5 V (see Figure 4).

**Electrical Characteristics<sup>(1)</sup>**

over recommended ranges of supply voltage and operating free-air temperature (unless otherwise noted)

PARAMETER	TEST CONDITIONS	MIN	TYP <sup>(2)</sup>	MAX	UNIT
I <sub>CC</sub>	Supply current	No load, V <sub>CC</sub> = 3.3 V or 5 V	0.3	1	mA

- (1) Test conditions are C1–C4 = 0.1 μF at V<sub>CC</sub> = 3.3 V ± 0.3 V; C1 = 0.047 μF, C2–C4 = 0.33 μF at V<sub>CC</sub> = 5 V ± 0.5 V (see Figure 4).
- (2) All typical values are at V<sub>CC</sub> = 3.3 V or V<sub>CC</sub> = 5 V, and T<sub>A</sub> = 25°C.

## DRIVER SECTION

### Electrical Characteristics<sup>(1)</sup>

over recommended ranges of supply voltage and operating free-air temperature (unless otherwise noted)

PARAMETER	TEST CONDITIONS	MIN	TYP <sup>(2)</sup>	MAX	UNIT
V <sub>OH</sub> High-level output voltage	DOUT at R <sub>L</sub> = 3 k $\Omega$ to GND, DIN = GND	5	5.5		V
V <sub>OL</sub> Low-level output voltage	DOUT at R <sub>L</sub> = 3 k $\Omega$ to GND, DIN = V <sub>CC</sub>	–5	–5.4		V
I <sub>IH</sub> High-level input current	V <sub>I</sub> = V <sub>CC</sub>		$\pm 0.01$	$\pm 1$	$\mu$ A
I <sub>IL</sub> Low-level input current	V <sub>I</sub> at GND		$\pm 0.01$	$\pm 1$	$\mu$ A
I <sub>OS</sub> <sup>(3)</sup> Short-circuit output current	V <sub>CC</sub> = 3.6 V, V <sub>O</sub> = 0 V		$\pm 35$	$\pm 60$	mA
	V <sub>CC</sub> = 5.5 V, V <sub>O</sub> = 0 V		$\pm 35$	$\pm 90$	
r <sub>o</sub> Output resistance	V <sub>CC</sub> , V <sub>+</sub> , and V <sub>–</sub> = 0 V, V <sub>O</sub> = $\pm 2$ V	300	10M		$\Omega$

(1) Test conditions are C1–C4 = 0.1  $\mu$ F at V<sub>CC</sub> = 3.3 V  $\pm$  0.3 V; C1 = 0.047  $\mu$ F, C2–C4 = 0.33  $\mu$ F at V<sub>CC</sub> = 5 V  $\pm$  0.5 V (see Figure 4).

(2) All typical values are at V<sub>CC</sub> = 3.3 V or V<sub>CC</sub> = 5 V, and T<sub>A</sub> = 25°C.

(3) Short-circuit durations should be controlled to prevent exceeding the device absolute power dissipation ratings, and not more than one output should be shorted at a time.

### Switching Characteristics<sup>(1)</sup>

over recommended ranges of supply voltage and operating free-air temperature (unless otherwise noted)

PARAMETER	TEST CONDITIONS	MIN	TYP <sup>(2)</sup>	MAX	UNIT
Maximum data rate (see Figure 1)	R <sub>L</sub> = 3 k $\Omega$ , One DOUT switching	C <sub>L</sub> = 250 pF, V <sub>CC</sub> = 3 V to 4.5 V	1000		kbit/s
		C <sub>L</sub> = 1000 pF, V <sub>CC</sub> = 3.5 V to 5.5 V	1000		
t <sub>sk(p)</sub> Pulse skew <sup>(3)</sup>	C <sub>L</sub> = 150 pF to 2500 pF, R <sub>L</sub> = 3 k $\Omega$ to 7 k $\Omega$ , See Figure 2		300		ns
SR(tr) Slew rate, transition region (see Figure 1)	R <sub>L</sub> = 3 k $\Omega$ to 7 k $\Omega$ , C <sub>L</sub> = 150 pF to 1000 pF, V <sub>CC</sub> = 3.3 V		14	150	V/ $\mu$ s

(1) Test conditions are C1–C4 = 0.1  $\mu$ F at V<sub>CC</sub> = 3.3 V  $\pm$  0.3 V; C1 = 0.047  $\mu$ F, C2–C4 = 0.33  $\mu$ F at V<sub>CC</sub> = 5 V  $\pm$  0.5 V (see Figure 4).

(2) All typical values are at V<sub>CC</sub> = 3.3 V or V<sub>CC</sub> = 5 V, and T<sub>A</sub> = 25°C.

(3) Pulse skew is defined as |t<sub>PLH</sub> – t<sub>PHL</sub>| of each channel of the same device.

## ESD Protection

TERMINAL		TEST CONDITIONS	TYP	UNIT
NAME	NO.			
DOUT	7, 14	HBM	$\pm 15$	kV
		IEC 61000-4-2 Air-Gap Discharge	$\pm 15$	
		IEC 61000-4-2 Contact Discharge	$\pm 8$	

**TRSF3232E**  
**3-V TO 5.5-V TWO-CHANNEL RS-232 1-Mbit/s LINE DRIVER/RECEIVER**  
**WITH ±15-kV IEC ESD PROTECTION**

SLLS825 – AUGUST 2007

**RECEIVER SECTION**

**Electrical Characteristics<sup>(1)</sup>**

over recommended ranges of supply voltage and operating free-air temperature (unless otherwise noted)

PARAMETER		TEST CONDITIONS	MIN	TYP <sup>(2)</sup>	MAX	UNIT
V <sub>OH</sub>	High-level output voltage	I <sub>OH</sub> = -1 mA	V <sub>CC</sub> - 0.6	V <sub>CC</sub> - 0.1		V
V <sub>OL</sub>	Low-level output voltage	I <sub>OL</sub> = 1.6 mA			0.4	V
V <sub>IT+</sub>	Positive-going input threshold voltage	V <sub>CC</sub> = 3.3 V		1.5	2.4	V
		V <sub>CC</sub> = 5 V		1.8	2.4	
V <sub>IT-</sub>	Negative-going input threshold voltage	V <sub>CC</sub> = 3.3 V	0.6	1.2		V
		V <sub>CC</sub> = 5 V	0.8	1.5		
V <sub>hys</sub>	Input hysteresis (V <sub>IT+</sub> - V <sub>IT-</sub> )			0.3		V
r <sub>i</sub>	Input resistance	V <sub>i</sub> = ±3 V to ±25 V	3	5	7	kΩ

(1) Test conditions are C1–C4 = 0.1 μF at V<sub>CC</sub> = 3.3 V ± 0.3 V; C1 = 0.047 μF, C2–C4 = 0.33 μF at V<sub>CC</sub> = 5 V ± 0.5 V (see Figure 4).

(2) All typical values are at V<sub>CC</sub> = 3.3 V or V<sub>CC</sub> = 5 V, and T<sub>A</sub> = 25°C.

**Switching Characteristics<sup>(1)</sup>**

over recommended ranges of supply voltage and operating free-air temperature (unless otherwise noted)

PARAMETER		TEST CONDITIONS	TYP <sup>(2)</sup>	UNIT
t <sub>PLH</sub>	Propagation delay time, low- to high-level output	C <sub>L</sub> = 150 pF	300	ns
t <sub>PHL</sub>	Propagation delay time, high- to low-level output	C <sub>L</sub> = 150 pF	300	ns
t <sub>sk(p)</sub>	Pulse skew <sup>(3)</sup>		300	ns

(1) Test conditions are C1–C4 = 0.1 μF at V<sub>CC</sub> = 3.3 V ± 0.3 V; C1 = 0.047 μF, C2–C4 = 0.33 μF at V<sub>CC</sub> = 5 V ± 0.5 V (see Figure 4).

(2) All typical values are at V<sub>CC</sub> = 3.3 V or V<sub>CC</sub> = 5 V, and T<sub>A</sub> = 25°C.

(3) Pulse skew is defined as |t<sub>PLH</sub> - t<sub>PHL</sub>| of each channel of the same device.

**ESD Protection**

TERMINAL		TEST CONDITIONS	TYP	UNIT
NAME	NO.			
RIN	8, 13	HBM	±15	kV
		IEC 61000-4-2 Air-Gap Discharge	±15	
		IEC 61000-4-2 Contact Discharge	±8	

PARAMETER MEASUREMENT INFORMATION

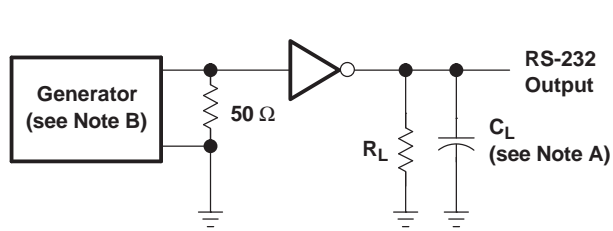

TEST CIRCUIT

$$SR(tr) = \frac{6\text{ V}}{t_{THL} \text{ or } t_{TLH}}$$

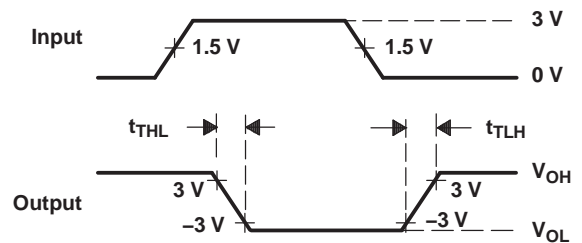

VOLTAGE WAVEFORMS

NOTES: A.  $C_L$  includes probe and jig capacitance.

B. The pulse generator has the following characteristics: PRR = 250 kbit/s,  $Z_O = 50\ \Omega$ , 50% duty cycle,  $t_r \leq 10\text{ ns}$ ,  $t_f \leq 10\text{ ns}$ .

Figure 1. Driver Slew Rate

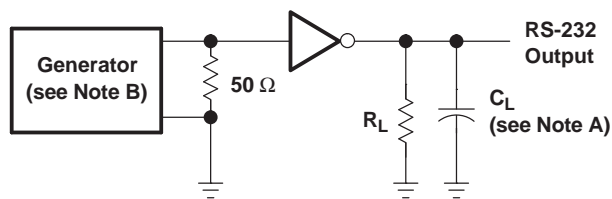

TEST CIRCUIT

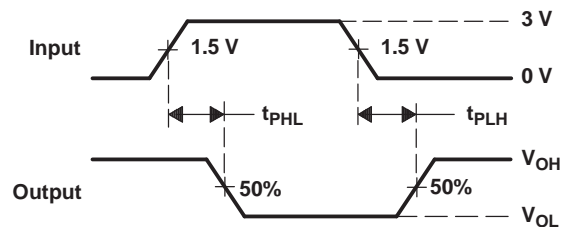

VOLTAGE WAVEFORMS

NOTES: A.  $C_L$  includes probe and jig capacitance.

B. The pulse generator has the following characteristics: PRR = 250 kbit/s,  $Z_O = 50\ \Omega$ , 50% duty cycle,  $t_r \leq 10\text{ ns}$ ,  $t_f \leq 10\text{ ns}$ .

Figure 2. Driver Pulse Skew

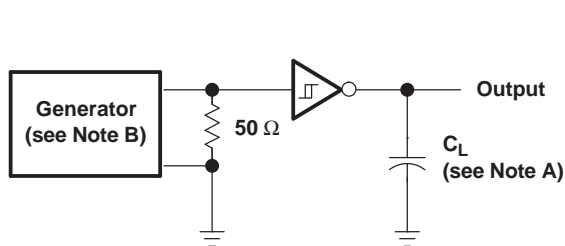

TEST CIRCUIT

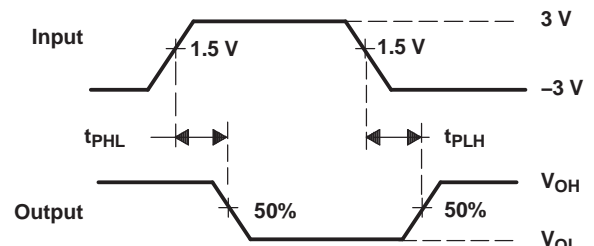

VOLTAGE WAVEFORMS

NOTES: A.  $C_L$  includes probe and jig capacitance.

B. The pulse generator has the following characteristics:  $Z_O = 50\ \Omega$ , 50% duty cycle,  $t_r \leq 10\text{ ns}$ ,  $t_f \leq 10\text{ ns}$ .

Figure 3. Receiver Propagation Delay Times

**APPLICATION INFORMATION**

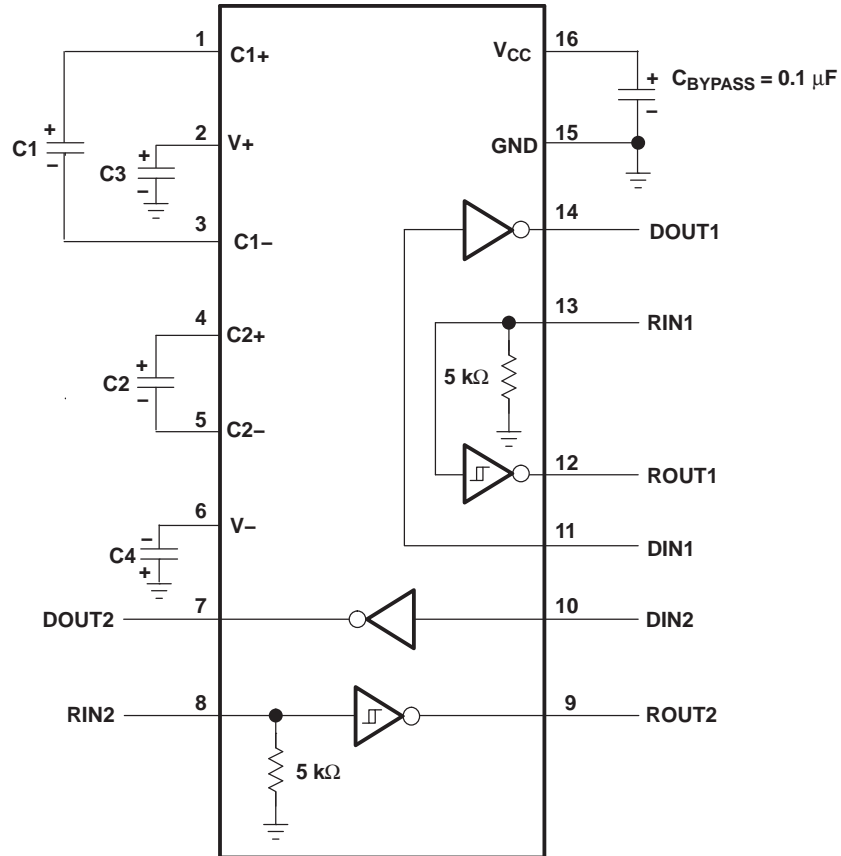

**V<sub>CC</sub> vs CAPACITOR VALUES**

V <sub>CC</sub>	C1	C2, C3, C4
3.3 V $\pm$ 0.3 V	0.1 $\mu$ F	0.1 $\mu$ F
5 V $\pm$ 0.5 V	0.047 $\mu$ F	0.33 $\mu$ F
3 V to 5.5 V	0.1 $\mu$ F	0.47 $\mu$ F

A. C3 can be connected to V<sub>CC</sub> or GND.

**Figure 4. Typical Operating Circuit and Capacitor Values**

**PACKAGING INFORMATION**

Orderable Device	Status (1)	Package Type	Package Drawing	Pins	Package Qty	Eco Plan (2)	Lead/Ball Finish (6)	MSL Peak Temp (3)	Op Temp (°C)	Device Marking (4/5)	Samples
TRSF3232ECD	ACTIVE	SOIC	D	16	40	Green (RoHS & no Sb/Br)	CU NIPDAU	Level-1-260C-UNLIM	0 to 70	TRSF3232EC	<a href="#">Samples</a>
TRSF3232ECDB	ACTIVE	SSOP	DB	16	80	Green (RoHS & no Sb/Br)	CU NIPDAU	Level-1-260C-UNLIM	0 to 70	RT32EC	<a href="#">Samples</a>
TRSF3232ECDBR	ACTIVE	SSOP	DB	16	2000	Green (RoHS & no Sb/Br)	CU NIPDAU	Level-1-260C-UNLIM	0 to 70	RT32EC	<a href="#">Samples</a>
TRSF3232ECDBRG4	ACTIVE	SSOP	DB	16	2000	Green (RoHS & no Sb/Br)	CU NIPDAU	Level-1-260C-UNLIM	0 to 70	RT32EC	<a href="#">Samples</a>
TRSF3232ECDR	ACTIVE	SOIC	D	16	2500	Green (RoHS & no Sb/Br)	CU NIPDAU	Level-1-260C-UNLIM	0 to 70	TRSF3232EC	<a href="#">Samples</a>
TRSF3232ECDWR	ACTIVE	SOIC	DW	16	2000	Green (RoHS & no Sb/Br)	CU NIPDAU	Level-1-260C-UNLIM	0 to 70	TRSF3232EC	<a href="#">Samples</a>
TRSF3232ECPWR	ACTIVE	TSSOP	PW	16	2000	Green (RoHS & no Sb/Br)	CU NIPDAU	Level-1-260C-UNLIM	0 to 70	RT32EC	<a href="#">Samples</a>
TRSF3232EID	ACTIVE	SOIC	D	16	40	Green (RoHS & no Sb/Br)	CU NIPDAU	Level-1-260C-UNLIM	-40 to 85	TRSF3232EI	<a href="#">Samples</a>
TRSF3232EIDBR	ACTIVE	SSOP	DB	16	2000	Green (RoHS & no Sb/Br)	CU NIPDAU	Level-1-260C-UNLIM	-40 to 85	RT32EI	<a href="#">Samples</a>
TRSF3232EIDG4	ACTIVE	SOIC	D	16	40	Green (RoHS & no Sb/Br)	CU NIPDAU	Level-1-260C-UNLIM	-40 to 85	TRSF3232EI	<a href="#">Samples</a>
TRSF3232EIDR	ACTIVE	SOIC	D	16	2500	Green (RoHS & no Sb/Br)	CU NIPDAU	Level-1-260C-UNLIM	-40 to 85	TRSF3232EI	<a href="#">Samples</a>
TRSF3232EIDW	ACTIVE	SOIC	DW	16	40	Green (RoHS & no Sb/Br)	CU NIPDAU	Level-1-260C-UNLIM	-40 to 85	TRSF3232EI	<a href="#">Samples</a>
TRSF3232EIDWG4	ACTIVE	SOIC	DW	16	40	Green (RoHS & no Sb/Br)	CU NIPDAU	Level-1-260C-UNLIM	-40 to 85	TRSF3232EI	<a href="#">Samples</a>
TRSF3232EIDWR	ACTIVE	SOIC	DW	16	2000	Green (RoHS & no Sb/Br)	CU NIPDAU	Level-1-260C-UNLIM	-40 to 85	TRSF3232EI	<a href="#">Samples</a>
TRSF3232EIPW	ACTIVE	TSSOP	PW	16	90	Green (RoHS & no Sb/Br)	CU NIPDAU	Level-1-260C-UNLIM	-40 to 85	RT32EI	<a href="#">Samples</a>
TRSF3232EIPWG4	ACTIVE	TSSOP	PW	16	90	Green (RoHS & no Sb/Br)	CU NIPDAU	Level-1-260C-UNLIM	-40 to 85	RT32EI	<a href="#">Samples</a>
TRSF3232EIPWR	ACTIVE	TSSOP	PW	16	2000	Green (RoHS & no Sb/Br)	CU NIPDAU	Level-1-260C-UNLIM	-40 to 85	RT32EI	<a href="#">Samples</a>

Orderable Device	Status (1)	Package Type	Package Drawing	Pins	Package Qty	Eco Plan (2)	Lead/Ball Finish (6)	MSL Peak Temp (3)	Op Temp (°C)	Device Marking (4/5)	Samples
TRSF3232EIPWRG4	ACTIVE	TSSOP	PW	16	2000	Green (RoHS & no Sb/Br)	CU NIPDAU	Level-1-260C-UNLIM	-40 to 85	RT32EI	<b>Samples</b>

(1) The marketing status values are defined as follows:

**ACTIVE:** Product device recommended for new designs.

**LIFEBUY:** TI has announced that the device will be discontinued, and a lifetime-buy period is in effect.

**NRND:** Not recommended for new designs. Device is in production to support existing customers, but TI does not recommend using this part in a new design.

**PREVIEW:** Device has been announced but is not in production. Samples may or may not be available.

**OBSOLETE:** TI has discontinued the production of the device.

(2) Eco Plan - The planned eco-friendly classification: Pb-Free (RoHS), Pb-Free (RoHS Exempt), or Green (RoHS & no Sb/Br) - please check <http://www.ti.com/productcontent> for the latest availability information and additional product content details.

**TBD:** The Pb-Free/Green conversion plan has not been defined.

**Pb-Free (RoHS):** TI's terms "Lead-Free" or "Pb-Free" mean semiconductor products that are compatible with the current RoHS requirements for all 6 substances, including the requirement that lead not exceed 0.1% by weight in homogeneous materials. Where designed to be soldered at high temperatures, TI Pb-Free products are suitable for use in specified lead-free processes.

**Pb-Free (RoHS Exempt):** This component has a RoHS exemption for either 1) lead-based flip-chip solder bumps used between the die and package, or 2) lead-based die adhesive used between the die and leadframe. The component is otherwise considered Pb-Free (RoHS compatible) as defined above.

**Green (RoHS & no Sb/Br):** TI defines "Green" to mean Pb-Free (RoHS compatible), and free of Bromine (Br) and Antimony (Sb) based flame retardants (Br or Sb do not exceed 0.1% by weight in homogeneous material)

(3) MSL, Peak Temp. - The Moisture Sensitivity Level rating according to the JEDEC industry standard classifications, and peak solder temperature.

(4) There may be additional marking, which relates to the logo, the lot trace code information, or the environmental category on the device.

(5) Multiple Device Markings will be inside parentheses. Only one Device Marking contained in parentheses and separated by a "~" will appear on a device. If a line is indented then it is a continuation of the previous line and the two combined represent the entire Device Marking for that device.

(6) Lead/Ball Finish - Orderable Devices may have multiple material finish options. Finish options are separated by a vertical ruled line. Lead/Ball Finish values may wrap to two lines if the finish value exceeds the maximum column width.

**Important Information and Disclaimer:** The information provided on this page represents TI's knowledge and belief as of the date that it is provided. TI bases its knowledge and belief on information provided by third parties, and makes no representation or warranty as to the accuracy of such information. Efforts are underway to better integrate information from third parties. TI has taken and continues to take reasonable steps to provide representative and accurate information but may not have conducted destructive testing or chemical analysis on incoming materials and chemicals. TI and TI suppliers consider certain information to be proprietary, and thus CAS numbers and other limited information may not be available for release.

In no event shall TI's liability arising out of such information exceed the total purchase price of the TI part(s) at issue in this document sold by TI to Customer on an annual basis.

**TAPE AND REEL INFORMATION**
**REEL DIMENSIONS**

**TAPE DIMENSIONS**

A0	Dimension designed to accommodate the component width
B0	Dimension designed to accommodate the component length
K0	Dimension designed to accommodate the component thickness
W	Overall width of the carrier tape
P1	Pitch between successive cavity centers

**TAPE AND REEL INFORMATION**

\*All dimensions are nominal

Device	Package Type	Package Drawing	Pins	SPQ	Reel Diameter (mm)	Reel Width W1 (mm)	A0 (mm)	B0 (mm)	K0 (mm)	P1 (mm)	W (mm)	Pin1 Quadrant
TRSF3232ECDBR	SSOP	DB	16	2000	330.0	16.4	8.2	6.6	2.5	12.0	16.0	Q1
TRSF3232ECDR	SOIC	D	16	2500	330.0	16.4	6.5	10.3	2.1	8.0	16.0	Q1
TRSF3232ECDWR	SOIC	DW	16	2000	330.0	16.4	10.75	10.7	2.7	12.0	16.0	Q1
TRSF3232ECPWR	TSSOP	PW	16	2000	330.0	12.4	6.9	5.6	1.6	8.0	12.0	Q1
TRSF3232EIDBR	SSOP	DB	16	2000	330.0	16.4	8.2	6.6	2.5	12.0	16.0	Q1
TRSF3232EIDR	SOIC	D	16	2500	330.0	16.4	6.5	10.3	2.1	8.0	16.0	Q1
TRSF3232EIDWR	SOIC	DW	16	2000	330.0	16.4	10.75	10.7	2.7	12.0	16.0	Q1
TRSF3232EIPWR	TSSOP	PW	16	2000	330.0	12.4	6.9	5.6	1.6	8.0	12.0	Q1

**TAPE AND REEL BOX DIMENSIONS**

\*All dimensions are nominal

Device	Package Type	Package Drawing	Pins	SPQ	Length (mm)	Width (mm)	Height (mm)
TRSF3232ECDBR	SSOP	DB	16	2000	367.0	367.0	38.0
TRSF3232ECDR	SOIC	D	16	2500	367.0	367.0	38.0
TRSF3232ECDWR	SOIC	DW	16	2000	367.0	367.0	38.0
TRSF3232ECPWR	TSSOP	PW	16	2000	367.0	367.0	35.0
TRSF3232EIDBR	SSOP	DB	16	2000	367.0	367.0	38.0
TRSF3232EIDR	SOIC	D	16	2500	367.0	367.0	38.0
TRSF3232EIDWR	SOIC	DW	16	2000	367.0	367.0	38.0
TRSF3232EIPWR	TSSOP	PW	16	2000	367.0	367.0	35.0

PW (R-PDSO-G16)

PLASTIC SMALL OUTLINE

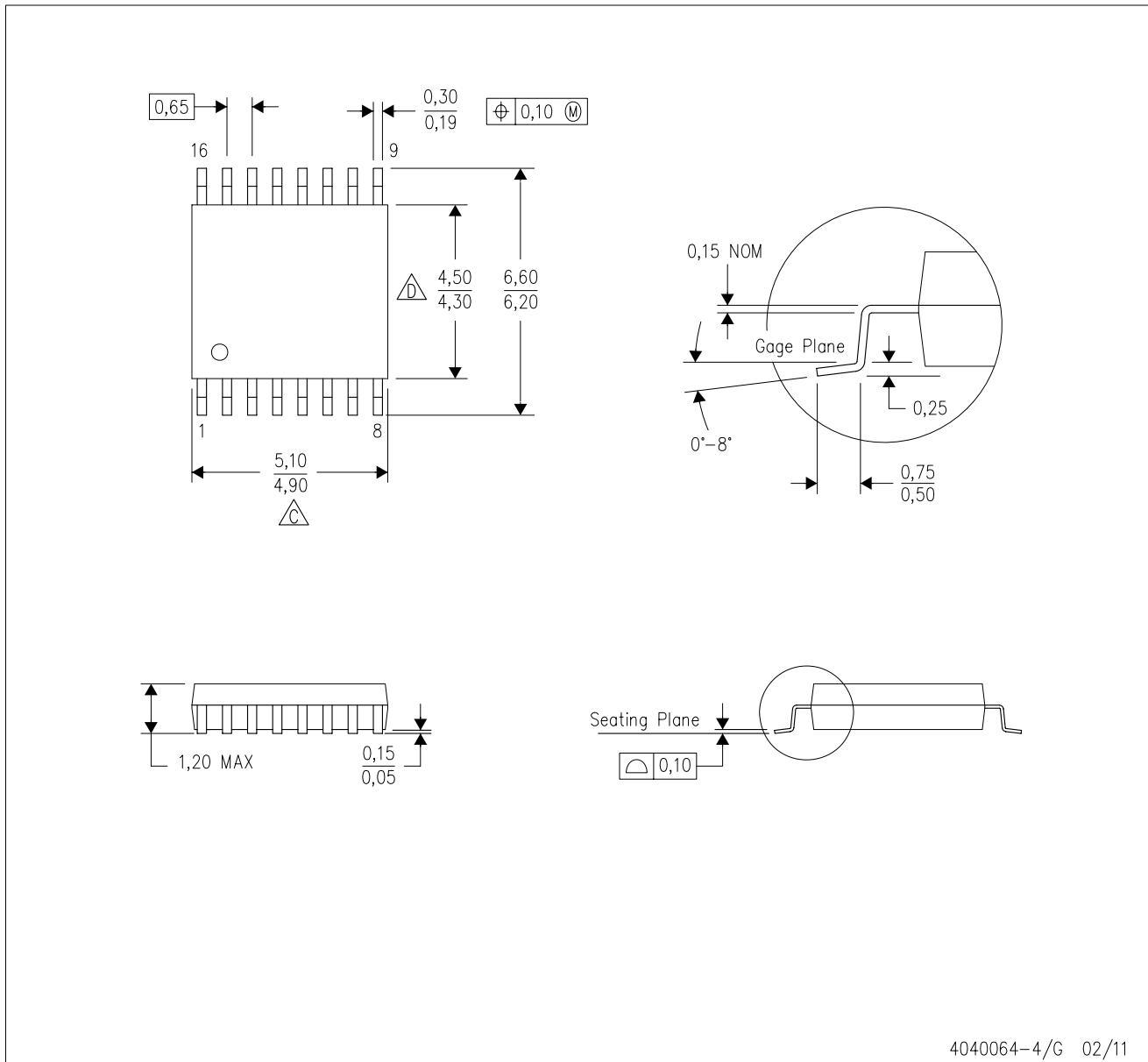

4040064-4/G 02/11

- NOTES:
- A. All linear dimensions are in millimeters. Dimensioning and tolerancing per ASME Y14.5M-1994.
  - B. This drawing is subject to change without notice.
  -  Body length does not include mold flash, protrusions, or gate burrs. Mold flash, protrusions, or gate burrs shall not exceed 0,15 each side.
  -  Body width does not include interlead flash. Interlead flash shall not exceed 0,25 each side.
  - E. Falls within JEDEC MO-153

PW (R-PDSO-G16)

PLASTIC SMALL OUTLINE

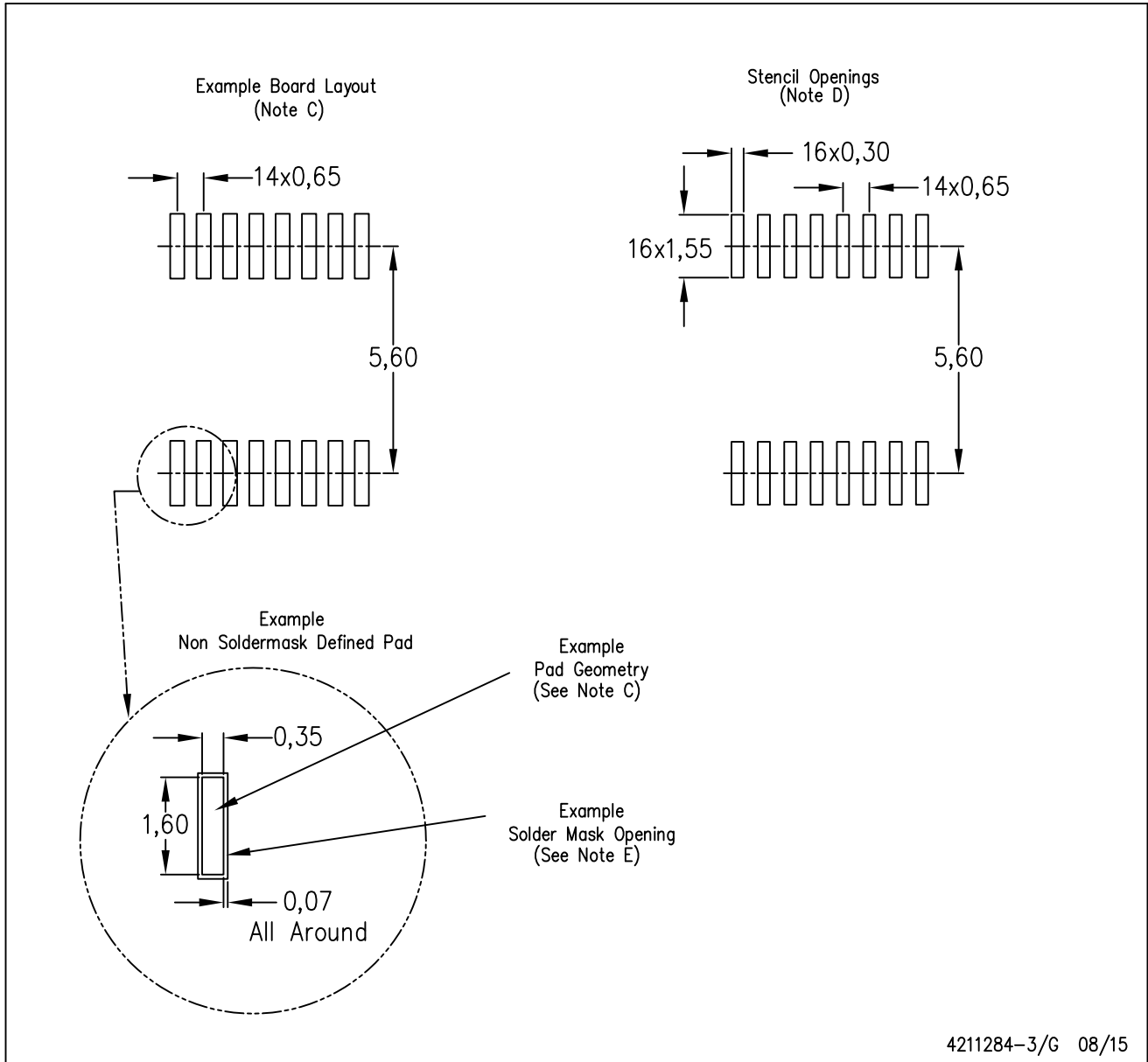

- NOTES:
- All linear dimensions are in millimeters.
  - This drawing is subject to change without notice.
  - Publication IPC-7351 is recommended for alternate designs.
  - Laser cutting apertures with trapezoidal walls and also rounding corners will offer better paste release. Customers should contact their board assembly site for stencil design recommendations. Refer to IPC-7525 for other stencil recommendations.
  - Customers should contact their board fabrication site for solder mask tolerances between and around signal pads.



D (R-PDSO-G16)

PLASTIC SMALL OUTLINE



- NOTES:
- A. All linear dimensions are in inches (millimeters).
  - B. This drawing is subject to change without notice.
  - C. Body length does not include mold flash, protrusions, or gate burrs. Mold flash, protrusions, or gate burrs shall not exceed 0.006 (0,15) each side.
  - D. Body width does not include interlead flash. Interlead flash shall not exceed 0.017 (0,43) each side.
  - E. Reference JEDEC MS-012 variation AC.

D (R-PDSO-G16)

PLASTIC SMALL OUTLINE



- NOTES:
- All linear dimensions are in millimeters.
  - This drawing is subject to change without notice.
  - Publication IPC-7351 is recommended for alternate designs.
  - Laser cutting apertures with trapezoidal walls and also rounding corners will offer better paste release. Customers should contact their board assembly site for stencil design recommendations. Refer to IPC-7525 for other stencil recommendations.
  - Customers should contact their board fabrication site for solder mask tolerances between and around signal pads.

DW (R-PDSO-G16)

PLASTIC SMALL OUTLINE



- NOTES:
- A. All linear dimensions are in inches (millimeters). Dimensioning and tolerancing per ASME Y14.5M-1994.
  - B. This drawing is subject to change without notice.
  - C. Body dimensions do not include mold flash or protrusion not to exceed 0.006 (0,15).
  - D. Falls within JEDEC MS-013 variation AA.

## IMPORTANT NOTICE

Texas Instruments Incorporated (TI) reserves the right to make corrections, enhancements, improvements and other changes to its semiconductor products and services per JESD46, latest issue, and to discontinue any product or service per JESD48, latest issue. Buyers should obtain the latest relevant information before placing orders and should verify that such information is current and complete.

TI's published terms of sale for semiconductor products (<http://www.ti.com/sc/docs/stdterms.htm>) apply to the sale of packaged integrated circuit products that TI has qualified and released to market. Additional terms may apply to the use or sale of other types of TI products and services.

Reproduction of significant portions of TI information in TI data sheets is permissible only if reproduction is without alteration and is accompanied by all associated warranties, conditions, limitations, and notices. TI is not responsible or liable for such reproduced documentation. Information of third parties may be subject to additional restrictions. Resale of TI products or services with statements different from or beyond the parameters stated by TI for that product or service voids all express and any implied warranties for the associated TI product or service and is an unfair and deceptive business practice. TI is not responsible or liable for any such statements.

Buyers and others who are developing systems that incorporate TI products (collectively, "Designers") understand and agree that Designers remain responsible for using their independent analysis, evaluation and judgment in designing their applications and that Designers have full and exclusive responsibility to assure the safety of Designers' applications and compliance of their applications (and of all TI products used in or for Designers' applications) with all applicable regulations, laws and other applicable requirements. Designer represents that, with respect to their applications, Designer has all the necessary expertise to create and implement safeguards that (1) anticipate dangerous consequences of failures, (2) monitor failures and their consequences, and (3) lessen the likelihood of failures that might cause harm and take appropriate actions. Designer agrees that prior to using or distributing any applications that include TI products, Designer will thoroughly test such applications and the functionality of such TI products as used in such applications.

TI's provision of technical, application or other design advice, quality characterization, reliability data or other services or information, including, but not limited to, reference designs and materials relating to evaluation modules, (collectively, "TI Resources") are intended to assist designers who are developing applications that incorporate TI products; by downloading, accessing or using TI Resources in any way, Designer (individually or, if Designer is acting on behalf of a company, Designer's company) agrees to use any particular TI Resource solely for this purpose and subject to the terms of this Notice.

TI's provision of TI Resources does not expand or otherwise alter TI's applicable published warranties or warranty disclaimers for TI products, and no additional obligations or liabilities arise from TI providing such TI Resources. TI reserves the right to make corrections, enhancements, improvements and other changes to its TI Resources. TI has not conducted any testing other than that specifically described in the published documentation for a particular TI Resource.

Designer is authorized to use, copy and modify any individual TI Resource only in connection with the development of applications that include the TI product(s) identified in such TI Resource. NO OTHER LICENSE, EXPRESS OR IMPLIED, BY ESTOPPEL OR OTHERWISE TO ANY OTHER TI INTELLECTUAL PROPERTY RIGHT, AND NO LICENSE TO ANY TECHNOLOGY OR INTELLECTUAL PROPERTY RIGHT OF TI OR ANY THIRD PARTY IS GRANTED HEREIN, including but not limited to any patent right, copyright, mask work right, or other intellectual property right relating to any combination, machine, or process in which TI products or services are used. Information regarding or referencing third-party products or services does not constitute a license to use such products or services, or a warranty or endorsement thereof. Use of TI Resources may require a license from a third party under the patents or other intellectual property of the third party, or a license from TI under the patents or other intellectual property of TI.

TI RESOURCES ARE PROVIDED "AS IS" AND WITH ALL FAULTS. TI DISCLAIMS ALL OTHER WARRANTIES OR REPRESENTATIONS, EXPRESS OR IMPLIED, REGARDING RESOURCES OR USE THEREOF, INCLUDING BUT NOT LIMITED TO ACCURACY OR COMPLETENESS, TITLE, ANY EPIDEMIC FAILURE WARRANTY AND ANY IMPLIED WARRANTIES OF MERCHANTABILITY, FITNESS FOR A PARTICULAR PURPOSE, AND NON-INFRINGEMENT OF ANY THIRD PARTY INTELLECTUAL PROPERTY RIGHTS. TI SHALL NOT BE LIABLE FOR AND SHALL NOT DEFEND OR INDEMNIFY DESIGNER AGAINST ANY CLAIM, INCLUDING BUT NOT LIMITED TO ANY INFRINGEMENT CLAIM THAT RELATES TO OR IS BASED ON ANY COMBINATION OF PRODUCTS EVEN IF DESCRIBED IN TI RESOURCES OR OTHERWISE. IN NO EVENT SHALL TI BE LIABLE FOR ANY ACTUAL, DIRECT, SPECIAL, COLLATERAL, INDIRECT, PUNITIVE, INCIDENTAL, CONSEQUENTIAL OR EXEMPLARY DAMAGES IN CONNECTION WITH OR ARISING OUT OF TI RESOURCES OR USE THEREOF, AND REGARDLESS OF WHETHER TI HAS BEEN ADVISED OF THE POSSIBILITY OF SUCH DAMAGES.

Unless TI has explicitly designated an individual product as meeting the requirements of a particular industry standard (e.g., ISO/TS 16949 and ISO 26262), TI is not responsible for any failure to meet such industry standard requirements.

Where TI specifically promotes products as facilitating functional safety or as compliant with industry functional safety standards, such products are intended to help enable customers to design and create their own applications that meet applicable functional safety standards and requirements. Using products in an application does not by itself establish any safety features in the application. Designers must ensure compliance with safety-related requirements and standards applicable to their applications. Designer may not use any TI products in life-critical medical equipment unless authorized officers of the parties have executed a special contract specifically governing such use. Life-critical medical equipment is medical equipment where failure of such equipment would cause serious bodily injury or death (e.g., life support, pacemakers, defibrillators, heart pumps, neurostimulators, and implantables). Such equipment includes, without limitation, all medical devices identified by the U.S. Food and Drug Administration as Class III devices and equivalent classifications outside the U.S.

TI may expressly designate certain products as completing a particular qualification (e.g., Q100, Military Grade, or Enhanced Product). Designers agree that it has the necessary expertise to select the product with the appropriate qualification designation for their applications and that proper product selection is at Designers' own risk. Designers are solely responsible for compliance with all legal and regulatory requirements in connection with such selection.

Designer will fully indemnify TI and its representatives against any damages, costs, losses, and/or liabilities arising out of Designer's non-compliance with the terms and provisions of this Notice.