

ADC14X250 14-Bit 250 MSPS Single Channel ADC With 5 Gb/s JESD204B Output

1 Features

- Resolution: 14-Bit
- Conversion Rate: 250 MSPS
- Performance:
 - Input: 240 MHz, –3 dBFS
 - SNR: 70.1 dBFS
 - Noise Spectral Density: –151.1 dBFS/Hz
 - SFDR: 87 dBFS
 - Non-HD2 and Non-HD3 SPUR: –92 dBFS
 - No Input SNR: 71.1 dBFS
- Power Dissipation: 584 mW
- Performance Rated up to 105°C (at thermal pad)
- JESD204B Subclass 1 Single Lane Serial Data Interface With Lane Rate Up To 5 Gb/s
- Buffered Analog Inputs
- Differential Input Phase and Amplitude Correction
- Input Sampling Clock Divider (Divide-by-1,2,4,8)
- 4-Wire Serial Peripheral Interface (SPI)
- 32-Pin WQFN Package (5x5 mm, 0.5-mm Pitch)

2 Applications

- High IF Sampling Receivers
- Multi-Carrier Base Station Receivers
 - GSM/EDGE, CDMA2000, UMTS, LTE, WiMax
- Diversity, Multi-Mode, and Multiband Receivers
- Digital Pre-Distortion
- Software Defined Radio (SDR)
- Test and Measurement Equipment
- Communications Instrumentation
- Radar
- Portable Instrumentation

3 Description

The ADC14X250 device is a monolithic single-channel high performance analog-to-digital converter capable of converting analog input signals into 14-bit digital words with a sampling rate of 250 MSPS. This converter uses a differential pipelined architecture with integrated input buffer to provide excellent dynamic performance and low power consumption across an extended temperature range from –40°C to 105°C as measured at the device's PCB footprint thermal pad.

The integrated input buffer eliminates charge kickback noise coming from the internal switched capacitor sampling circuits and eases the system-level design of the driving amplifier, anti-aliasing filter, and impedance matching. The buffer can be also be adjusted to correct for phase and amplitude imbalance of the differential input signal path to improve even order harmonic distortion. An input sampling clock divider provides integer divide ratios to simplify system clocking. An integrated low-noise voltage reference eases board level design without requiring external decoupling capacitors. The output digital data is provided through a JESD204B subclass 1 single lane interface from a 32-pin, 5-mm × 5-mm WQFN package. The ADC14X250 operates on 1.2 V, 1.8 V and 3.0 V power supplies. A SPI is available to configure the device that is compatible with 1.2-V to 3-V logic.

Device Information⁽¹⁾

PART NAME	PACKAGE	BODY SIZE (NOM)
ADC14X250	WQFN (32)	5.00 × 5.00 mm

(1) For all available packages, see the orderable addendum at the end of the data sheet.

1-Tone Spectrum, Input 240 MHz –3 dBFS

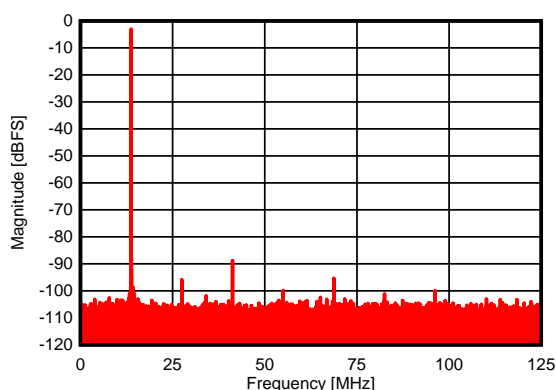

Performance Stability Across Temperature (240 MHz)

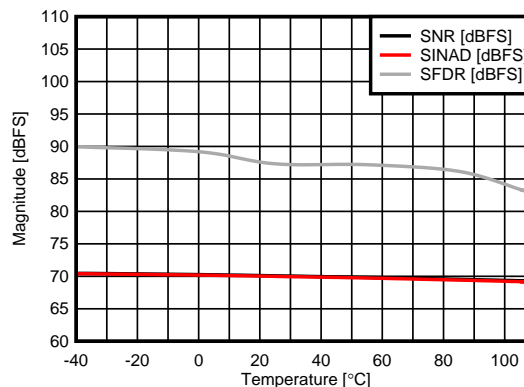

Table of Contents

1	Features	1	8	Detailed Description	23
2	Applications	1	8.1	Overview	23
3	Description	1	8.2	Functional Block Diagram	23
4	Revision History	2	8.3	Feature Description	23
5	Pin Configuration and Functions	3	8.4	Device Functional Modes	32
6	Specifications	6	8.5	Register Map	33
6.1	Absolute Maximum Ratings	6	9	Application and Implementation	40
6.2	ESD Ratings	6	9.1	Application Information	40
6.3	Recommended Operating Conditions	6	9.2	Typical Applications	54
6.4	Thermal Information	7	10	Power Supply Recommendations	59
6.5	Electrical Characteristics: Static Converter Performance	7	10.1	Power Supply Design	59
6.6	Electrical Characteristics: Dynamic Converter Performance	7	10.2	Decoupling	59
6.7	Electrical Characteristics: Power Supply	10	11	Layout	60
6.8	Electrical Characteristics: Analog Interface	10	11.1	Layout Guidelines	60
6.9	Digital Input Characteristics	11	12	Device and Documentation Support	62
6.10	Electrical Characteristics: Serial Data Output Interface	12	12.1	Device Support	62
6.11	Electrical Characteristics: Digital Input	12	12.2	Receiving Notification of Documentation Updates	64
6.12	Timing Requirements	13	12.3	Community Resources	64
6.13	Typical Characteristics	17	12.4	Trademarks	64
7	Parameter Measurement Information	22	12.5	Electrostatic Discharge Caution	64
7.1	JESD204B Interface Functional Characteristics	22	12.6	Glossary	64
			13	Mechanical, Packaging, and Orderable Information	64

4 Revision History

Changes from Revision A (March 2017) to Revision B	Page
• Changed V_{OH} Test Conditions From: "Default $V_{SPI} = 1.8\text{ V}$ " To: "Default $V_{SPI} = 3\text{ V}$ " in <i>Electrical Characteristics: Digital Input</i> table	12
• Changed text From: "output 1.8 V logic levels..." To: "output 3 V logic levels..." in section <i>SPI</i>	31
• Changed text From: "output 1.8 V logic levels..." To: "output 3 V logic levels..." in section <i>SPI</i>	54

Changes from Original (December 2015) to Revision A	Page
• Changed 0.1: 1.8 V (default) to 0.1: 3.0 V (default) in Table 13	35
• Changed 11: 3.0 V To: 11: 1.8 V in Table 13	35

5 Pin Configuration and Functions

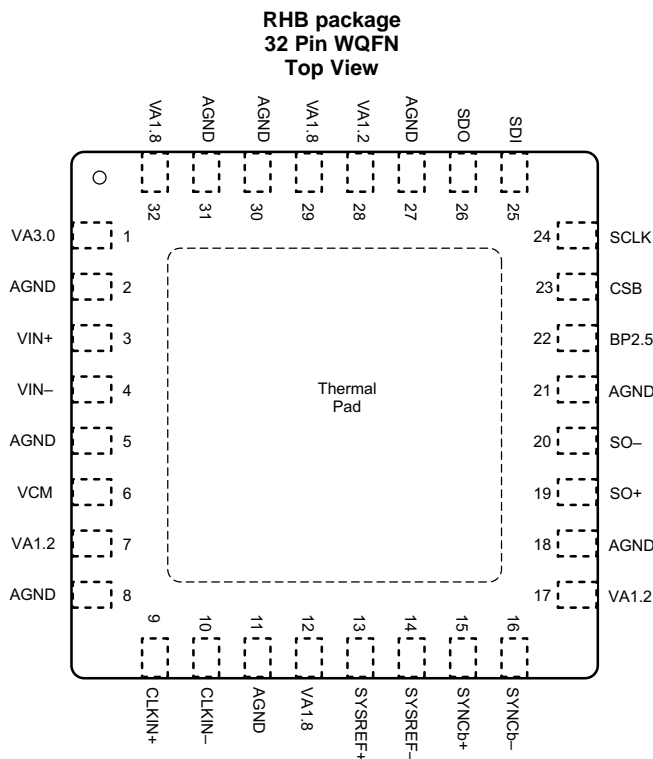

Exposed pad on bottom of package

Pin Functions

PIN		TYPE OR DIAGRAM	DESCRIPTION
NAME	NO.		
AGND	2, 5, 8, 11, 18, 21, 27, 30, 31	Analog ground	Analog ground Must be connected to a solid ground reference plane under the device.
BP2.5	22	Bypass pins	Capacitive bypassing pin for internally regulated 2.5-V supply This pin must be decoupled to AGND with a 0.1- μ F and a 10- μ F capacitor located close to the pin.
CLKIN+	9		Differential device clock input pins Each pin is internally terminated to a DC bias with a 50- Ω resistor for a 100- Ω total internal differential termination. AC coupling is required for coupling the clock input to these pins if the clock driver cannot meet the common-mode requirements. Sampling occurs on the rising edge of the differential signal (CLKIN+) - (CLKIN-).
CLKIN-	10		

Pin Functions (continued)

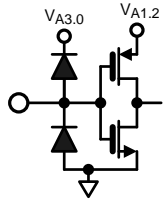
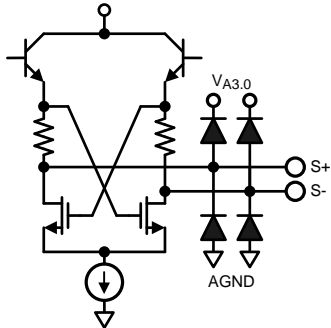
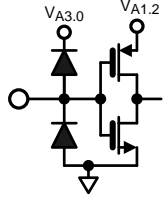
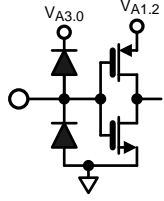
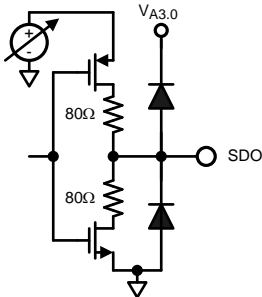
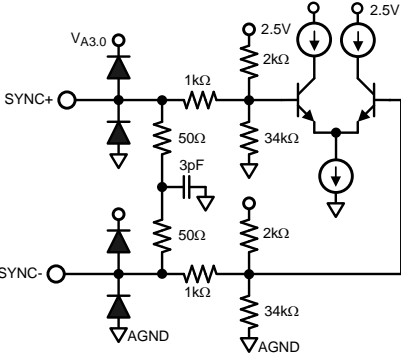
PIN		TYPE OR DIAGRAM	DESCRIPTION
NAME	NO.		
CSB	23		<p>SPI chip select pin</p> <p>When this signal is asserted, SCLK is used to clock the input serial data on the SDI pin or output serial data on the SDO pin. When this signal is de-asserted, the SDO pin is high impedance and the input data is ignored. Active low. A 10 kΩ pull-up resistor to a supply corresponding to the CSB drive logic level is recommended to prevent undesired activation of the SPI bus. Compatible with 1.2- to 3-V CMOS logic levels.</p>
SO+	19		<p>Differential high speed serial data lane pins</p> <p>These pins must be AC coupled to the receiving device. The differential trace routing from these pins must maintain a 100-Ω characteristic impedance.</p>
SO-	20		
SCLK	24		<p>SPI serial clock pin</p> <p>Serial data is shifted into and out of the device synchronous with this clock signal. Compatible with 1.2- to 3-V CMOS logic levels.</p>
SDI	25		<p>SPI data input pin</p> <p>Serial data is shifted into the device on this pin while the CSB signal is asserted. Compatible with 1.2- to 3-V CMOS logic levels.</p>
SDO	26		<p>SPI data output pin</p> <p>Serial data is shifted out of the device on this pin during a read command while CSB is asserted. The output logic level is configurable as 1.2, 1.8, 2.5, or 3 V. The output level must be configured after power up and before performing a read command. See the Register Descriptions for configuration details.</p>
SYNCb+	15		<p>Differential SYNCb signal input pins</p> <p>DC coupling is required for coupling the SYNCb signal to these pins. Each pin is internally terminated to the DC bias with a large resistor. An internal 100-Ω differential termination is provided therefore an external termination is not required. Additional resistive components in the input structure give the SYNCb input a wide input common-mode range. The SYNCb signal is active low and therefore asserted when the voltage at SYNCb+ is less than at SYNCb-. If JESD204B sync- signals are directed via SPI (with SYNC_SEL=1), then SYNCb+ and SYNCb- may remain not connected.</p>
SYNCb-	16		

Pin Functions (continued)

PIN		TYPE OR DIAGRAM	DESCRIPTION
NAME	NO.		
SYSREF+	13		<p>Differential SYSREF signal input pins Each pin is internally terminated to a DC bias with a 1-kΩ resistor. An external 100-Ω differential termination must always be provided. AC coupling using capacitors is required for coupling the SYSREF signal to these pins if the clock driver cannot meet the common-mode requirements. In the case of AC coupling, the external termination must be placed on the source side of the coupling capacitors.</p>
SYSREF-	14		
VA1.2	7, 17, 28	Supply input pin	1.2-V analog power supply pins These pins must be connected to a quiet source and decoupled to AGND with a 0.1-μF and 0.01-μF capacitor located close to each pin.
VA1.8	12, 29, 32	Supply input pin	1.8-V analog power supply pins These pins must be connected to a quiet source and decoupled to AGND with a 0.1-μF and 0.01-μF capacitor located close to each pin.
VA3.0	1	Supply input pin	3-V analog power supply pin This pin must be connected to a quiet source and decoupled to AGND with a 0.1-μF and 0.01-μF capacitor located close to the pin.
VCM	6		Input interface common mode voltage This pin must be bypassed to AGND with low equivalent series inductance (ESL) 0.1-μF capacitors. One capacitor should be placed as close to the pin as possible and additional capacitors placed at the bias load points. 10-μF capacitors should also be placed in parallel. TI recommends to use VCM to provide the common mode voltage for the differential analog inputs. The input common mode bias is provided internally for the ADC input; therefore, external use of VCM is recommended, but not strictly required. The recommended bypass capacitors are always required.
VIN+	3		<p>Differential analog input pins Each input pin is terminated to the internal common mode reference with a resistor for an internal differential termination. External resistors that terminate to the common-mode voltage bias are recommended but not strictly required. The total recommended differential resistive termination (including the internal 200 Ω termination) is recommended to be between 50 Ω and 200 Ω.</p>
VIN-	4		
		Exposed thermal pad	Exposed thermal pad The exposed pad must be connected to the AGND ground plane electrically and with good thermal dissipation properties to achieve rated performance.

6 Specifications

6.1 Absolute Maximum Ratings

 over operating free-air temperature range (unless otherwise noted) ⁽¹⁾

		MIN	MAX	UNIT		
Supply Voltage	V _{A3.0}	-0.3	4.2	V		
	V _{A1.8}	-0.3	2.35	V		
	V _{A1.2}	-0.3	1.55	V		
Voltage at:	VIN+, VIN-	V _{CM} - 0.75 ⁽²⁾	V _{CM} + 0.75	V		
	VCM	-0.3	V _{A3.0} + 0.3, not to exceed 4.2 V	V		
	SCLK, SDI, CSb	-0.3	V _{A3.0} + 0.3, not to exceed 4.2 V	V		
	SDO	-0.3	V _{SPI} + 0.3, not to exceed 4.2 V	V		
	CLKIN+, CLKIN-, SYSREF+, SYSREF-	-0.3	1.55	V		
	SYNC+, SYNC-	-0.3	V _{BP2.5} + 0.3	V		
	BP2.5	-0.3	3.2	V		
	SO+, SO-	-0.3	V _{BP2.5} + 0.3	V		
Input current at any pin ⁽³⁾				5	mA	
T _J	Operating junction temperature ⁽⁴⁾			125	°C	
T _{stg}	Storage temperature range			-65	150	°C

- (1) Stresses beyond those listed under *Absolute Maximum Ratings* may cause permanent damage to the device. These are stress ratings only, which do not imply functional operation of the device at these or any other conditions beyond those indicated under *Recommended Operating Conditions*. Exposure to absolute-maximum-rated conditions for extended periods may affect device reliability.
- (2) V_{CM} refers to the voltage bias present at the VCM output. The Absolute Maximum Rating for the VIN+ and VIN- inputs may extend down to -0.3V for the purpose of the initial power-up transient only. Forcing these pins to a voltage lower than V_{CM} - 0.75 for an extended time may reduce the operating lifetime of the device.
- (3) When the input voltage at any pin exceeds the V_{A3.0} power supply (that is V_{IN} > V_{A3.0} or V_{IN} < AGND) the current at that pin should be limited to ±5 mA. The ±50-mA maximum package input current rating limits the number of pins that can safely exceed the power supplies with an input current of ±5 mA to 10 pins.
- (4) Prolonged use at this temperature may increase the device failure-in-time (FIT) rate.

6.2 ESD Ratings

			VALUE	UNIT
V _(ESD)	Electrostatic discharge	Human body model (HBM), per ANSI/ESDA/JEDEC JS-001 ⁽¹⁾	±2500	V
		Charged device model (CDM), per JEDEC specification JESD22-C101 ⁽²⁾	±1000	

- (1) JEDEC document JEP155 states that 500-V HBM allows safe manufacturing with a standard ESD control process.
- (2) JEDEC document JEP157 states that 250-V CDM allows safe manufacturing with a standard ESD control process.

6.3 Recommended Operating Conditions

Operation of the device beyond the recommended operating ratings is not recommended as it may degrade the device lifetime.

		MIN	MAX	UNIT
T _{A-MIN}	Specified temperature minimum, ambient air.	-40		°C
T _{A-MAX}	Specified temperature maximum, ambient air. ⁽¹⁾		85	°C
T _{P-MAX}	Specified temperature maximum, measured at the device's footprint thermal pad on the printed circuit board.		105	°C
T _J	Operating junction temperature ⁽²⁾		106	°C

- (1) This device may be operated above the maximum ambient temperature (T_{A-MAX}) up to the value of T_{P-MAX} as long as the maximum temperature at the device's footprint thermal pad on the printed circuit board remains less than T_{P-MAX}.
- (2) The recommended maximum operating junction temperature assumes the junction to package bottom thermal resistance, R_{θJC(bottom)} = 1.1°C/W, the thermal resistance of the device thermal pad connection to the PCB footprint is negligible, and the recommended maximum temperature at the PCB footprint thermal pad, T_{P-MAX}, is satisfied.

6.4 Thermal Information

THERMAL METRIC ⁽¹⁾		RHB (WQFN)	UNIT
		(32 PINS)	
R _{θJA}	Thermal resistance, junction to ambient	31.4	°C/W
R _{θJC(top)}	Thermal resistance, junction to package top	50.2	
R _{θJC(bottom)}	Thermal resistance, junction to package bottom	1.1	
R _{θJB}	Thermal resistance, junction to board	5.1	
φ _{JT}	Characterization parameter, junction to package top	0.2	
φ _{JB}	Characterization parameter, junction to board	5.1	

(1) For more information about traditional and new thermal metrics, see the [Semiconductor and IC Package Thermal Metrics](#) application report.

6.5 Electrical Characteristics: Static Converter Performance

Unless otherwise noted, these specifications apply for V_{A3.0} = 3 V; V_{A1.8} = 1.8 V; V_{A1.2} = 1.2 V; F_{CLKIN} = F_S = 250 MSPS; external differential resistive termination at ADC input is 66 Ω. Typical values are at T_A = 25°C, unless otherwise noted. Limit values specified for the temperature range T_{A-MIN} = -40°C to T_{P-MAX} = 105°C.

PARAMETER		TEST CONDITIONS	MIN	TYP	MAX	UNIT
RESOLUTION	Bit resolution of ADC core			14		Bits
FSR	Full scale range Differential peak-to-peak			1.7		V _{pp}
G _{VAR}	Gain variation 1-sigma variation of full scale range across multiple units			±0.05		dB
V _{OFF}	Input referred voltage offset			±3		mV
DNL	Differential non-linearity			+0.27 -0.18		LSB
INL	Integral non-linearity			+1 -0.9		LSB

6.6 Electrical Characteristics: Dynamic Converter Performance

Unless otherwise noted, these specifications apply for V_{A3.0} = 3 V; V_{A1.8} = 1.8 V; V_{A1.2} = 1.2 V; F_{CLKIN} = F_S = 250 MSPS; external differential resistive termination at ADC input is 66 Ω. CLKIN± input is a 2 V_{p-p} differential sinusoid. Typical values are at T_A = 25°C, unless otherwise noted. Limit values specified for the temperature range T_{A-MIN} = -40°C to T_{P-MAX} = 105°C.

PARAMETER		TEST CONDITIONS	MIN	TYP	MAX	UNIT
BW _{3dB}	3-dB bandwidth Frequency at which the voltage input to digital output response deviates by 3 dB compared to low frequencies for a low impedance differential signal applied at the input pins. Includes 0.5-nH parasitic inductance in series with each pin of the differential analog input.			800		MHz
SNR	Signal-to-noise ratio, integrated across entire Nyquist bandwidth					dBFS
	Input = 10 MHz, -3 dBFS			71.1		
	Input = 70 MHz, -3 dBFS			70.9		
	Input = 170 MHz, -3 dBFS			70.5		
	Input = 240 MHz, -3 dBFS		68.3	70.1		
	Input = 240 MHz, -40 dBFS			71.1		
Input = 300 MHz, -3 dBFS			69.7			

Electrical Characteristics: Dynamic Converter Performance (continued)

Unless otherwise noted, these specifications apply for $V_{A3.0} = 3\text{ V}$; $V_{A1.8} = 1.8\text{ V}$; $V_{A1.2} = 1.2\text{ V}$; $F_{CLKIN} = F_S = 250\text{ MSPS}$; external differential resistive termination at ADC input is $66\ \Omega$. CLKIN± input is a 2 Vp-p differential sinusoid. Typical values are at $T_A = 25^\circ\text{C}$, unless otherwise noted. Limit values specified for the temperature range $T_{A-MIN} = -40^\circ\text{C}$ to $T_{P-MAX} = 105^\circ\text{C}$.

	PARAMETER	TEST CONDITIONS	MIN	TYP	MAX	UNIT
SINAD	Signal-to-noise and distortion ratio, integrated across Nyquist bandwidth					dBFS
	Input = 10 MHz, -3 dBFS			71.0		
	Input = 70 MHz, -3 dBFS			70.8		
	Input = 170 MHz, -3 dBFS			70.0		
	Input = 240 MHz, -3 dBFS			70.0		
	Input = 240 MHz, -40 dBFS			71.0		
	Input = 300 MHz, -3 dBFS			69.4		
ENOB	Signal-to-noise and distortion ratio, integrated across Nyquist bandwidth					Bits
	Input = 10 MHz, -3 dBFS			11.5		
	Input = 70 MHz, -3 dBFS			11.5		
	Input = 170 MHz, -3 dBFS			11.3		
	Input = 240 MHz, -3 dBFS			11.3		
NSD	Noise spectral density, average NSD across Nyquist bandwidth					dBFS/Hz
	Input = 10 MHz, -3 dBFS			-152.1		
	Input = 70 MHz, -3 dBFS			-151.9		
	Input = 170 MHz, -3 dBFS			-151.5		
	Input = 240 MHz, -3 dBFS			-151.1		
	Input = 240 MHz, -40 dBFS			-152.1		
SFDR	Spurious free dynamic range, single tone					dBFS
	Input = 10 MHz, -3 dBFS			93		
	Input = 70 MHz, -3 dBFS			92		
	Input = 170 MHz, -3 dBFS			80		
	Input = 240 MHz, -3 dBFS		75	87		
HD2	2 nd order harmonic distortion					dBFS
	Input = 10 MHz, -3 dBFS			-95		
	Input = 70 MHz, -3 dBFS			-95		
	Input = 170 MHz, -3 dBFS			-92		
	Input = 240 MHz, -3 dBFS		-75	-90		
HD3	3 rd order harmonic distortion					dBFS
	Input = 10 MHz, -3 dBFS			-95		
	Input = 70 MHz, -3 dBFS			-95		
	Input = 170 MHz, -3 dBFS			-80		
	Input = 240 MHz, -3 dBFS		-75	-87		
	Input = 300 MHz, -3 dBFS			-86		

Electrical Characteristics: Dynamic Converter Performance (continued)

Unless otherwise noted, these specifications apply for $V_{A3.0} = 3\text{ V}$; $V_{A1.8} = 1.8\text{ V}$; $V_{A1.2} = 1.2\text{ V}$; $F_{CLKIN} = F_S = 250\text{ MSPS}$; external differential resistive termination at ADC input is $66\ \Omega$. $CLKIN_{\pm}$ input is a 2 V_{p-p} differential sinusoid. Typical values are at $T_A = 25^{\circ}\text{C}$, unless otherwise noted. Limit values specified for the temperature range $T_{A-MIN} = -40^{\circ}\text{C}$ to $T_{P-MAX} = 105^{\circ}\text{C}$.

	PARAMETER	TEST CONDITIONS	MIN	TYP	MAX	UNIT
Non HD2, HD3	Largest spurious tone, not including DC, HD2 or HD3					dBFS
	Input = 10 MHz, -3 dBFS			-95		
	Input = 70 MHz, -3 dBFS			-95		
	Input = 170 MHz, -3 dBFS			-92		
	Input = 240 MHz, -3 dBFS		-80	-92		
	Input = 300 MHz, -3 dBFS			-92		
IMD3	Third-order intermodulation, dual tone					dBFS
	Tone 1 = 235 MHz, -10 dBFS Tone 2 = 240 MHz, -10 dBFS			-94		

6.7 Electrical Characteristics: Power Supply

Unless otherwise noted, these specifications apply for $V_{A3.0} = 3\text{ V}$; $V_{A1.8} = 1.8\text{ V}$; $V_{A1.2} = 1.2\text{ V}$; $F_{CLKIN} = F_S = 250\text{ MSPS}$. Typical values are at $T_A = 25^\circ\text{C}$, unless otherwise noted. Limit values specified for the temperature range $T_{A-MIN} = -40^\circ\text{C}$ to $T_{P-MAX} = 105^\circ\text{C}$.

PARAMETER		TEST CONDITIONS	MIN	TYP	MAX	UNIT
$V_{A3.0}$	3.0V analog voltage supply		2.85	3.0	3.45	V
$V_{A1.8}$	1.8V analog voltage supply		1.7	1.8	1.9	V
$V_{A1.2}$	1.2V analog voltage supply		1.15	1.2	1.25	V
$I_{A3.0}$	$V_{A3.0}$ supply current consumption			95		mA
$I_{A1.8}$	$V_{A1.8}$ supply current consumption			112		mA
$I_{A1.2}$	$V_{A1.2}$ supply current consumption			78		mA
P_T	Total power consumption of the $V_{A3.0}$, $V_{A1.8}$, $V_{A1.2}$ supplies ⁽¹⁾	Normal operation ⁽²⁾		584	600	mW
		Power consumption during power-down state, external clock active		38		
		Power consumption during sleep state, external clock active		38		
$V_{BP2.5}$	BP2.5 bias voltage	Do not load the BP2.5 pin		2.65		V
	Supply sensitivity to noise Power of spectral spur resulting from a 100-mV sinusoidal signal modulating a supply at 500 kHz. Analog input is a -3 dBFS 150-MHz single tone. In all cases, the spur appears as part of a pair symmetric about the fundamental that scales proportionally with the fundamental amplitude.					dBFS
	$V_{A3.0}$			-72.5		
	$V_{A1.8}$			-58.0		
	$V_{A1.2}$			-37.7		

(1) Power values indicate consumption during normal conversion assuming an established JESD204 link.

(2) The power limit applies to an ambient temperature and board thermal pad temperature of 25°C .

6.8 Electrical Characteristics: Analog Interface

Unless otherwise noted, these specifications apply for $V_{A3.0} = 3\text{ V}$; $V_{A1.8} = 1.8\text{ V}$; $V_{A1.2} = 1.2\text{ V}$; $F_{CLKIN} = F_S = 250\text{ MSPS}$; external differential resistive termination at ADC input is $66\ \Omega$. Typical values are at $T_A = 25^\circ\text{C}$. Limit values specified for the temperature range $T_{A-MIN} = -40^\circ\text{C}$ to $T_{P-MAX} = 105^\circ\text{C}$.

PARAMETER		TEST CONDIONS	MIN	TYP	MAX	UNIT
V_{CM}	Input common mode voltage reference voltage at the VCM pin Varies with temperature			1.6		V
I_{VCM}	Input common mode voltage reference current sourcing or sinking on VCMA or VCMB pins. ⁽¹⁾				1	mA
V_{CM-OFF}	Input common mode voltage offset range Allowable difference between the common mode applied to the analog input and the bias voltage at the VCM bias pin.			50		mV
R_{IN}	Input termination resistance Differential			200		Ω
C_{IN}	Input capacitance, differential			3.7		pF

(1) This parameter is verified by design.

6.9 Digital Input Characteristics

Unless otherwise noted, these specifications apply for $V_{A3.0} = 3\text{ V}$; $V_{A1.8} = 1.8\text{ V}$; $V_{A1.2} = 1.2\text{ V}$; $F_{CLKIN} = F_S = 250\text{ MSPS}$. Typical values are at $T_A = 25^\circ\text{C}$. Limit values specified for the temperature range $T_{A-MIN} = -40^\circ\text{C}$ to $T_{P-MAX} = 105^\circ\text{C}$.

PARAMETER	TEST CONDITIONS	MIN	TYP	MAX	UNIT
CLKIN+/-					
V_{ID-MAX}	Maximum Input differential voltage ⁽¹⁾⁽²⁾ Differential peak voltage			1000	mV
V_{ID-MIN}	Minimum Input differential voltage ⁽¹⁾ Differential peak voltage		250		mV
dV_{SS}/dt	Recommended minimum edge slew rate at the zero crossing ⁽¹⁾		1		V/ns
$V_{IS-BIAS}$	Input offset voltage internal bias ⁽¹⁾ Internally biased		0.5		V
V_{IS-IN}	Externally applied input offset voltage ⁽²⁾⁽³⁾ Allowable common mode voltage range for DC coupled interfaces		0.5 ± 0.1		V
Zrdiff	Differential termination resistance at DC ⁽⁴⁾		100		Ω
Ztt	Common-mode bias source impedance ⁽⁴⁾⁽³⁾		11		k Ω
C_T	Differential termination capacitance ⁽³⁾		1.5		pF
SYSREF+/-					
V_{ID-MAX}	Maximum Input differential voltage ⁽¹⁾⁽²⁾ Differential peak voltage			1000	mV
V_{ID-MIN}	Minimum Input differential voltage ⁽¹⁾ Differential peak voltage		250		mV
$V_{IS-BIAS}$	Input offset voltage bias ⁽¹⁾ Internally biased		0.5		V
V_{IS-IN}	Externally applied input offset voltage ⁽²⁾⁽³⁾ Allowable common mode voltage range for DC coupled interfaces		0.5 ± 0.1		V
Zrdiff	Differential termination resistance at DC ⁽⁴⁾		2.2		k Ω
Ztt	Common-mode bias source impedance ⁽⁴⁾⁽³⁾		11		k Ω
C_T	Differential termination capacitance ⁽⁴⁾⁽³⁾		0.8		pF
SYNCb+/-					
V_{ID}	Input differential voltage ⁽¹⁾⁽²⁾ Differential peak voltage		350		mV
V_{IS-IN}	Externally applied input offset voltage ⁽¹⁾⁽²⁾		1.25 ± 0.75		V
Zrdiff	Differential termination resistance ⁽⁴⁾		110		Ω
C_T	Differential termination capacitance ⁽⁴⁾⁽³⁾		1.0		pF

- (1) Specification applies to the electrical level diagram of [Figure 1](#)
- (2) The voltage present at the pins should not exceed Absolute Maximum limits
- (3) This parameter is verified by design.
- (4) Specification applies to the electrical circuit diagram of [Figure 2](#)

6.10 Electrical Characteristics: Serial Data Output Interface

Unless otherwise noted, these specifications apply for $V_{A3.0} = 3\text{ V}$; $V_{A1.8} = 1.8\text{ V}$; $V_{A1.2} = 1.2\text{ V}$; $F_{CLKIN} = F_S = 250\text{ MSPS}$. Typical values are at $T_A = 25^\circ\text{C}$.

PARAMETER	TEST CONDITIONS	MIN	TYP	MAX	UNIT
SERIAL LANE OUTPUT CHARACTERISTICS (SO)					
V_{OD}	Output differential voltage ⁽¹⁾ Differential peak-peak values. Assumes ideal 100- Ω load. De-emphasis disabled. Configurable via SPI.		570 660 750 840 930 1030 1130 1200		mV
I_{SC}	Short circuit current. SO+ terminal shorted to GND during logic high output signal state. V_{OD} and Rdeemp configured to default values.		19		mA
Z _{diff}	Differential output impedance at DC. ⁽²⁾ V_{OD} configured to default value.		100		Ω
RL _{diff}	Differential output return loss magnitude Relative to 100 Ω ; For frequencies between 100 MHz and $0.75 \cdot \text{Baud_Rate}$ (5.5 GHz max); V_{OD} and Rdeemp configured to default values.		-11		dB
Rdeemp	Transmitter de-emphasis values V_{OD} configured to 4. Configurable via SPI.		0 1.4 3.4 4.9 5.9 7.4 8.9 12.1		dB

(1) Specification applies to the electrical level diagram of [Figure 3](#)

(2) Specification applies to the electrical circuit diagram of [Figure 4](#)

6.11 Electrical Characteristics: Digital Input

Unless otherwise noted, these specifications apply for $V_{A3.0} = 3\text{ V}$; $V_{A1.8} = 1.8\text{ V}$; $V_{A1.2} = 1.2\text{ V}$; $F_{CLKIN} = F_S = 250\text{ MSPS}$. Typical values are at $T_A = 25^\circ\text{C}$. Limit values specified for the temperature range $T_{A-MIN} = -40^\circ\text{C}$ to $T_{P-MAX} = 105^\circ\text{C}$.

PARAMETER	TEST CONDITIONS	MIN	TYP	MAX	UNIT
DIGITAL INPUT CHARACTERISTICS (SDI, SCLK, CSB)					
V_{IH}	Logical 1 input voltage ⁽¹⁾ Inputs are compatible with 1.2-V up to 3-V logic.	0.9			V
V_{IL}	Logical 0 input voltage ⁽¹⁾			0.3	V
I_{IN0}	Logic low input current		0.04		μA
I_{IN1}	Logic high input current		0.04		μA
C_{IN}	Input capacitance ⁽²⁾		2		pF
DIGITAL OUTPUT CHARACTERISTICS (SDO)					
V_{OH}	Logical 1 output voltage ⁽¹⁾⁽³⁾ $V_{SPI} = 1.2, 1.8, 2.5, \text{ or } 3\text{ V}$; Configurable via SPI. Default $V_{SPI} = 3\text{ V}$, $I_{OH} = 400\text{ }\mu\text{A}$	$V_{SPI} - 0.3$	$V_{SPI}^{(3)}$		V
V_{OL}	Logical 0 output voltage ⁽¹⁾⁽³⁾ $I_{OL} = -400\text{ }\mu\text{A}$.		0	0.3	V
+ I_{SC}	Logic high short circuit current. Applies to $V_{SPI} = 1.8\text{ V}$		18		mA
- I_{SC}	Logic low short circuit current. Applies to $V_{SPI} = 1.8\text{ V}$		14		mA

(1) Specification applies to the electrical level diagram of [Figure 5](#).

(2) This parameter is verified by design.

(3) The SPI_CFG register must be changed to a supported output logic level after power up and before a read command is executed. Until that time, the output voltage on SDO may be as high as the $V_{A3.0}$ supply during a read command. The SDO output is high-Z at all times except during a read command.

6.12 Timing Requirements

Unless otherwise noted, these specifications apply for $V_{A3.0} = 3\text{ V}$; $V_{A1.8} = 1.8\text{ V}$; $V_{A1.2} = 1.2\text{ V}$; $F_{\text{CLKIN}} = F_{\text{S}} = 250\text{ MSPS}$. $V_{\text{SPI}} = 1.8\text{ V}^{(1)}$. Typical values are at $T_{\text{A}} = 25^{\circ}\text{C}$. Limit values specified for the temperature range $T_{\text{A-MIN}} = -40^{\circ}\text{C}$ to $T_{\text{P-MAX}} = 105^{\circ}\text{C}$.

PARAMETER		TEST CONDITIONS	MIN	TYP	MAX	UNIT
ADC SAMPLING INSTANT TIMING CHARACTERISTICS						
F_{S}	Sampling Rate Equal to $F_{\text{CLKIN}} / \text{CLKDIV}$		50		250	MSPS
F_{CLKIN}	Input Clock Frequency at CLKIN Inputs					MHz
	CLKDIV = 1		50		250	
	CLKDIV = 2		100		500	
	CLKDIV = 4		200		1000	
DC	Input clock (CLKIN) duty cycle	CLKDIV = 1	30	50	70	%
		CLKDIV = 2, 4, 8 ⁽²⁾	45	50	55	
$t_{\text{LAT-ADC}}$	ADC core latency Delay from a reference sampling instant to the boundary of the internal LMFC where the reference sample is the first sample of the next transmitted multi-frame. In this device, the frame clock period is equal to the sampling clock period.			8.5		Frame clock cycles
t_{J}	Additive sampling aperture jitter Depends on input CLKIN differential edge rate at the zero crossing, dV_{SS}/dt . Tested with 5 V/ns edge rate.					fs
	CLKDIV = 1			105		
	CLKDIV = 2, 4, 8			140		
SYSREF TIMING CHARACTERISTICS						
$t_{\text{PH-SYS}}$	SYSREF assertion duration Required duration of SYSREF assertion after rising edge event		2			Frame clock cycles
$t_{\text{PL-SYS}}$	SYSREF de-assertion duration Required duration of SYSREF de-assertion after falling edge event		2			Frame clock cycles
$t_{\text{S-SYS}}$	SYSREF setup time Relative to CLKIN rising edge			430		ps
$t_{\text{H-SYS}}$	SYSREF hold time Relative to CLKIN rising edge			-100		ps
JESD204B INTERFACE LINK TIMING CHARACTERISTICS						
$t_{\text{D-LMFC}}$	SYSREF to LMFC delay Functional delay between SYSREF assertion latched and LMFC frame boundary. Depends on CLKDIV setting. Multiply the delay value by the CLKDIV factor to convert to units of CLKIN clock cycles.					Frame clock cycles
	CLKDIV = 1			3.5		
	CLKDIV = 2			4		
	CLKDIV = 4			3.75		
$t_{\text{D-K28}}$	LMFC to K28.5 delay Functional delay between the start of the first K28.5 frame during Code Group Synchronization at the serial output and the preceding LMFC frame boundary.		7	7.4	9	Frame clock cycles
		CLKDIV = 2				
		CLKDIV = 4				
		CLKDIV = 8				
$t_{\text{D-ILA}}$	LMFC to ILA delay Functional delay between the start of the first ILA frame during Initial Lane Synchronization at the serial output and the preceding LMFC frame boundary		7	7.4	9	Frame clock cycles
$t_{\text{D-DATA}}$	LMFC to valid data delay Functional delay between the start of the first valid data frame at the serial output and the preceding LMFC frame boundary.		7	7.4	9	Frame clock cycles

(1) All timing specifications for the SPI given for $V_{\text{SPI}} = 1.8\text{-V}$ logic levels and a 5-pF capacitive load on the SDO output. Timing specification may require larger margins for $V_{\text{SPI}} = 1.2\text{ V}$.

(2) This parameter is verified by design.

Timing Requirements (continued)

Unless otherwise noted, these specifications apply for $V_{A3.0} = 3\text{ V}$; $V_{A1.8} = 1.8\text{ V}$; $V_{A1.2} = 1.2\text{ V}$; $F_{CLKIN} = F_S = 250\text{ MSPS}$. $V_{SPI} = 1.8\text{ V}^{(1)}$. Typical values are at $T_A = 25^\circ\text{C}$. Limit values specified for the temperature range $T_{A-MIN} = -40^\circ\text{C}$ to $T_{P-MAX} = 105^\circ\text{C}$.

PARAMETER	TEST CONDITIONS	MIN	TYP	MAX	UNIT
$t_{H-SYNcb}$	SYNcb assertion hold time Required SYNcb hold time after assertion before de-assertion to initiate a link re-synchronization.		4		Frame clock cycles
t_{ILA}	ILA duration Duration of the ILA sequence .		4		Multi-frame clock cycles
SERIAL OUTPUT DATA TIMING CHARACTERISTICS					
F_{SR}	Serial bit rate	1.0		5.0	Gb/s
UI	Unit Interval 5.0 Gb/s Data Rate		200		ps
t_R, t_F	Edge transition rise and fall times		40		ps
DJ	Deterministic jitter Includes periodic jitter (PJ), data dependent jitter (DDJ), duty cycle distortion (DCD), and inter-symbol interference (ISI); 5.0 Gb/s data rate.		0.032		p-p UI
			6.33		p-p ps
RJ	Random jitter Assumes BER of $1e-15$ ($Q = 15.88$); 5.0 Gb/s data rate		0.118		p-p UI
			1.48		rms ps
TJ	Total jitter Sum of DJ and RJ. Assumes BER of $1e-15$ (measured $Q = 15.6$); 5.0 Gb/s data rate.		0.148		p-p UI
			29.56		p-p ps
SPI BUS TIMING CHARACTERISTICS⁽¹⁾					
f_{SCLK}	Serial clock frequency $f_{SCLK} = 1 / t_P$			20	MHz
t_{PH}	SCLK pulse width – high	10			ns
t_{PL}	SCLK pulse width – low	10			ns
t_{SSU}	SDI input data setup time	5			ns
t_{SH}	SDI input data hold time	5			ns
t_{ODZ}	SDO output data driven-to-3-state time			15	ns
t_{OZD}	SDO output data 3-state-to-driven time			15	ns
t_{OD}	SDO output data delay time			20	ns
t_{CSS}	CSB setup time	5			ns
t_{CSH}	CSB hold time	5			ns
t_{IAG}	Inter-access gap Minimum time CSB must be de-asserted between accesses	5			ns

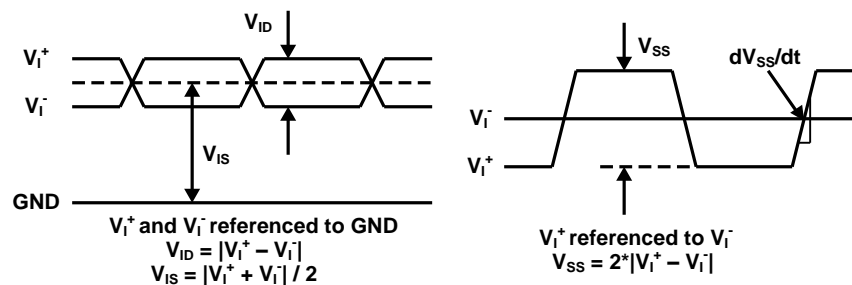

Figure 1. Electrical Level Diagram for Differential Input Signals

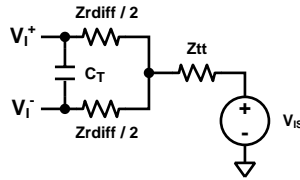

Figure 2. Simplified Electrical Circuit Diagram for Differential Input Signals

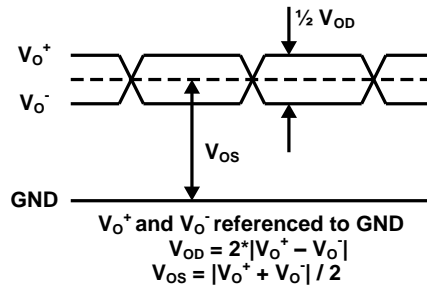

Figure 3. Electrical Level Diagram for Differential Output Signals

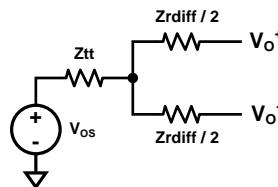

Figure 4. Electrical Circuit Diagram for Differential Output Signals

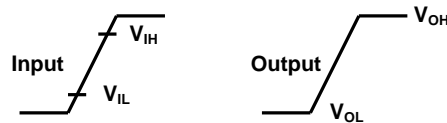

Figure 5. Electrical Level Diagram for Single-ended Digital Inputs and Outputs

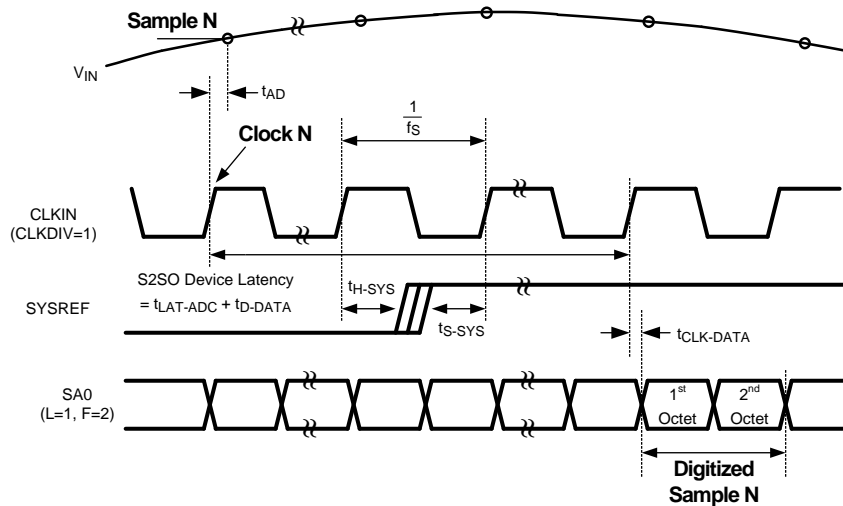
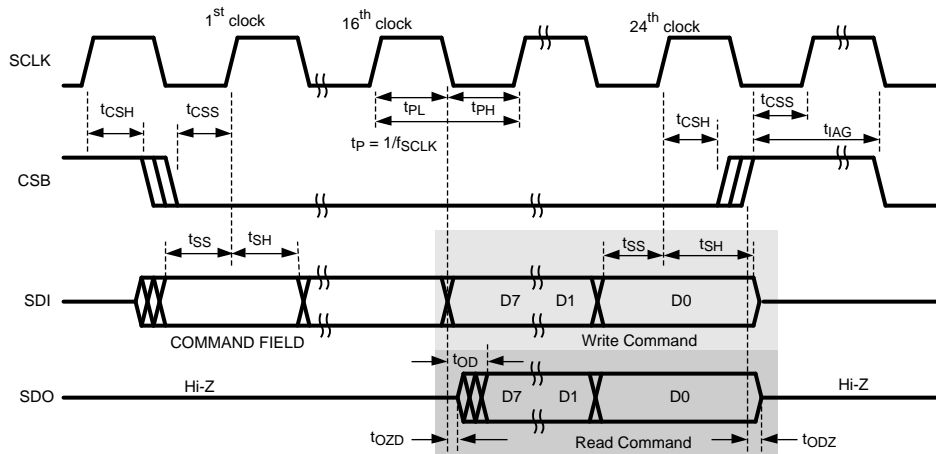
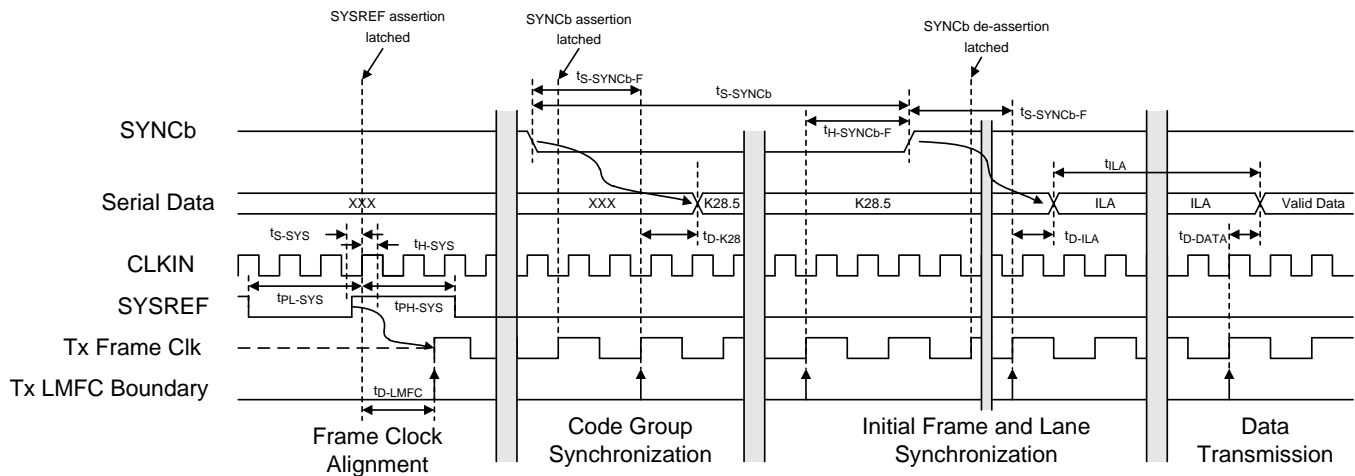

Figure 6. Sample to Data Timing Diagram

Figure 7. SPI Timing Diagram

Figure 8. JESD204B Interface Link Initialization Timing Diagram

 For more information, see the [Functional Block Diagram](#).

6.13 Typical Characteristics

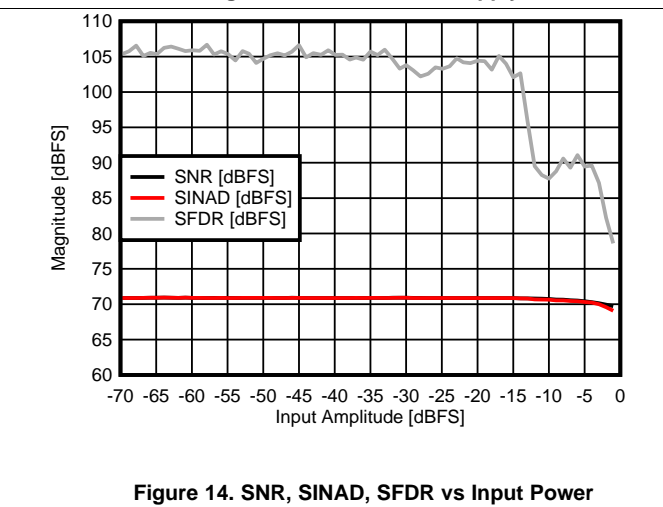
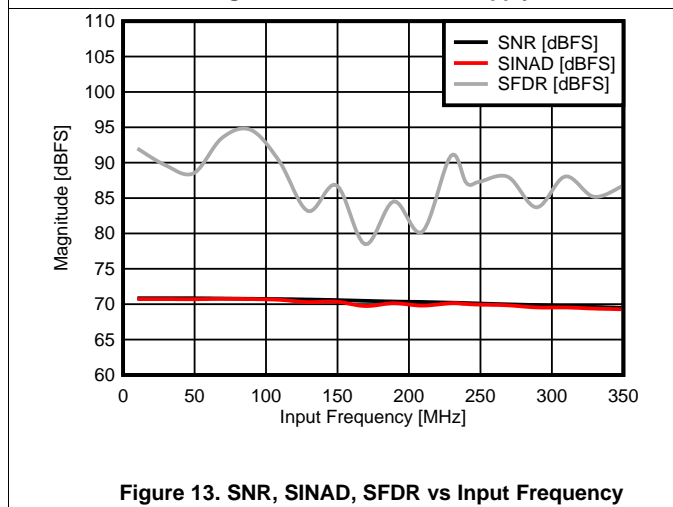
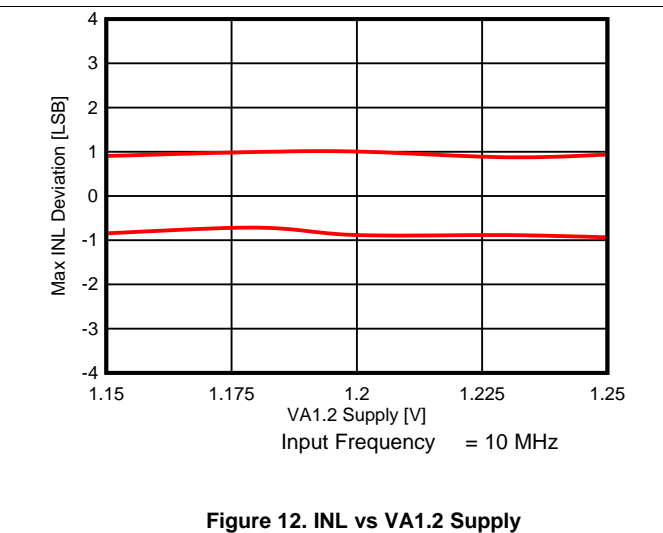
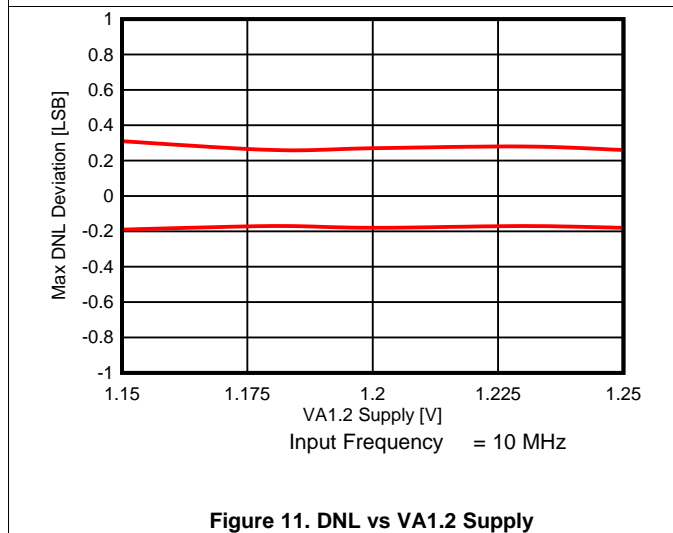
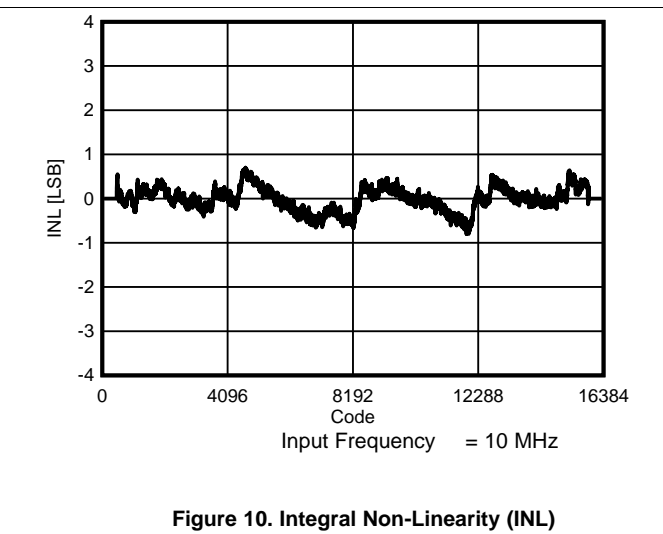
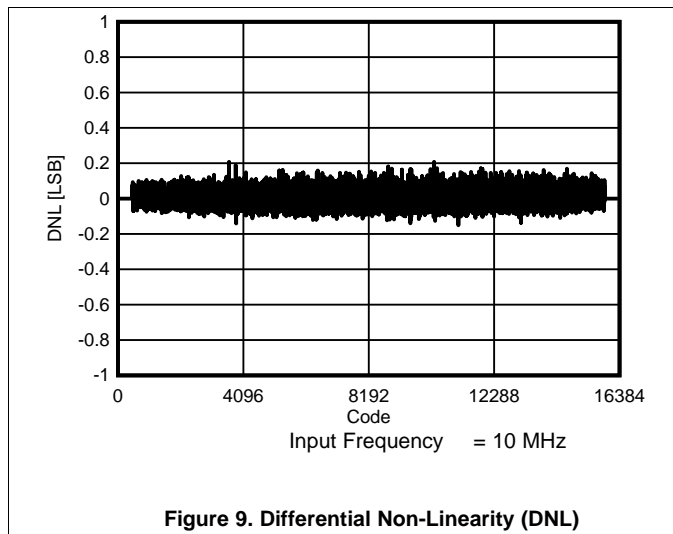
Unless otherwise noted, these specifications apply for $V_{A3.0} = 3.0\text{ V}$; $V_{A1.8} = 1.8\text{ V}$; $V_{A1.2} = 1.2\text{ V}$; $F_{CLKIN} = F_S = 250\text{ MSPS}$; 240-MHz input frequency; -3 dBFS input power. External termination at ADC input is $66\ \Omega$ differential. $CLKIN_{\pm}$ input is a 2 Vp-p differential sinusoid. Typical values are at $T_A = 25^{\circ}\text{C}$.



Typical Characteristics (continued)

Unless otherwise noted, these specifications apply for $V_{A3.0} = 3.0\text{ V}$; $V_{A1.8} = 1.8\text{ V}$; $V_{A1.2} = 1.2\text{ V}$; $F_{CLKIN} = F_S = 250\text{ MSPS}$; 240-MHz input frequency; -3 dBFS input power. External termination at ADC input is $66\ \Omega$ differential. $CLKIN_{\pm}$ input is a 2 Vp-p differential sinusoid. Typical values are at $T_A = 25^{\circ}\text{C}$.

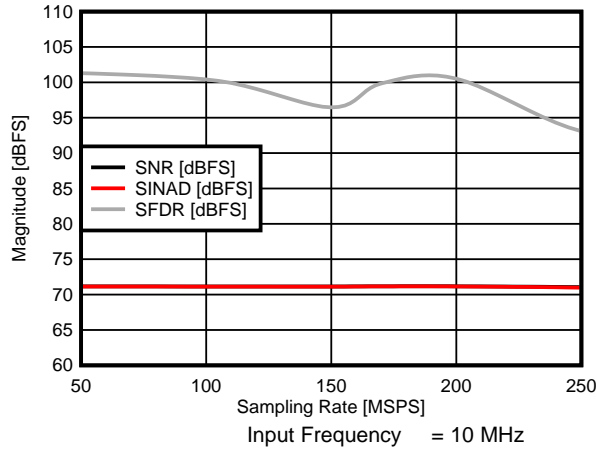

Figure 15. SNR, SINAD, SFDR vs Sampling Rate

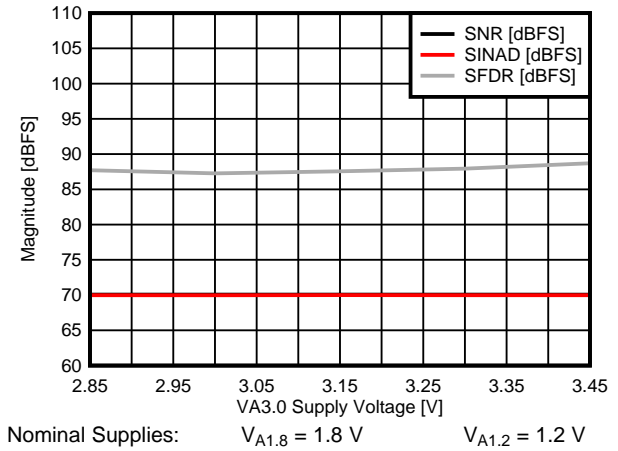

Figure 16. SNR, SINAD, SFDR vs VA3.0 Supply

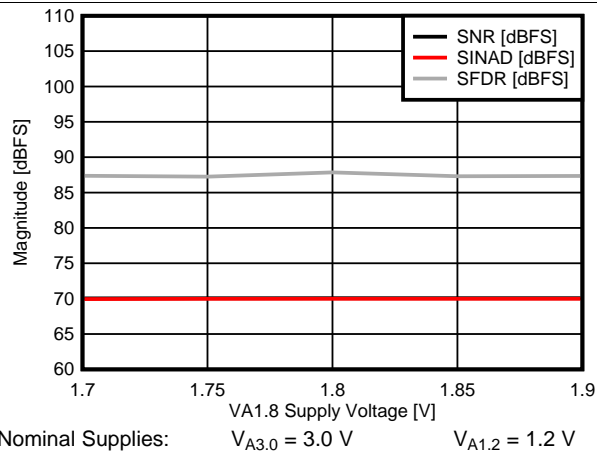

Figure 17. SNR, SINAD, SFDR vs VA1.8 Supply

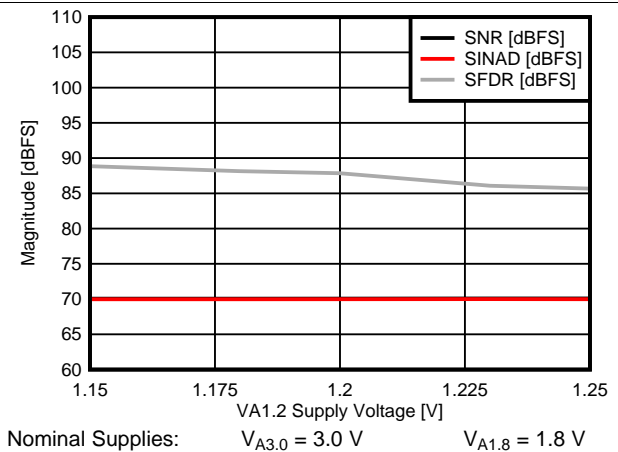

Figure 18. SNR, SINAD, SFDR vs VA1.2 Supply

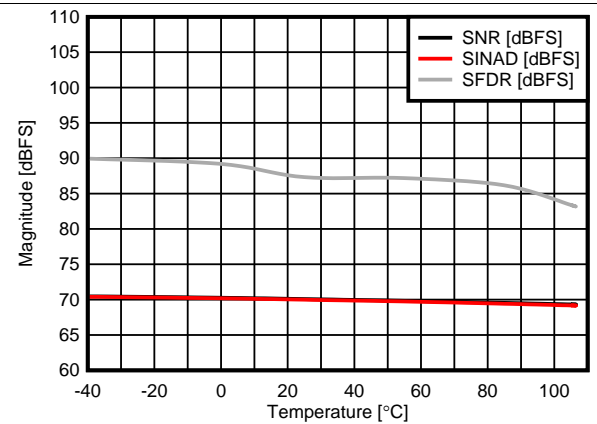

Figure 19. SNR, SINAD, SFDR vs Temperature

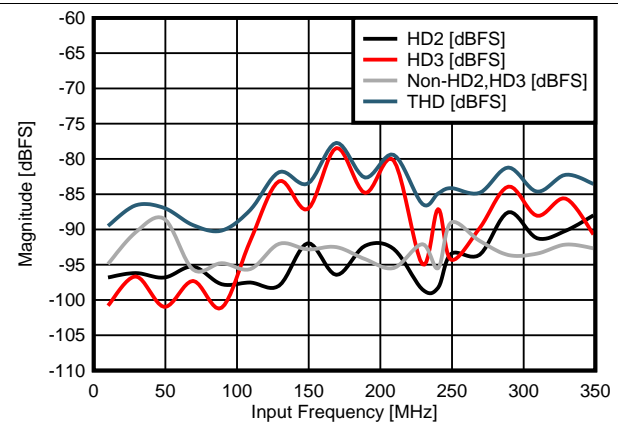

Figure 20. HD2, HD3, Non-HD2/HD3, THD vs Input Frequency

Typical Characteristics (continued)

Unless otherwise noted, these specifications apply for $V_{A3.0} = 3.0\text{ V}$; $V_{A1.8} = 1.8\text{ V}$; $V_{A1.2} = 1.2\text{ V}$; $F_{CLKIN} = F_S = 250\text{ MSPS}$; 240-MHz input frequency; -3 dBFS input power. External termination at ADC input is $66\ \Omega$ differential. $CLKIN_{\pm}$ input is a 2 Vp-p differential sinusoid. Typical values are at $T_A = 25^{\circ}\text{C}$.

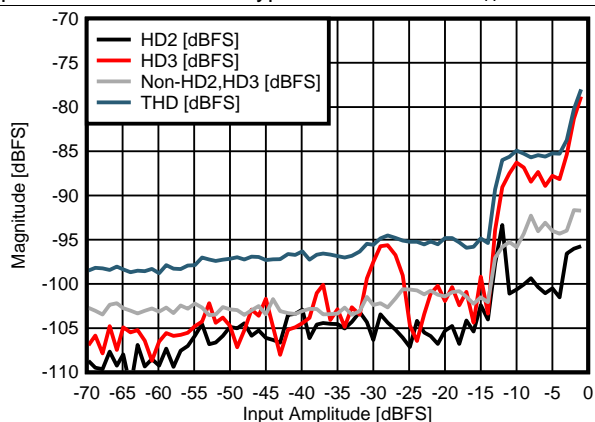

Figure 21. HD2, HD3, Non-HD2/HD3, THD vs Input Power

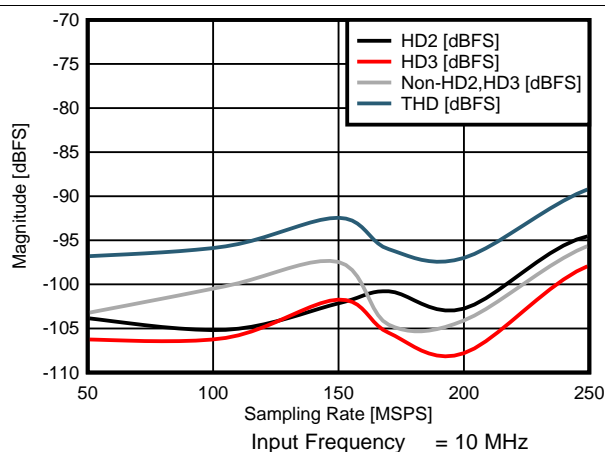

Figure 22. HD2, HD3, Non-HD2/HD3, THD vs Sampling Rate

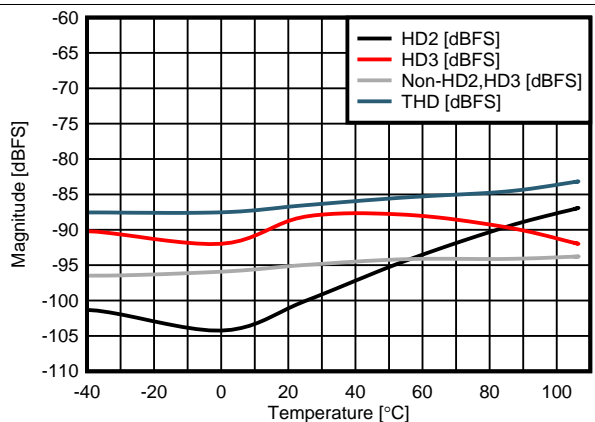

Figure 23. HD2, HD3, Non-HD2/HD3, THD vs Temperature

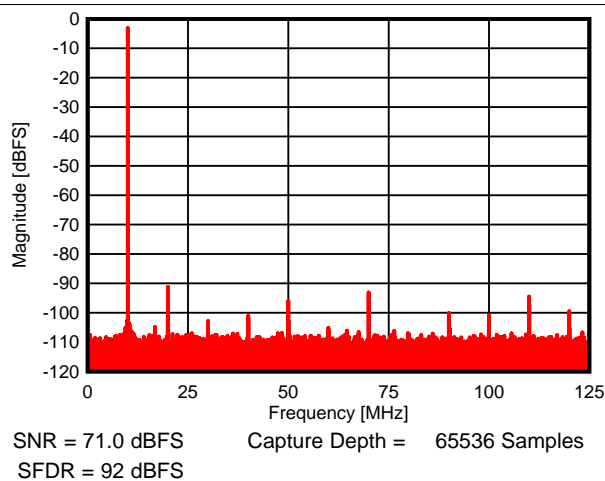

Figure 24. 1-Tone Spectrum (10 MHz)

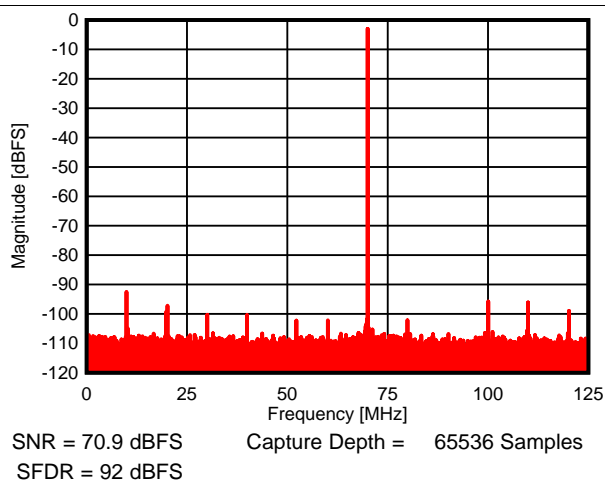

Figure 25. 1-Tone Spectrum (70 MHz)

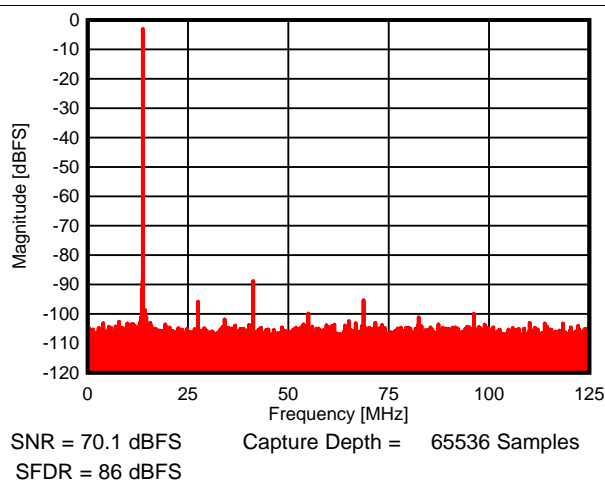
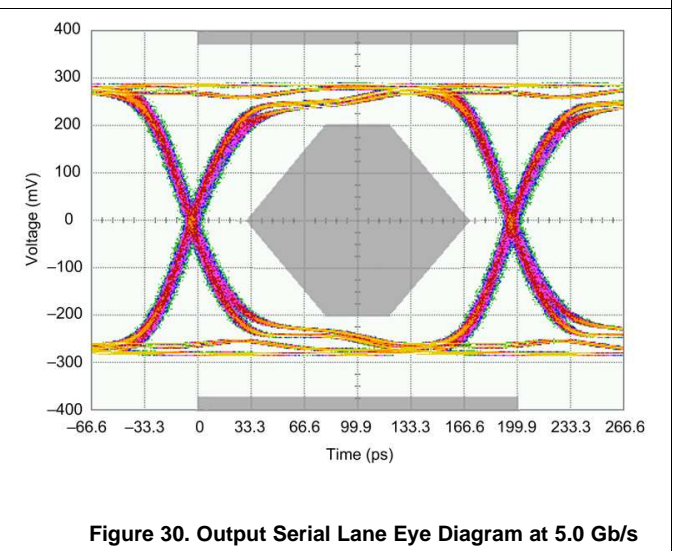
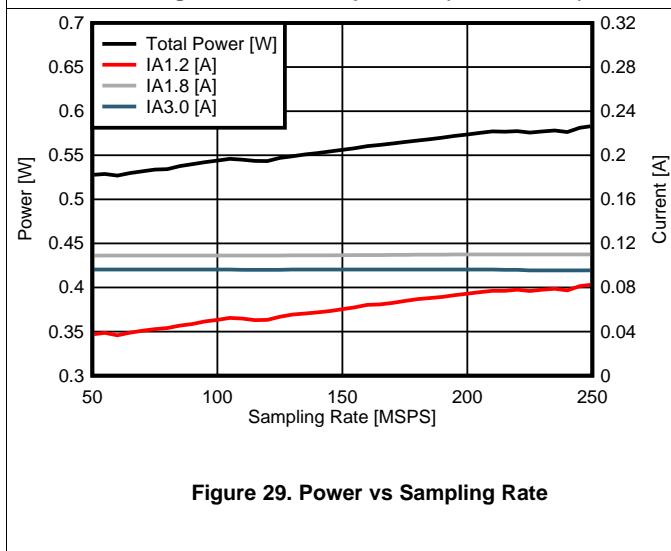
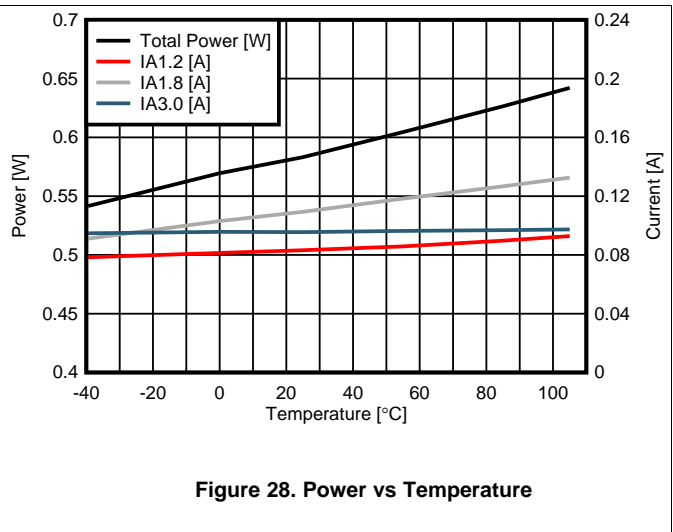
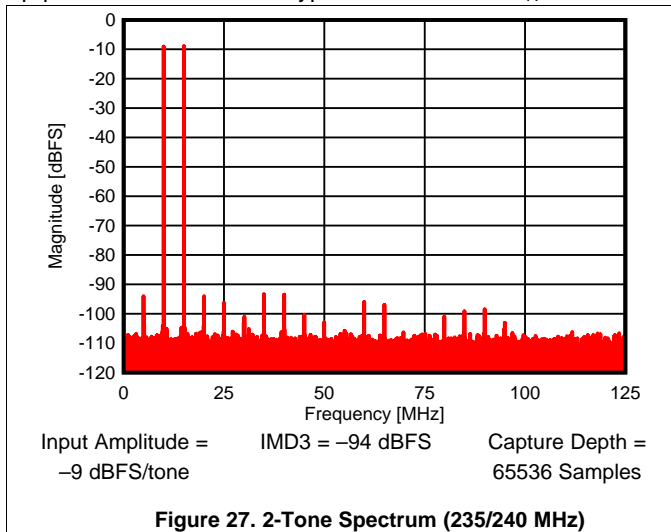

Figure 26. 1-Tone Spectrum (240 MHz)

Typical Characteristics (continued)

Unless otherwise noted, these specifications apply for $V_{A3.0} = 3.0\text{ V}$; $V_{A1.8} = 1.8\text{ V}$; $V_{A1.2} = 1.2\text{ V}$; $F_{CLKIN} = F_S = 250\text{ MSPS}$; 240-MHz input frequency; -3 dBFS input power. External termination at ADC input is $66\ \Omega$ differential. $CLKIN_{\pm}$ input is a 2 Vp-p differential sinusoid. Typical values are at $T_A = 25^{\circ}\text{C}$.



Typical Characteristics (continued)

Unless otherwise noted, these specifications apply for $V_{A3.0} = 3.0\text{ V}$; $V_{A1.8} = 1.8\text{ V}$; $V_{A1.2} = 1.2\text{ V}$; $F_{CLKIN} = F_S = 250\text{ MSPS}$; 240-MHz input frequency; -3-dBFS input power. External termination at ADC input is $66\ \Omega$ differential. $CLKIN_{\pm}$ input is a 2 Vp-p differential sinusoid. Typical values are at $T_A = 25^{\circ}\text{C}$.

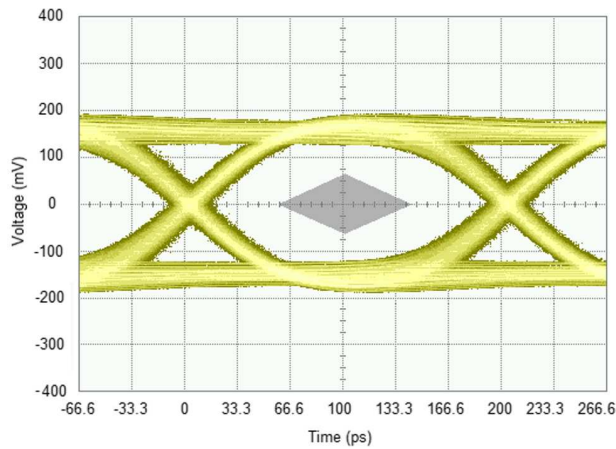

Figure 31. Transmitted Eye at Output of 20-inch, 5-mil. FR4 Microstrip at 5.0 Gb/s With Optimized De-Emphasis and Voltage Swing

7 Parameter Measurement Information

7.1 JESD204B Interface Functional Characteristics

Unless otherwise noted, these specifications apply for all supply and temperature conditions.

PARAMETER	DESCRIPTION AND TEST CONDITIONS	VALUE
LSF	Supported Configurations L = Number of lanes/converter S = Samples per frame F = Octets per frame	L = 1, S = 1, F = 2
K	Number of frames per multi-frame Configurable via SPI	
	L = 1, S = 1, F = 2	9 (min) 32 (max, default)

8 Detailed Description

8.1 Overview

The ADC14X250 device is a single channel analog-to-digital converter (ADC) composed of pipelined stages and followed by a back-end JESD204B interface. The ADC core is preceded by an input buffer and imbalance correction circuit at the analog input and is provided with the necessary reference voltages with internal drivers that require no external components. The analog input common-mode is also internally regulated.

A DC offset correction block is disabled by default, but may also be enabled at the ADC core output to remove DC offset. Processed data is passed into the JESD204B interface where the data is framed, encoded, serialized, and output on one lane per channel. Data is serially transmitted by configurable high-speed voltage mode drivers.

The sampling clock is derived from the CLKIN input via a low-noise receiver and clock divider. The CLKIN, SYSREF, and SYNCb inputs provide the device clock, sysref, and sync~ signals to the JESD204B interface, which are used to derive the internal local frame and local multi-frame clocks and establish the serial link.

Features of the ADC14X250 device are configurable through the 4-wire SPI.

8.2 Functional Block Diagram

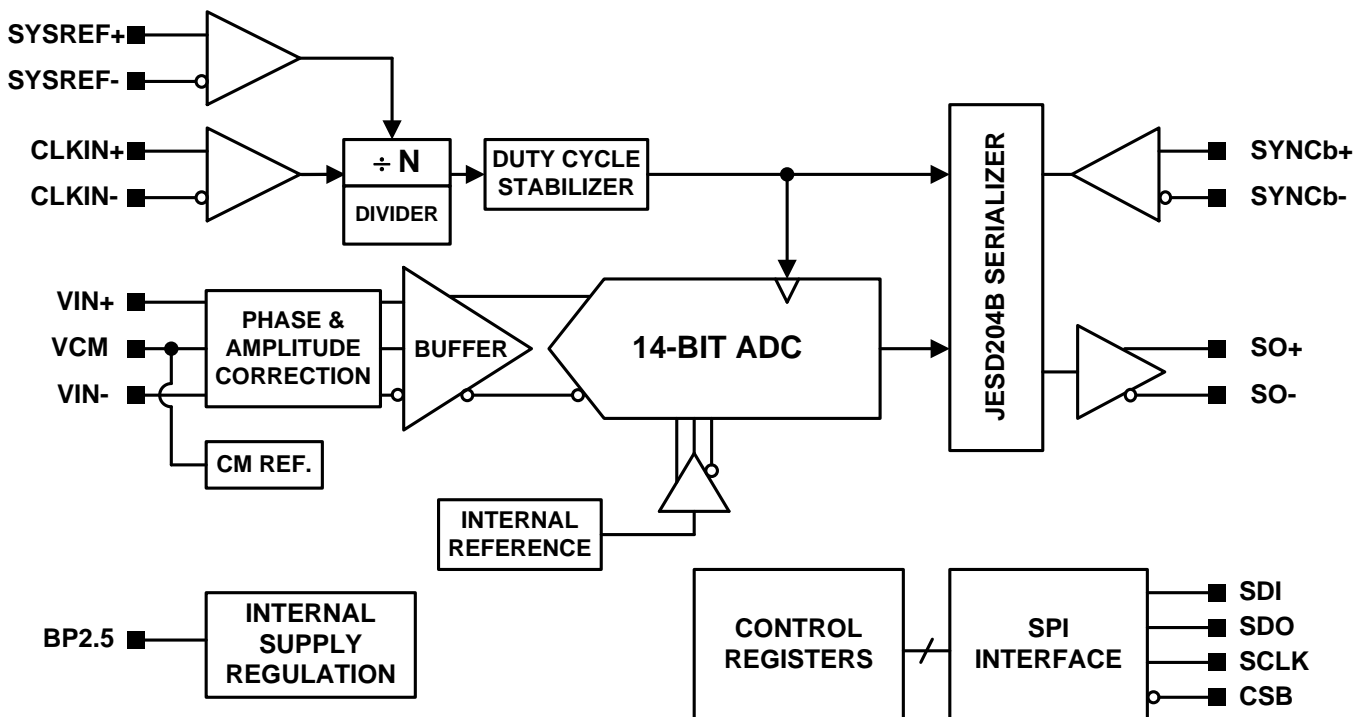

8.3 Feature Description

8.3.1 Amplitude and Phase Imbalance Correction of Differential Analog Input

The ADC performance can be sensitive to amplitude and phase imbalance of the input differential signal and therefore integrates a front-end balance correction circuit to optimize the second-order distortion (HD2) performance of the ADC in the presence of an imbalanced input signal. 4-bit control of the phase mismatch and 3-bit control of the amplitude mismatch corrects the input mismatch before the input buffer. A simplified diagram of the amplitude and phase correction circuit at the ADC input is shown in [Figure 32](#).

Feature Description (continued)

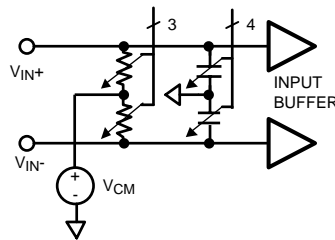

Figure 32. Simplified Input Differential Balance Correction Circuit

Amplitude correction is achieved by varying the single-ended termination resistance of each input while maintaining constant total differential resistance, thereby adjusting the amplitude at each input but leaving the differential swing constant. Phase correction, also considered capacitive balance correction, varies the capacitive load at the ADC input, thereby correcting a phase imbalance by creating a bandwidth difference between the analog inputs that minimally affects amplitude. This function is useful for correcting the balance of transformers or filters that drive the ADC analog inputs. [Figure 33](#) shows the measured HD2 resulting from an example 240-MHz imbalanced signal input into the ADC14X250 device recorded over the available amplitude and phase correction settings, demonstrating the optimization of HD2. Performance parameters in the [Electrical Characteristics: Dynamic Converter Performance](#) are characterized with the amplitude and phase correction settings in the default condition.

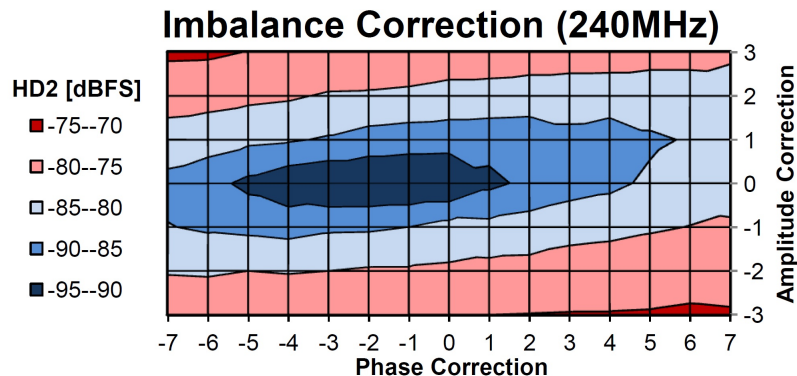

Figure 33. Gain and Phase Imbalance HD2 Optimization

8.3.2 Input Clock Divider

An input clock divider allows a high frequency clock signal to be distributed throughout the system and locally divided down at the ADC device so that coupling of signals at common intermediate frequencies into other parts of the system can be avoided. The frequency at the CLKIN input may be divided down to the sampling rate of the ADC by factors of 1, 2, 4, or 8. Changing the clock divider setting initiates a JESD204 link re-initialization and requires re-calibration of the ADC if the sampling rate is changed from the rate during the previous calibration.

8.3.3 SYSREF Offset Feature and Detection Gate

When the signal at the SYSREF input is not actively toggling periodically, the SYSREF signal is considered to be in an idle state. The idle state is recommended at any time the ADC14X250 spurious performance must be maximized. When the SYSREF signal is in the idle state for longer than 1 μ s, an undesirable offset voltage may build up across the AC coupling capacitors between the SYSREF transmitter and the ADC14X250 device input. This offset voltage creates a signal threshold problem, requires a long time to dissipate, and therefore prevents quick transition of the SYSREF signal out of the idle state. Two features are provided as a solution and are shown in [Figure 50](#), namely the SYSREF offset feature and SYSREF detection gate.

Feature Description (continued)

In the case that the SYSREF signal idle state has a 0-V differential value, or if the ADC14X250 device must be insensitive to noise that may appear on the SYSREF signal, then the SYSREF detection gate may be used. The detection gate is the AND gate shown in Figure 50 that enables or disables propagation of the SYSREF signal through to the internal device logic. If the detection gate is disabled and a false edge appears at the SYSREF input, the signal does not disrupt the internal clock alignment. Note that the SYSREF detection gate is disabled by default; therefore, the device does not respond to a SYSREF edge until the detection gate is enabled.

The SYSREF offset and detection gate features are both controlled through the SPI.

8.3.4 DC Offset Correction

DC offset correction is provided using a digital high-pass IIR filter at the immediate output of the ADC core. The DC offset correction is bypassed by default, but may be enabled and configured via the SPI. The 3-dB bandwidth of the IIR digital correction filter may be set to four different low-frequency values. When DC offset correction is enabled, any signal in the stop-band of the high-pass filter is attenuated. The settling time of the DC offset correction is approximately equal to the inverse of the 3-dB bandwidth setting.

8.3.5 Serial Differential Output Drivers

The differential drivers of the ADC14X250 device that output the serial JESD204B data are voltage mode drivers with amplitude control and de-emphasis features that may be configured through the SPI for a variety of different channel applications. Eight amplitude control (VOD) and eight de-emphasis control (DEM) settings are available. Both VOD and DEM register fields must be configured to optimize the noise performance of the serial interface for a particular lossy channel.

The output common-mode of the driver varies with the configuration of the output swing. Therefore, AC coupling is strongly recommended between the ADC14X250 device and the device receiving the serial data.

8.3.5.1 De-Emphasis Equalization

De-emphasis of the differential output is provided as a form of continuous-time linear equalization that imposes a high-pass frequency response onto the output signal to compensate for frequency-dependent attenuation as the signal propagates through the channel to the receiver. In the time-domain, the de-emphasis appears as the bit transition transient followed by an immediate reduction in the differential amplitude, as shown in Figure 34. The characteristic appearance of the waveform changes with differential amplitude and the magnitude of de-emphasis applied. The serial lane rate determines the available period of time during which the de-emphasis transient settles. However, the lane rate does not affect the settling behavior of the applied de-emphasis.

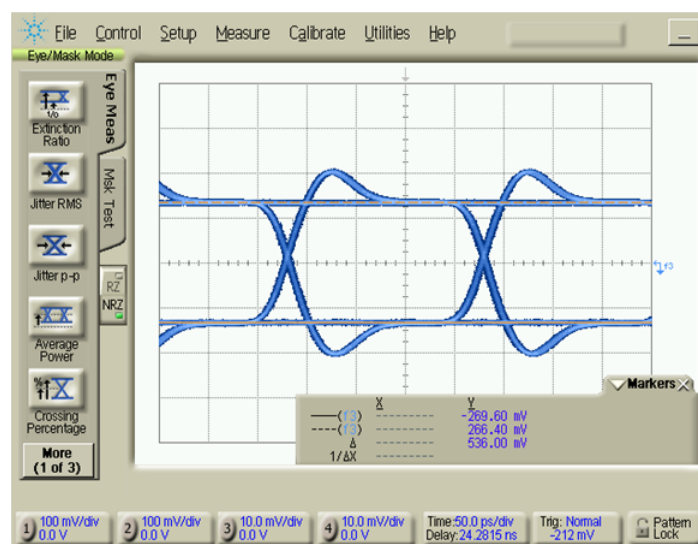

Figure 34. De-emphasis of the Differential Output Signal

Feature Description (continued)

Table 1 indicates the typical measured values for the de-emphasis range, where the de-emphasis value is measured as the ratio (in units of [dB]) between the peak voltage after the signal transition to the settled voltage value in one bit period. The data rate for this measurement is 1.2 Gb/s to allow settling of the de-emphasis transient. Table 1 illustrates the actual de-emphasis value in terms of voltage attenuation and shows dependence on the amplitude setting, but does not reflect the optimal amplitude setting (VOD) and de-emphasis setting (DEM) for a particular lossy channel. Table 2 shows the amplitude of the differential signal swing during its settled state after the transition transient. The measurement is performed at 1.2 Gb/s and the units are in differential peak-to-peak mV.

Table 1. De-Emphasis Values (dB) for All VOD and DEM Configuration Settings

		DEM							
		0	1	2	3	4	5	6	7
VOD	0	0	-0.2	-1.1	-2.2	-3.0	-4.3	-5.6	-8.5
	1	0	-0.4	-1.7	-2.9	-3.8	-5.1	-6.5	-9.6
	2	0	-0.7	-2.2	-3.5	-4.5	-5.9	-7.4	-10.4
	3	0	-1.0	-2.8	-4.2	-5.2	-6.7	-8.1	-11.2
	4	0	-1.4	-3.4	-4.9	-5.9	-7.4	-8.9	-12.1
	5	0	-1.7	-3.9	-5.5	-6.5	-8.0	-9.5	-12.7
	6	0	-2.1	-4.4	-6.0	-7.1	-8.6	-10.2	-13.4
	7	0	-2.5	-4.9	-6.5	-7.6	-9.2	-10.7	-14.0

Table 2. Settled Differential Voltage Swing Values, VOD (mV-peak-peak) for All VOD and DEM Configuration Settings

		DEM							
		0	1	2	3	4	5	6	7
VOD	0	570	550	500	440	400	350	300	210
	1	660	630	550	470	430	370	310	220
	2	750	690	580	500	450	380	320	230
	3	840	750	610	520	460	390	330	230
	4	940	800	630	530	470	400	340	230
	5	1020	840	650	550	480	410	340	240
	6	1110	870	670	560	490	410	340	240
	7	1200	900	680	570	500	420	350	240

8.3.6 ADC Core Calibration

After power-up, the ADC14X250 device detects that the supplies and clock are valid, waits for a power-up delay, and then performs a calibration of the ADC core automatically. The power-up delay is 8.4×10^6 sampling clock cycles or 33.6 ms at a 250-MSPS sampling rate. The calibration requires approximately 1.0×10^6 sampling clock cycles.

If the system requires that the ADC14X250 input clock divider value (CLKDIV) is set to 2, 4, or 8, then ADC calibration must be performed manually after CLKDIV has been set to the desired value. Manual calibration is performed by changing to power down mode, returning to normal operation, and monitoring the CAL_DONE bit in the JESD_STATUS register until calibration is complete. As an alternative to monitoring CAL_DONE, the system may wait 1.5×10^6 sampling clock cycles until calibration is complete.

Re-calibration is not required across the supported operating temperature range to maintain functional performance, but it is recommended for large changes in ambient temperature to maintain optimal dynamic performance. Changing the sampling rate always requires re-calibration of the ADC core. For more information about device modes, see [Power-Down and Sleep Modes](#).

8.3.7 Data Format

Data may be output in the serial stream as 2's complement format by default or optionally as offset binary. This formatting is configured through the SPI and is performed in the data path prior to JESD204B data framing, scrambling and 8b/10b encoding.

8.3.8 JESD204B Supported Features

The ADC14X250 device supports a feature set of the JESD204B standard targeted to its intended applications but does not implement all the flexibility of the standard. Table 3 summarizes the level of feature support.

Table 3. ADC14X250 Feature Support for the JESD204B Serial Interface

Feature	Supported	Not Supported
Subclass	<ul style="list-style-type: none"> Subclass 1 	<ul style="list-style-type: none"> Subclass 0⁽¹⁾, 2
Device Clock (CLKIN) and SYSREF	<ul style="list-style-type: none"> AC coupled CLKIN and SYSREF DC coupled CLKIN and SYSREF (special cases) Periodic, Pulsed Periodic and One-Shot SYSREF 	
Latency	<ul style="list-style-type: none"> Deterministic latency supported for subclass 1 implementations using standard SYSREF signal 	<ul style="list-style-type: none"> Deterministic latency not supported for non-standard implementations
Electrical layer features	<ul style="list-style-type: none"> LV-OIF-11G-SR interface and performance AC coupled serial lanes 	<ul style="list-style-type: none"> TX lane polarity inversion DC coupled serial lanes
Transport layer features and configuration	<ul style="list-style-type: none"> L = 1 K configuration Scrambling 	<ul style="list-style-type: none"> F, S, and HD configuration depends on L and is not independently configurable M, N, N', CS, CF configuration Idle link mode Short and Long transport layer test patterns
Data link layer features	<ul style="list-style-type: none"> 8b/10b encoding Lane synchronization D21.5, K28.5, ILA, PRBS7, PRBS15, PRBS23, Ramp test sequences 	<ul style="list-style-type: none"> RPAT/JSPAT test sequences

(1) The ADC14X250 supports most subclass 0 requirements, but is not strictly subclass compliant.

8.3.9 Transport Layer Configuration

The transport layer features supported by the ADC14X250 device are a subset of possible features described in the JESD204B standard. The configuration options are intentionally simplified to provide the lowest power and most easy-to-use solution.

8.3.9.1 Lane Configuration

The ADC14X250 outputs all digital data on a single JESD204B serial lane. The serial-data lane transmits at 20 times the sampling rate. A 250 MSPS sampling rate corresponds to a 5.0 Gb/s per lane rate.

8.3.9.2 Frame Format

The format of the data arranged in a frame is fixed. The octets per frame (F), samples per frame (S), and high-density mode (HD) parameters are not independently configurable. The N, N', CS, CF, M, and HD parameters are fixed and not configurable. Figure 35 shows the data format.

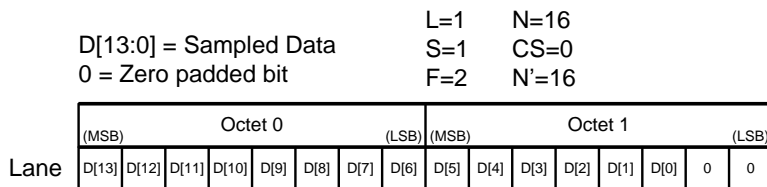

Figure 35. Transport Layer Definitions for the Supported-Lane Configurations

8.3.9.3 ILA Information

Table 4 summarizes the information transmitted during the initial lane alignment (ILA) sequence. Mapping of these parameters into the data stream is described in the JESD204B standard.

Table 4. Configuration of the JESD204B Serial-Data Receiver

Parameter	Description	Logical Value	Encoded Value
ADJCNT	DAC LMFC adjustment	0	0
ADJDIR	DAC LMFC adjustment direction	0	0
BID	Bank ID	0	0
CF	Number of control words per frame clock period per link	0	0
CS	Number of control bits per sample	0	0
DID	Device identification number	0	0
F	Number of octets per frame (per lane) ⁽¹⁾	2	1
HD	High-density format	0	0
JESDV	JESD204 version	1	1
K	Number of frames per multi-frame ⁽¹⁾	Set by register as 9 to 32	8 to 31
L	Number of lanes per link ⁽¹⁾	1	0
LID	Lane identification number	0	0
M	Number of converters per device ⁽¹⁾	1	1
N	Converter resolution ⁽¹⁾	16	15
N'	Total number of bits per sample ⁽¹⁾	16	15
PHADJ	Phase adjustment request to DAC	0	0
S	Number of samples per converter per frame cycle ⁽¹⁾	1	0
SCR	Scrambling enabled	Set by register as 0 (disabled) or 1	0 or 1
SUBCLASSV	Device subclass version	1	1
RES1	Reserved field 1	0	0
RES2	Reserved field 2	0	0
FCHK	Checksum		34 + (K-1) + SCR

(1) These parameters have a binary-value-minus-1 encoding applied before being mapped into the link configuration octets. For example, F = 1 is encoded as 0.

Scrambling of the output serial data is supported and conforms to the JESD204B standard. Scrambling is disabled by default, but may be enabled via the SPI. When scrambling is enabled, the ADC14X250 device supports the early synchronization option by the receiver during the ILA sequence, although the ILA sequence data is never scrambled.

8.3.10 Test Pattern Sequences

The SPI may enable the following test pattern sequences. Short- and long-transport layer, RPAT, and JSPAT sequences are not supported.

Table 5. Supported Test Pattern Sequences

Test Pattern	Description	Common Purpose
D21.5	Alternating 1 and 0 pattern (101010...)	Jitter or system debug
K28.5	Continuous K28.5 symbols	System debug
Repeated ILA	ILA repeats indefinitely	System debug
Ramp	After ILA, a sample ramp is transmitted with programmable step. The 16-bit output word fully spans both octets that compose a sample.	System debug and transport layer verification

Table 5. Supported Test Pattern Sequences (continued)

Test Pattern	Description	Common Purpose
PRBS	PRBS 7/15/23 Complies with ITU-T O.150 specification and is compatible with J-BERT equipment	Jitter and bit error rate testing

8.3.11 JESD204B Link Initialization

A JESD204B link is established via link initialization, which involves the following steps: frame alignment, code group synchronization, and initial lane synchronization. These steps are shown in Figure 36. Link initialization must occur between the transmitting device (ADC14X250) and receiving device before sampled data may be transmitted over the link. The link initialization steps described here are specifically for the ADC14X250 device, supporting JESD204B subclass 1.

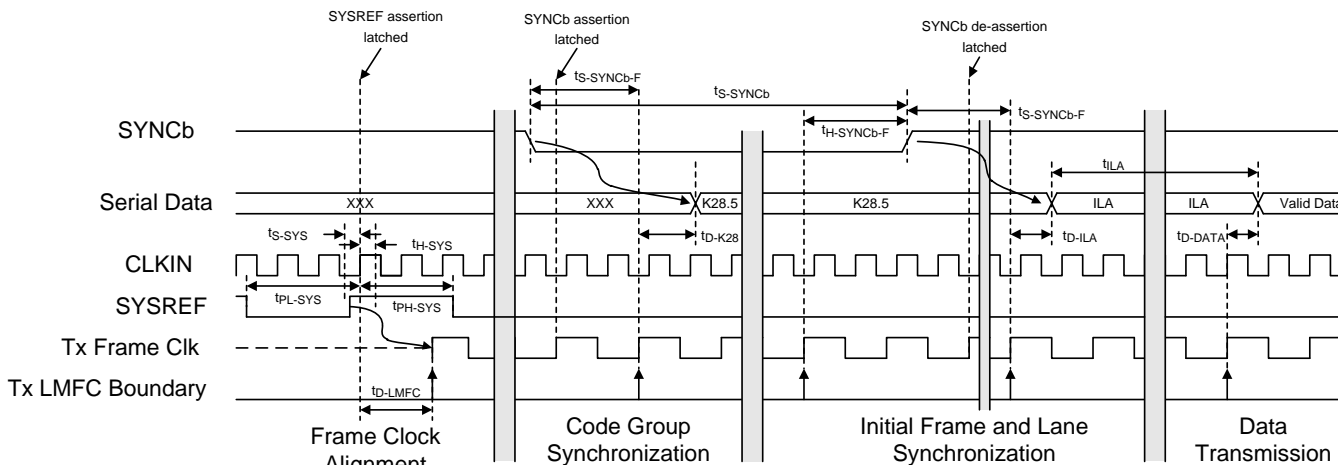

Figure 36. Link-initialization Timing and Flow Diagram

8.3.11.1 Frame Alignment

The Frame Alignment step requires alignment of the frame and local multi-frame clocks within the ADC14X250 device to an external reference. This is accomplished by providing the device clock and SYSREF clock to the CLKIN and SYSREF inputs, respectively. The ADC14X250 device aligns its frame clock and LMFC to any SYSREF rising edge event, offset by a SYSREF-to-LMFC propagation delay.

The SYSREF signal must be source synchronous to the device clock; therefore, the SYSREF rising edge must meet setup and hold requirements relative to the signal at the CLKIN input. If these requirements cannot be met, then the alignment of the internal frame and multi-frame clocks cannot be ensured. As a result, a link may still be established, but the latency through the link cannot be deterministic. Frame alignment may occur at any time; although, a re-alignment of the internal frame clock and LMFC will break the link. Note that frame alignment is not required for the ADC14X250 device to establish a link because the device automatically generates the clocks on power-up with unknown phase alignment.

8.3.11.2 Code Group Synchronization

Code Group Synchronization is initiated when the receiver sends a synchronization request by asserting the SYSCb input of the ADC14X250 device to a logic low state (SYSCb+ < SYSCb-). After the SYSCb assertion is detected, the ADC14X250 device outputs K28.5 symbols on all serial lanes that are used by the receiver to synchronize and time align its clock and data recovery (CDR) block to the known symbols. The SYSCb signal must be asserted for at least 4 frame clock cycles otherwise the event is ignored by the ADC14X250 device. Code group synchronization is completed when the receiver de-asserts the SYSCb signal to a logic high state.

After the ADC14X250 detects a de-assertion of its SYNCb input, the **Initial Lane Synchronization** step begins on the following LMFC boundary. The ADC14X250 device outputs 4 multi-frames of information that compose the ILA sequence. This sequence contains information about the data transmitted on the link. The initial lane synchronization step and link initialization conclude when the ILA is finished and immediately transitions into **Data Transmission**. During data transmission, valid sampled data is transmitted across the link until the link is broken.

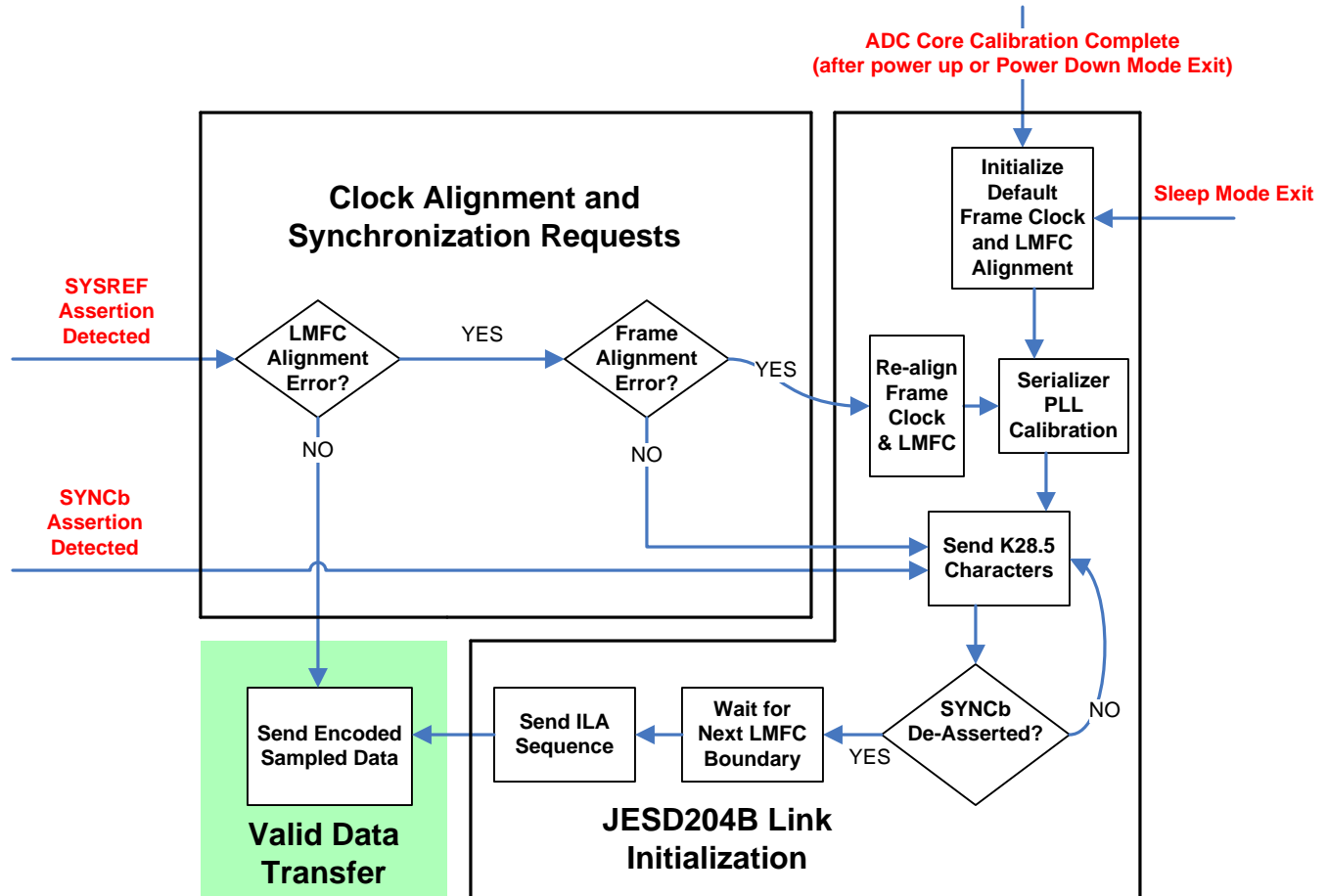

Figure 37. Device Start-Up and JESD204B Link Synchronization Flow Chart

The flowchart in [Figure 37](#) describes how the ADC14X250 device initializes the JESD204B link and reacts to changes in the link. After the ADC core calibration is finished, the ADC14X250 device begins with PLL calibration and link initialization using a default frame clock and LMFC alignment by sending K28.5 characters. PLL calibration requires approximately 153×10^3 sampling clock cycles. If SYNCb is not asserted, then the device immediately advances to the ILA sequence at the next LMFC boundary. Whereas, if SYNCb is asserted, then the device continues to output K28.5 characters until SYNCb is de-asserted.

When a SYSREF rising edge event is detected, then the ADC14X250 device compares the SYSREF event to the current alignment of the LMFC. If the SYSREF event is aligned to the current LMFC alignment, then no action is taken and the device continues to output data. If misalignment is detected, then the SYSREF event is compared to the frame clock. If misalignment of the frame clock is also detected, then the clocks are re-aligned and the link is re-initialized. If the frame clock is not misaligned, then the frame clock alignment is not updated. In the cases that a SYSREF event causes a link re-initialization, the ADC14X250 device begins sending K28.5 characters without a SYNCb assertion and immediately transitions to the ILA sequence on the next LMFC boundary unless the SYNCb signal is asserted. Anytime the frame clock and LMFC are re-aligned, the serializer PLL must calibrate before code group synchronization begins. SYSREF events must not occur during ADC14X250 device power-up, ADC calibration, or PLL calibration. The JESD_STATUS register is available to check the status of the ADC14X250 device and the JESD204B link.

If a SYNCb assertion is detected for at least 4 frame clock cycles, the ADC14X250 device immediately breaks the link and sends K28.5 characters until the SYNCb signal is de-asserted.

When exiting sleep mode, the frame clock and LMFC are started with a default (unknown) phase alignment, PLL calibration is performed, and the device immediately transitions into sending K28.5 characters.

8.3.12 Sync~ Signal Selection

The JESD204B sync~ signal can be directed to the internal JESD204B core block via two different input paths: via the external pins or SPI. The selection MUX is controlled using the SYNC_SEL register field and sync~ control is performed using the JSYNC_N register field via SPI. By default, the signal is routed from the external SYNCb+/- pins and writes to the JSYNC_N register field are ignored.

Optionally, the signal may be routed via SPI by setting the register field SYNC_SEL = 1. In this mode, signals at the external SYNCb+/- pins are ignored and the sync~ signal is written to the JSYNC_N register field.

8.3.13 SPI

The SPI allows access to the internal configuration registers of the ADC through read and write commands to a specific address. The interface protocol has a 1-bit command, 15-bit address word and 8-bit data word as shown in [Figure 38](#). A read or write command is 24 bits in total, starting with the read or write command bit where 0 indicates a write command and 1 indicates a read command. The read or write command bit is clocked into the device on the first rising edge of SCLK after CSb is asserted to 0. During a write command, the 15-bit address and 8-bit data values follow the read or write bit MSB-first and are latched on the rising edge of SCLK. During a read command, the SDO output is enabled shortly after the 16th rising edge of SCLK and outputs the read value MSB first before the SDO output is returned to a high impedance state. The read or write command is completed on the SCLK rising edge on which the data word's LSB is latched. CSb may be de-asserted to 1 after the LSB is latched into the device.

The SPI allows command streaming where multiple commands are made without de-asserting CSb in-between commands. The commands in the stream must be of similar types, either read or write. Each subsequent command applies to the register address adjacent to the register accessed in the previous command. The address order can be configured as either ascending or descending. Command streaming is accomplished by immediately following a completed command with another set of 8 rising edges of SCLK without de-asserting CSb. During a write command, an 8-bit data word is input on the SDI input for each subsequent set of SCLK edges. During a read command, data is output from SDO for each subsequent set of SCLK edges. Each subsequent command is considered finished after the 8th rising edge of SCLK. De-asserting CSb aborts an incomplete command.

The SDO output is high impedance at all times other than during the final portion of a read command. During the time that the SDO output is active, the logic level is determined by a configuration register. The SPI output logic level must be properly configured after power up and before making a read command to prevent damaging the receiving device or any other device connected to the SPI bus. Until the SPI_CFG register is properly configured, voltages on the SDO output may be as high as the V_{A3.0} supply during a read command. The default state of SDO is to output 3 V logic levels during a read command. The SDI, SCLK, and CSB pins are all 1.2-V to 3-V logic compatible.

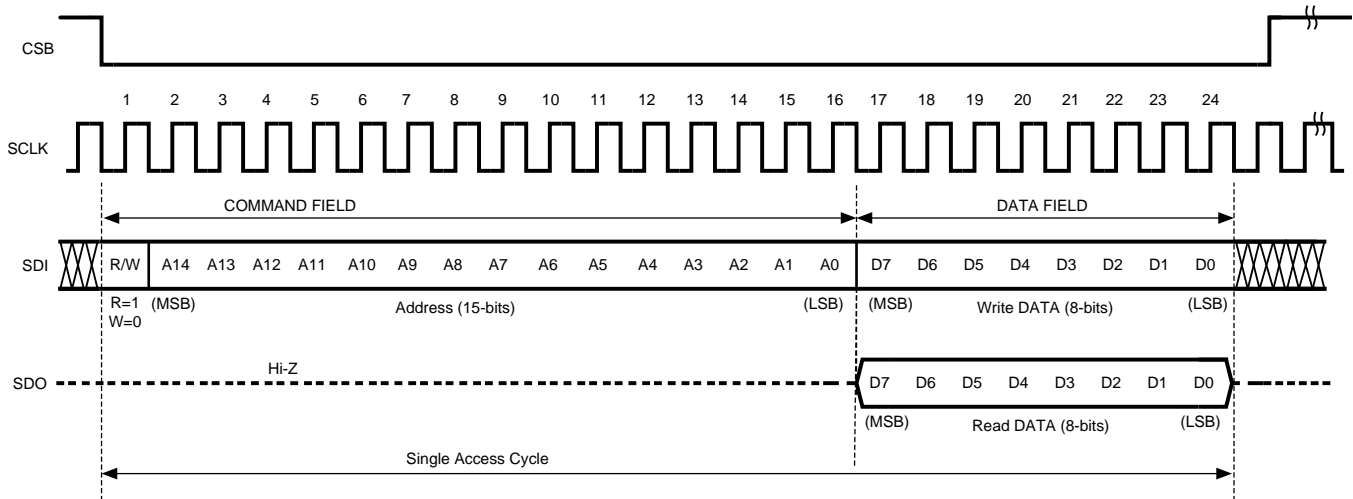
Figure 38. Serial Interface Protocol

8.4 Device Functional Modes

8.4.1 Power-Down and Sleep Modes

Power-down and sleep modes are provided to allow the user to reduce the power consumption of the device without disabling power supplies. Both modes reduce power consumption by the same amount but they differ in the amount of time required to return to normal operation. Upon changing from Power Down back to Normal operation, an ADC calibration routine is performed. Waking from sleep mode does not perform ADC calibration (see [ADC Core Calibration](#) for more details). Neither power-down mode nor sleep mode resets configuration registers.

8.5 Register Map

Table 6. ADC14X250 Register Map

Register	ADDRESS	DFLT	b[7]	b[6]	b[5]	b[4]	b[3]	b[2]	b[1]	b[0]	
CONFIG_A	0x0000	0x3C	SR	Res (0)	ASCEND	Res (1)	PAL[3:0]				
Address 0x0001 Reserved											
DEVICE_CONFIG	0x0002	0x00	Reserved (000000)						PD_MODE[1:0]		
CHIP_TYPE	0x0003	0x03	Reserved (0000)				CHIP_TYPE[3:0]				
CHIP_ID	0x0004	0x01	CHIP_ID[7:0]								
	0x0005	0x00	CHIP_ID[15:8]								
CHIP_VER	0x0006	0x00	CHIP_VER[7:0]								
Address 0x0007-0x000B Reserved											
VENDOR_ID	0x000C	0x51	VENDOR_ID[7:0]								
	0x000D	0x04	VENDOR_ID[15:8]								
SPI_CFG	0x0010	0x01	Reserved (000000)						VSPI[1:0]		
OM1	0x0012	0x81	DF	Res (00)		IDLE[1:0]		SYS_EN	Res(01)		
OM2	0x0013	0x20	Reserved (001)			CLKDIV		Res (0)	Res (0)	Res (0)	
IMB_ADJ	0x0014	0x00	Res (0)	AMPADJ[2:0]			PHADJ[3:0]				
Address 0x0015-0x003C Reserved											
DC_MODE	0x003D	0x00	Reserved (000000)						DC_TC	DC_EN	
Address 0x003E-0x0046 Reserved											
SER_CFG	0x0047	0x00	Res(0)	VOD[2:0]			Res (0)	DEM[2:0]			
Address 0x0048-0x005F Reserved											
JESD_CTRL1	0x0060	0x7D	SCR_EN	K_M1[4:0]				Res (0)	JESD_EN		
JESD_CTRL2	0x0061	0x00	SYNC_SEL	JSYNC_N	Reserved (00)		JESD_TEST_MODE[3:0]				
JESD_RSTEP	0x0062	0x01	JESD_RSTEP[7:0]								
	0x0063	0x00	JESD_RSTEP[15:8]								
Address 0x0064-0x006B Reserved											
JESD_STATUS	0x006C	N/A	Res (0)	LINK	SYNC	REALIGN	ALIGN	PLL_LOCK	CAL_DONE	CLK_RDY	
Address 0x006D- Reserved											

8.5.1 Register Descriptions

8.5.1.1 CONFIG_A, [Address: 0x0000], [Default: 0x3C]

Table 7. CONFIG_A, [Address: 0x0000], [Default: 0x3C]

Bit	Field	Type	Reset	Description
7	SR	Read or write	0	Setting this soft reset bit causes all registers to be reset to their default state. This bit is self-clearing.
6	Reserved	Read or write	0	Reserved and must be written with 0.
5	ASCEND	Read or write	1	Order of address change during streaming reads or writes. 0 : Address is decremented during streaming reads or writes. 1 : Address is incremented during streaming reads or writes (default).
4	Reserved	Read	1	Reserved and must be written with 1.
3:0	PAL[3:0]	Read or write	1100	Palindrome Bits are bit 3 = bit 4, bit 2 = bit 5, bit 1 = bit 6, and bit 0 = bit 7.

8.5.1.2 DEVICE CONFIG, [Address: 0x0002], [Default: 0x00]

Table 8. DEVICE CONFIG, [Address: 0x0002], [Default: 0x00]

Bit	Field	Type	Reset	Description
[7:2]	Reserved	Read or write	000000	Reserved and must be written with 000000.
[1:0]	PD_MODE [1:0]	Read or write	00	Power-down mode 00 : Normal operation (default) 01 : Reserved 10 : Sleep operation (faster resume) 11 : Power-down (slower resume)

8.5.1.3 CHIP_TYPE, [Address: 0x0003], [Default: 0x03]

Table 9. CHIP_TYPE, [Address: 0x0003], [Default: 0x03]

Bit	Field	Type	Reset	Description
[7:4]	Reserved	Read or write	0000	Reserved and must be written with 0000.
[3:0]	CHIP_TYPE	Read	0011	Chip type that always returns 0x3, indicating that the part is a high-speed ADC

8.5.1.4 CHIP_ID, [Address: 0x0005, 0x0004], [Default: 0x00, 0x01]

Table 10. CHIP_ID, [Address: 0x0005, 0x0004], [Default: 0x00, 0x01]

Bit	Field	Type	Reset	Description
0x0004[7:0]	CHIP_ID[7:0]	Read	0x01	Chip ID least significant word
0x0005[7:0]	CHIP_ID[15:8]	Read	0x00	Chip ID most significant word

8.5.1.5 CHIP_VERSION, [Address: 0x0006], [Default: 0x00]

Table 11. CHIP_VERSION, [Address: 0x0006], [Default: 0x00]

Bit	Field	Type	Reset	Description
[7:0]	CHIP_VER	Read	0x00	Chip version

8.5.1.6 VENDOR_ID, [Address: 0x000D, 0x000C], [Default: 0x04, 0x51]
Table 12. VENDOR_ID, [Address: 0x000D, 0x000C], [Default: 0x04, 0x51]

Bit	Field	Type	Reset	Description
0x000C[7:0]	VENDOR_ID [7:0]	Read	0x51	Vendor ID. Texas Instruments vendor ID is 0x0451.
0x000D[7:0]	VENDOR_ID [15:8]	Read	0x04	

8.5.1.7 SPI_CFG, [Address: 0x0010], [Default: 0x01]
Table 13. SPI_CFG, [Address: 0x0010], [Default: 0x01]

Bit	Field	Type	Reset	Description
[7:2]	Reserved	Read or write	000000	Reserved and must be written with 000000.
[1:0]	VSPI	Read or write	01	SPI logic level controls the SDO output logic level. 00 : 1.2 V 01 : 3.0 V (default) 10 : 2.5 V 11 : 1.8 V This register must be configured (written) before making a read command on the SPI bus if the logic level is different that the VSPI setting. The SPI inputs (SDI, SCLK, and CSb) are compatible with logic levels ranging from 1.2 to 3 V.

8.5.1.8 OM1 (Operational Mode 1), [Address: 0x0012], [Default: 0x81]
Table 14. OM1 (Operational Mode 1), [Address: 0x0012], [Default: 0x81]

Bit	Field	Type	Reset	Description
[7]	DF	Read or write	1	Output data format 0 : Offset binary 1 : Signed 2s complement (default)
[6:5]	Reserved	Read or write	00	Reserved and must be written with 00.
[4:3]	IDLE[1:0]	Read or write	00	SYSREF idle state offset configuration. 00 : No offset applied (default) 01 : SYSREF idles low (de-asserted) with –400-mV offset 10 : SYSREF idles high (asserted) with +400-mV offset 11 : Reserved
[2]	SYS_EN	Read or write	0	SYSREF detection gate enable 0 : SYSREF gate is disabled; (input is ignored, default) 1 : SYSREF gate is enabled
[1:0]	Reserved[1:0]	Read or write	01	Reserved. Must be written with 01.

8.5.1.9 OM2 (Operational Mode 2), [Address: 0x0013], [Default: 0x20]
Table 15. OM2 (Operational Mode 2), [Address: 0x0013], [Default: 0x20]

Bit	Field	Type	Reset	Description
[7:5]	Reserved	Read or write	001	Reserved and must be written with 001.
[4:3]	CLKDIV[1:0]	Read or write	00	Clock divider ratio. Sets the value of the clock divide factor, CLKDIV 00 : Divide by 1, CLKDIV = 1 (default) 01 : Divide by 2, CLKDIV = 2 10 : Divide by 4, CLKDIV = 4 11 : Divide by 8, CLKDIV = 8
[2:0]	Reserved	Read or write	000	Reserved. Must be written with 000.

8.5.1.10 IMB_ADJ (Imbalance Adjust), [Address: 0x0014], [Default: 0x00]
Table 16. IMB_ADJ (Imbalance Adjust), [Address: 0x0014], [Default: 0x00]

Bit	Field	Type	Reset	Description
[7]	Reserved	Read or write	0	Reserved. Must be written with 0.
[6:4]	AMPADJ[2:0]	Read or write	000	Analog input amplitude imbalance correction 7 = +30 Ω VIN+, -30 Ω VIN- 6 = +20 Ω VIN+, -20 Ω VIN- 5 = +10 Ω VIN+, -10 Ω VIN- 4 = Reserved 3 = -30 Ω VIN+, +30 Ω VIN- 2 = -20 Ω VIN+, +20 Ω VIN- 1 = -10 Ω VIN+, +10 Ω VIN- 0 = +0 Ω VIN+, -0 Ω VIN- (default) Resistance changes indicate variation of the internal single-ended termination.
[3:0]	PHADJ[3:0]	Read or write	0000	Analog input phase imbalance correction 15 = +1.68 pF VIN- ... 9 = +0.48 pF VIN- 8 = +0.24 pF VIN- 7 = +1.68 pF VIN+ ... 2 = +0.48 pF VIN+ 1 = +0.24 pF VIN+ 0 = +0 pF VIN+, +0 pF VIN- (default) Capacitance changes indicate the addition of internal capacitive load on the given pin.

8.5.1.11 DC_MODE (DC Offset Correction Mode), [Address: 0x003D], [Default: 0x00]
Table 17. DC_MODE (DC Offset Correction Mode), [Address: 0x003D], [Default: 0x00]

DC_MODE (DC Offset Correction Mode)							
Bit	Field	Type	Reset	Description			
[7:3]	Reserved	Read or write	00000	Reserved and must be written as 00000.			
[2:1]	TC_DC	Read or write	00	DC offset filter time constant. The time constant determines the filter bandwidth of the DC high-pass filter.			
				TC_DC	Time Constant (F _S = 250 MSPS)	3-dB Bandwidth (F _S = 250 MSPS)	3-dB Bandwidth (Normalized)
				00	17 μs	9.3 kHz	37e-6 × F _S
				01	130 μs	1.2 kHz	4.9e-6 × F _S
				10	1.1 ms	150 Hz	605e-9 × F _S
			11	8.4 ms	19 Hz	76e-9 × F _S	
[0]	DC_EN	Read or Write	0	DC offset correction enable 0 : Disable DC offset correction 1 : Enable DC offset correction			

8.5.1.12 SER_CFG (Serial Lane Transmitter Configuration), [Address: 0x0047], [Default: 0x00]
Table 18. SER_CFG (Serial Lane Transmitter Configuration), [Address: 0x0047], [Default: 0x00]

Bit	Field	Type	Reset	Description
[7]	Reserved	Read or write	0	Reserved. Must be written as 0.
[6:4]	VOD[2:0]	Read or write	000	Serial-lane transmitter driver output differential peak-peak-voltage amplitude. 000 : 0.570 V (default) 001 : 0.660 V 010 : 0.750 V 011 : 0.840 V 100 : 0.940 V 101 : 1.02 V 110 : 1.11 V 111 : 1.20 V Reported voltage values are nominal values at low-lane rates with de-emphasis disabled
[3]	Reserved	Read or write	0	Reserved and must be written as 0.
[2:0]	DEM[2:0]	Read or write	000	Serial lane transmitted de-emphasis. De-emphasis value are for VOD configured to 100.
	DEM			De-emphasis [dB]
	000			0.0
	001			1.4
	010			3.4
	011			4.9
	100			5.9
	101			7.4
	110			8.9
	111			12.1

8.5.1.13 JESD_CTRL1 (JESD Configuration Control 1) , [Address: 0x0060], [Default: 0x7D]
Table 19. JESD_CTRL1 (JESD Configuration Control 1) , [Address: 0x0060], [Default: 0x7D]

Note: Before altering any parameters in this register, one must set JESD_EN = 0. Changing parameters while JESD_EN = 1 is not supported.

Bit	Field	Type	Reset	Description
[7]	SCR_EN	Read or write	0	Scrambler enable. 0 : Disabled (default) 1 : Enabled Note: • JESD_EN must be set to 0 before altering this field.
[6:2]	K_M1[4:0]	Read or write	11111	Number of frames per multi-frame, K – 1. The binary values of K_M1 represent the value (K – 1) 00000 : Reserved 00001 : Reserved ... 00111 : Reserved 01000 : K = 9 ... 11111 : K = 32 (default) Note: • K must be in the range 9 to 32. Values outside this range are either reserved or may produce unexpected results. • JESD_EN must be set to 0 before altering this field.
[1]	Reserved	Read or write	0	Reserved and must be written as 0.
[0]	JESD_EN	Read or write	1	JESD204B link enable. When enabled, the JESD204B link synchronizes and transfers data normally. When the link is disabled, the serial transmitters output a repeating, alternating 01010101 stream. 0 : Disabled 1 : Enabled (default)

8.5.1.14 JESD_CTRL2 (JESD Configuration Control 2), [Address: 0x0061], [Default: 0x00]
Table 20. JESD_CTRL2 (JESD Configuration Control 2), [Address: 0x0061], [Default: 0x00]

Note: Before altering any parameters in this register, one must set JESD_EN = 0. Changing parameters while JESD_EN = 1 is not supported.				
Bit	Field	Type	Reset	Description
[7]	SYNC_SEL	Read or write	0	SYNCb Signal MUX Select 0 : The internal SYNCb signal is routed from the SYNCb+/- pins (default) 1 : The internal SYNCb signal is routed from the JSYNC_N register field (SYNCb over SPI)
[6]	JSYNC_N	Read or write	0	SYNCb Over SPI Control 0 : The internal SYNCb signal as asserted, indicating a JESD204 link synchronization request (default) 1 : The internal SYNCb signal is de-asserted, indicating JESD204 link synchronization is not being requested Note: JSYNC_N controls the internal SYNCb signal only when SYNC_SEL = 1. When SYNC_SEL = 0, this register field is ignored.
[7:4]	Reserved	Read or write	00	Reserved. Must be written as 00.
[3:0]	JESD_TEST_MODES[3:0]	Read or write	0000	JESD204B test modes. 0000 : Test mode disabled. Normal operation (default) 0001 : PRBS7 test mode 0010 : PRBS15 test mode 0011 : PRBS23 test mode 0100 : RESERVED 0101 : ILA test mode 0110 : Ramp test mode 0111 : K28.5 test mode 1000 : D21.5 test mode 1001: Logic low test mode (serial outputs held low) 1010: Logic high test mode (serial outputs held high) 1011 – 1111 : Reserved Note: • JESD_EN must be set to 0 before altering this field.

8.5.1.15 JESD_RSTEP (JESD Ramp Pattern Step), [Addresses: 0x0063, 0x0062], [Default: 0x00, 0x01]
Table 21. JESD_RSTEP (JESD Ramp Pattern Step), [Addresses: 0x0063, 0x0062], [Default: 0x00, 0x01]

Bit	Field	Type	Reset	Description
0x0062[7:0]	JESD_RSTEP [7:0]	Read or write	0x01	JESD204B ramp test mode step
0x0063[7:0]	JESD_RSTEP [15:8]	Read or write	0x00	The binary value JESD_RSTEP[15:0] corresponds to the step of the ramp mode step. A value of 0x0000 is not allowed. Note: • JESD_EN must be set to 0 before altering this field.

8.5.1.16 JESD_STATUS (JESD Link Status), [Address: 0x006C], [Default: N/A]
Table 22. JESD_STATUS (JESD Link Status), [Address: 0x006C], [Default: N/A]

Bit	Field	Type	Reset	Description
[7]	Reserved	Read	N/A	Reserved.
[6]	LINK	Read	N/A	JESD204B link status This bit is set when synchronization is finished, transmission of the ILA sequence is complete, and valid data is being transmitted. 0 : Link not established 1 : Link established and valid data transmitted

Table 22. JESD_STATUS (JESD Link Status), [Address: 0x006C], [Default: N/A] (continued)

Bit	Field	Type	Reset	Description
[5]	SYNC	Read	N/A	<p>JESD204B link synchronization request status</p> <p>This bit is cleared when a synchronization request is received at the SYNCb input.</p> <p>0 : Synchronization request received at the SYNCb input and synchronization is in progress</p> <p>1 : Synchronization not requested</p> <p>Note:</p> <ul style="list-style-type: none"> • SYNCb must be asserted for at least four local frame clocks before synchronization is initiated. The SYNC status bit reports the status of synchronization, but does not necessarily report the current status of the signal at the SYNCb input.
[4]	REALIGN	Read or write	N/A	<p>SYSREF re-alignment status</p> <p>This bit is set when a SYSREF event causes a shift in the phase of the internal frame or LMFC clocks.</p> <p>Note:</p> <ul style="list-style-type: none"> • Write a 1 to REALIGN to clear the bit field to a 0 state. • SYSREF events that do not cause a frame or LMFC clock phase adjustment do not set this register bit. • If CLK_RDY becomes low, this bit is cleared.
[3]	ALIGN	Read or write	N/A	<p>SYSREF alignment status</p> <p>This bit is set when the ADC has processed a SYSREF event and indicates that the local frame and multi-frame clocks are now based on a SYSREF event.</p> <p>Note:</p> <ul style="list-style-type: none"> • Write a 1 to ALIGN to clear the bit field to a 0 state. • Rising-edge SYSREF event sets ALIGN bit. • If CLK_RDY becomes low, this bit is cleared.
[2]	PLL_LOCK	Read	N/A	<p>PLL lock status. This bit is set when the PLL has achieved lock.</p> <p>0 : PLL unlocked</p> <p>1 : PLL locked</p>
[1]	CAL_DONE	Read	N/A	<p>ADC calibration status</p> <p>This bit is set when the ADC calibration is complete.</p> <p>0 : Calibration currently in progress or not yet completed</p> <p>1 : Calibration complete</p> <p>Note:</p> <ul style="list-style-type: none"> • Calibration must complete before SYSREF detection (SYS_EN) can be enabled. • Calibration must complete before the any clock phase delay adjustments are made.
[0]	CLK_RDY	Read	N/A	<p>Input clock status</p> <p>This bit is set when the ADC is powered-up and detects an active clock signal at the CLKIN input.</p> <p>0 : CLKIN not detected</p> <p>1 : CLKIN detected</p>

9 Application and Implementation

NOTE

Information in the following applications sections is not part of the TI component specification, and TI does not warrant its accuracy or completeness. TI's customers are responsible for determining suitability of components for their purposes. Customers should validate and test their design implementation to confirm system functionality.

9.1 Application Information

9.1.1 Analog Input Considerations

9.1.1.1 Differential Analog Inputs and Full Scale Range

The ADC14X250 device has a single channel with a pair of analog signal input pins: VIN+, VIN-. VIN, the input differential signal for a channel, is defined as $VIN = (VIN+) - (VIN-)$. Table 23 shows the expected input signal range when the differential signal swings about the input common mode, VCM. The full-scale differential peak-to-peak input range is equal to twice the internal reference voltage, VREF. Nominally, the full scale range is 1.7 Vpp-diff, therefore the maximum peak-to-peak single-ended voltage is 0.85 Vpp at each of the VIN+ and VIN- pins.

The single-ended signals must be opposite in polarity relative to the VCM voltage to provide a purely differential signal, otherwise the common-mode component may be rejected by the ADC input. Table 23 indicates the input to output relationship of the ADC14X250 device where $V_{REF} = 0.85\text{ V}$. Differential signals with amplitude or phase imbalances result in lower system performance compared to perfectly balanced signals. Imbalances in signal path circuits lead to differential-to-common-mode signal conversion and differential signal amplitude loss as shown in Figure 39. This deviation or imbalance directly causes a reduction in the signal amplitude and may also lead to distortion, particularly even order harmonic distortion, as the signal propagates through the signal path. The differential imbalance correction feature of the ADC14X250 device helps to correct amplitude or phase errors in the signal.

Table 23. Mapping of the Analog Input Full Scale Range to Digital Codes

VIN+	VIN-	2s Complement Output	Binary Output	Note
$V_{CM} - V_{REF} / 2$	$V_{CM} + V_{REF} / 2$	10 0000 0000 0000	00 0000 0000 0000	Negative full-scale
$V_{CM} - V_{REF} / 4$	$V_{CM} + V_{REF} / 4$	11 0000 0000 0000	01 0000 0000 0000	
V_{CM}	V_{CM}	00 0000 0000 0000	10 0000 0000 0000	Mid-scale
$V_{CM} + V_{REF} / 4$	$V_{CM} - V_{REF} / 4$	01 0000 0000 0000	11 0000 0000 0000	
$V_{CM} + V_{REF} / 2$	$V_{CM} - V_{REF} / 2$	01 1111 1111 1111	11 1111 1111 1111	Positive full-scale

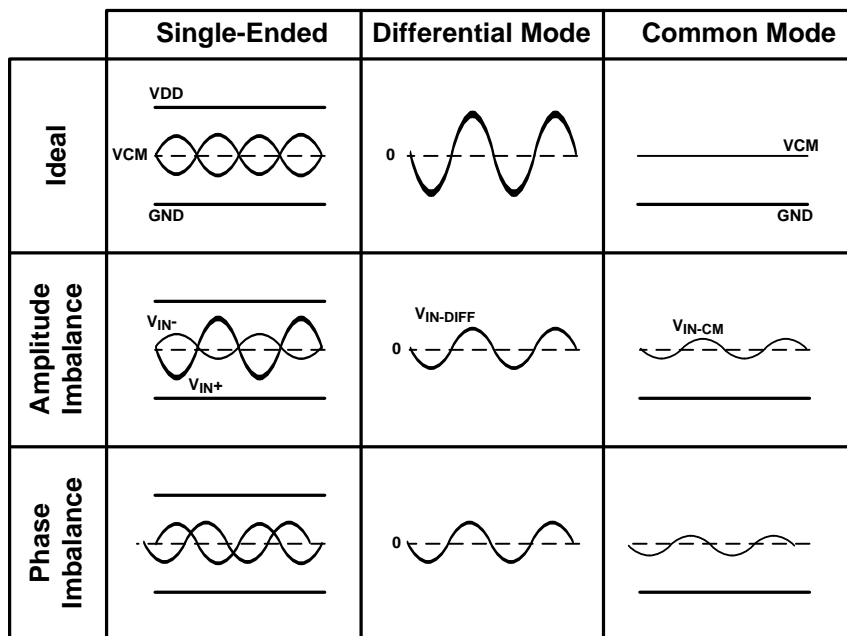

Figure 39. Differential Signal Waveform and Signal Imbalance

9.1.1.2 Analog Input Network Model

Matching the impedance of the driving circuit to the input impedance of the ADC can be important for low distortion performance and a flat gain response through the network across frequency. In very broadband applications or lowpass applications, the ADC driving network must have very low impedance with a small termination resistor at the ADC input to maximize the bandwidth and minimize the bandwidth limitation posed by the capacitive load of the ADC input. In bandpass applications, a designer may either design the anti-aliasing filter to match to the complex impedance of the ADC input at the desired intermediate frequency, or consider the resistive part of the ADC input to be part of the resistive termination of the filter and the capacitive part of the ADC input to be part of the filter itself.

The analog input circuit of the ADC14X250 device is a buffered input with an internal differential termination. Compared to an ADC with a switched-capacitor input sampling network that has an input impedance that varies with time, the ADC14X250 device provides a constant input impedance that simplifies the interface design joining the ADC and ADC driver. A simplified passive model of the ADC input network is shown in Figure 40 that includes the termination resistance, input capacitance, parasitic bond-wire inductance, and routing parasitics.

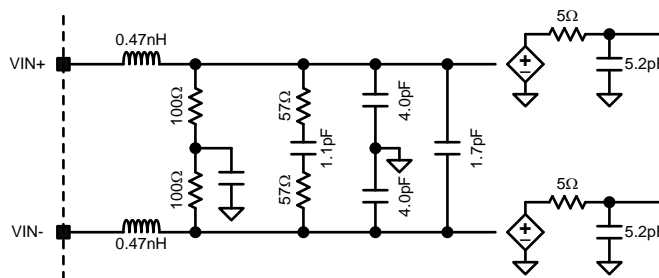

Figure 40. Simplified Analog Input Network Circuit Model

A more accurate load model is described by the measured differential SDD11 (100-Ω) parameter model. A plot of the differential impedance derived from the model is shown on the Smith chart of Figure 41. The model includes the internal 200-Ω resistive termination, the capacitive loading of the input buffer, and stray parasitic impedances like bond wire inductance and signal routing coupling. The SDD11 model may be used to back-calculate the impedance of the ADC input at a frequency of interest.

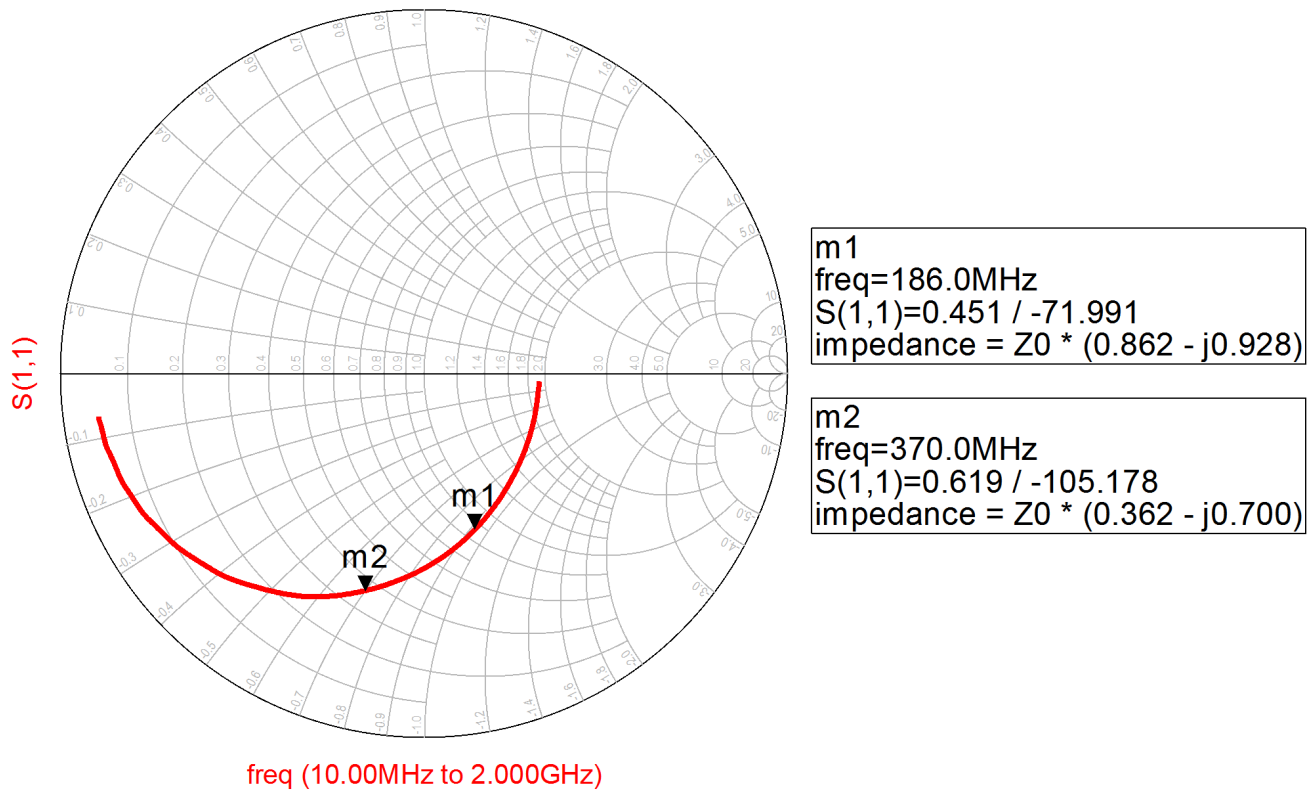

Figure 41. Measured Differential Impedance of Analog Input Network on a Smith Chart (100 Ω)

9.1.1.3 Input Bandwidth

The input bandwidth of the ADC14X250 device is defined here as the frequency at which the fundamental amplitude of the sampled data deviates by 3 dB, compared to the amplitude at low frequencies, for a low-impedance input sinusoidal signal with constant voltage amplitude at the VIN+ and VIN– input pins. The voltage frequency response is shown in Figure 42.

The peaking in the frequency response is caused by the resonance between the package bond wires and input capacitance as well as a parasitic 0.5-nH series trace inductance leading to the device pins. This peaking is typically made insignificant by the stop-band of an anti-aliasing filter that precedes the ADC input. For broadband applications, 10-Ω resistors may be put in series with the VIN+ and VIN– input pins. This extra resistance flattens out the frequency response at the cost of adding some attenuation in the signal path. The additional series resistance also accordingly modifies the measured SDD11 looking into the analog input.

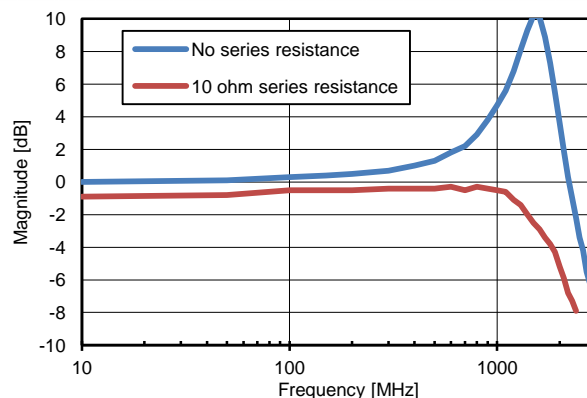

Figure 42. Measured Input Voltage Frequency Response

9.1.1.4 Driving the Analog Input

The ADC14X250 device analog input may be driven by a number of methods depending on the end application. The most important design aspects to consider when designing the ADC voltage driver network are signal coupling, impedance matching, differential signal balance, anti-alias filtering, and signal level.

An analog signal is AC or DC coupled to the ADC depending on whether signal frequencies near DC must be sampled. DC coupling requires tight control of the output common-mode of the ADC driver to match the input common-mode of the ADC input. In the case of DC coupling, the bias at pin VCM may be used as a reference to establish the driver output common-mode, but the load cannot source or sink more current than what is specified in the electrical parameters. AC coupling does not require strict common-mode control of the driver and is typically achieved using AC coupling capacitors or a flux-coupled transformer. AC coupling capacitors should be chosen to have 0.1- Ω impedance or less over the frequency band of interest. LC filter designs may be customized to achieve either AC or DC coupling.

The internal input network of the ADC14X250 device has the common-mode voltage bias provided through internal shunt termination resistors, as shown in the CLKIN+/- pin description figure. TI also recommends providing the common-mode reference externally from the VCM pin, through external termination resistors.

Impedance matching in high speed signal paths using an ADC is dictated by the characteristic impedance of interconnects and by the design of anti-aliasing filters. Matching the source to the load termination is critical to ensure maximum power transfer to the load and to maintain gain flatness across the desired frequency band. In applications with signal transmission lengths greater than 10% of the smallest signal wavelength (0.1λ), matching is also desirable to avoid signal reflections and other transmission line effects. Applications that require high order anti-aliasing filter designs, including LC bandpass filters, require an expected source and load termination to ensure the passband bandwidth and ripple of the filter design. The recommended range of the total ADC load termination is from 50- to 200- Ω differential. The ADC14X250 device has an internal differential load termination, but additional termination resistance may be added at the ADC input pins to adjust the total termination. The load termination at the ADC input presents a system-level design tradeoff. Better 2nd order distortion performance (HD2, IMD2) is achieved by the ADC using a lower load termination resistance, but the ADC driver must have a higher drive strength and linearity to drive the lower impedance. Choosing a 100- Ω total load termination is a reasonable balance between these opposing requirements.

Differential signal balance is important to achieve good distortion performance, particularly even order distortion (HD2, HD4). Circuits such as transformers and filters in the signal path between the signal source and ADC can disrupt the amplitude and phase balance of the differential signal before reaching the ADC input due to component tolerances or parasitic mismatches between the two parallel paths of the differential signal. The amplitude mismatch in the differential path should be less than ± 0.4 dB and the phase mismatch should be less than $\pm 2^\circ$ to achieve a high level of HD2 performance. In the case that this imbalance is exceeded, the input balance correction may be used to re-balance the signal and improve the performance. Driving the ADC14X250 device with a single-ended signal is not supported due to the tight restriction on the ADC input common-mode to maintain good distortion performance.

Converting a single-ended signal to a differential signal may be performed by an ADC driver or transformer. The advantages of the ADC driver over a transformer include configurable gain, isolation from previous stages of analog signal processing, and superior differential signal balancing. The advantages of using a transformer include no additional power consumption and little additional noise or distortion.

Figure 43 is an example of driving the ADC input with a cascaded transformer configuration. The cascaded transformer configuration provides a high degree of differential signal balancing, the series 0.1- μ F capacitors provide AC coupling, and the additional 33- Ω termination resistors provide a total differential load termination of 50 Ω . When additional termination resistors are added to change the ADC load termination, shunt terminations to the VCM reference are recommended to reduce common-mode fluctuations or sources of common-mode interference. A differential termination may be used if these sources of common-mode interference are minimal. In either case, the additional termination components must be placed as close to the ADC pins as possible. The MABA007159 transmission-line transformer from this example is widely available and results in good differential balance. Shunt capacitors at the ADC input, used to suppress the charge kickback of an ADC with switched-capacitor inputs, are not required for this purpose because the buffered input of the ADC14X250 device does not kickback a significant amount of charge.

The insertion loss between an ADC driver and the ADC input is important because the driver must overcome the insertion loss of the connecting network to drive the ADC to full-scale and achieve the best SNR. Minimizing the loss through the network reduces the output swing and distortion requirements of the driver and usually translates to a system-level power savings in the driver. This can be accomplished by selecting transformers or filter designs with low insertion loss. Some filter designs may employ reduced source terminations or impedance conversions to minimize loss. Many designs require the use of high-Q inductors and capacitors to achieve an expected passband flatness and profile.

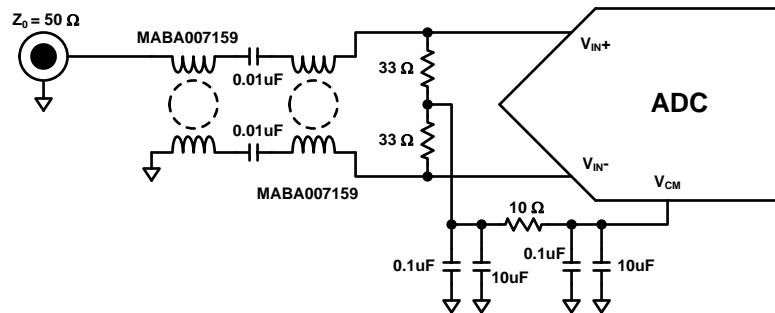

Figure 43. Transformer Input Network

Sampling theory states that if a signal with frequency f_{IN} is sampled at a rate less than $2 \times f_{IN}$, then it experiences aliasing, causing the signal to fall at a new frequency between 0 and $F_S / 2$ and become indistinguishable from other signals at that new frequency.

To prevent out-of-band interference from aliasing onto a desired signal at a particular frequency, an anti-aliasing filter is required at the ADC input to attenuate the interference to a level below the level of the desired signal. This is accomplished by a lowpass filter in systems with desired signals from DC to $F_S / 2$ or with a bandpass filter in systems with desired signals greater than $F_S / 2$ (under-sampled signals). If an appropriate anti-aliasing filter is not included in the system design, the system may suffer from reduced dynamic range due to additional noise and distortion that aliases into the frequency bandwidth of interest.

An anti-aliasing filter is required in front of the ADC input in most applications to attenuate noise and distortion at frequencies that alias into any important frequency band of interest during the sampling process. An anti-aliasing filter is typically a LC lowpass or bandpass filter with low insertion loss. The bandwidth of the filter is typically designed to be less than $F_S / 2$ to allow room for the filter transition band. [Figure 44](#) is an example architecture of a 9 pole order LC bandpass anti-aliasing filter with added transmission zeros that can achieve a tight filtering profile for second Nyquist zone under-sampling applications.

Maximizing the distortion performance of this device requires the avoidance of driving circuits that are mostly capacitive at frequencies near and above the sampling rate. The performance is maximized by ensuring the driving circuit is high impedance or mostly resistive (real impedance) at these out-of-band frequencies. Driving circuits with highly capacitive source impedances (negative source reactance) at these frequencies can cause resonance with the interface, leading to sub-optimal distortion performance. In the case of bandpass LC anti-aliasing filters, the impedance looking into the filter output is recommended to be high impedance or real at frequencies near and above the sampling rate such as the filter shown in [Figure 42](#). Capacitors placed directly at the ADC input used as bandwidth limiters or as part of a filter's final stage LC tank are not recommended.

Applications that use lumped reactive components (capacitors, inductors) in the interface to the ADC are recommended to have a small series resistor at the ADC input, also shown in [Figure 42](#). Place these resistors close to the device pins, between the external termination resistors and the device pins. A value of 5Ω is sufficient for most applications, though TI recommends 10Ω for applications where the lumped differential capacitance at the ADC input is unavoidable and greater than 2 pF .

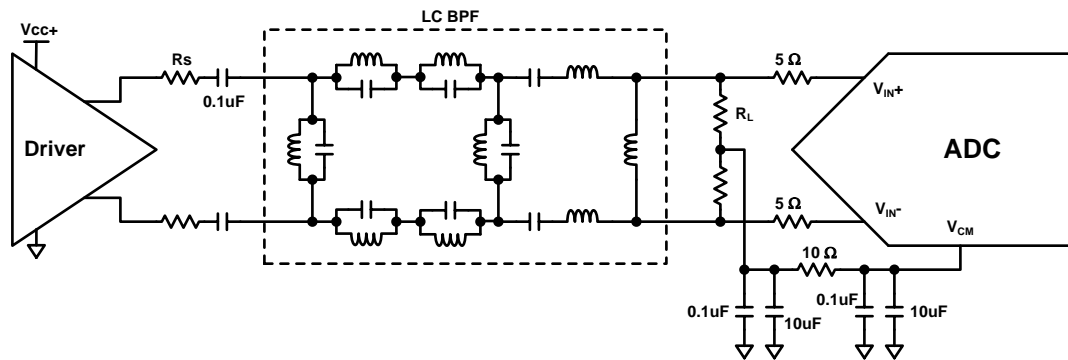

Figure 44. Bandpass Filter Anti-Aliasing Interface

DC coupling to the analog input is also possible but the input common-mode must be tightly controlled for specified performance. The driver device must have an output common-mode that matches the input common-mode of the ADC14X250 device and the driver must track the VCM output from the ADC14X250 device, as shown in the example DC coupled interface of Figure 45 because the input common-mode varies with temperature. The common-mode path from the VCM output, through the driver device, back to the ADC14X250 device input, and through a common-mode detector inside the ADC14X250 device forms a closed tracking loop that will correct common-mode offset contributed by the driver device but the loop must be stable to ensure correct performance. The loop requires the large, 10- μ F capacitor at the VCM output to establish the dominant pole for stability and the driver device must reliably track the VCM output voltage bias. The current drive strength and voltage swing of the VCM output bias limits the correctable amount of common-mode offset.

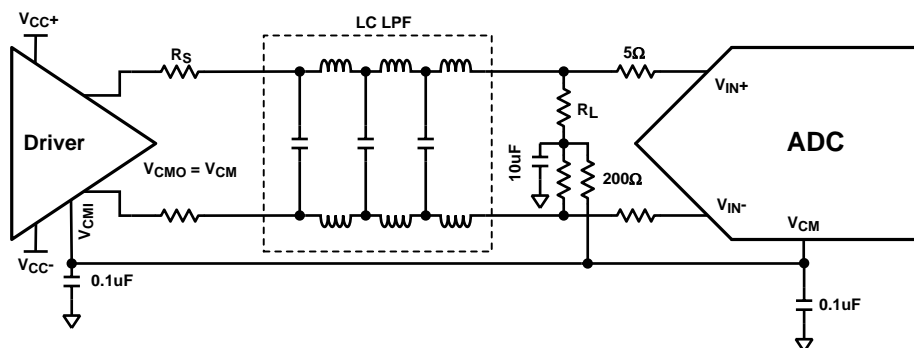

Figure 45. DC Coupled Interface

9.1.1.5 Clipping

The ADC14X250 device has two regions of signal clipping: code clipping (over-range) and ESD clipping. When the input signal amplitude exceeds the full-scale reference range, code clipping occurs during which the digital output codes saturate. If the signal amplitude increases beyond the absolute maximum rating of the analog inputs, ESD clipping occurs due to the activation of ESD diodes.

TI does not recommend ESD clipping and activation of the ESD diodes at the analog input, which may damage or shorten the life of the device. This clipping may be avoided by selecting an ADC driver with an appropriate saturating output voltage, by placing insertion loss between the driver and ADC, by limiting the maximum amplitude earlier in the signal path at the system level, or by using a dedicated differential signal limiting device such as back-to-back diodes. Any signal swing limiting device must be chosen carefully to prevent added distortion to the signal.

9.1.2 CLKIN, SYSREF, and SYNCb Input Considerations

Clocking the ADC14X250 device shares many common concepts and system design requirements with previously released ADC products, but the JESD204B supported architecture adds another layer of complexity to clocking at the system level. A SYSREF signal accompanies the device clock to provide phase alignment information for the output data serializer (as well as for the sampling instant when the clock divider is enabled) to ensure that the latency through the JESD204B link is always known and does not vary, a concept called deterministic latency. To ensure deterministic latency, the SYSREF signal must meet setup and hold requirements relative to CLKIN and the design of the clocking interfaces require close attention. As with other ADCs, the quality of the clock signal also influences the noise and spurious performance of the device.

9.1.2.1 Driving the CLKIN+ and CLKIN– Input

The CLKIN input circuit is composed of a differential receiver and an internal 100-Ω termination to a weakly driven common-mode of 0.50 V. TI recommends AC coupling to the CLKIN input with 0.1-μF external capacitors to maintain the optimal common-mode biasing. Figure 46 shows the CLKIN receiver circuit and an example AC coupled interface.

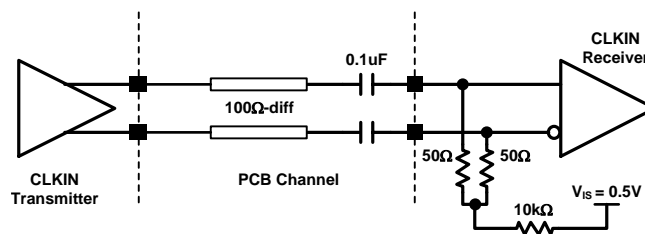

Figure 46. Driving the CLKIN Input With an AC Coupled Interface

DC coupling is allowed as long as the input common-mode range requirements are satisfied. The input common-mode of the CLKIN input is not compatible with many common signaling standards like LVDS and LVPECL. Therefore, the CLKIN signal driver common-mode must be customized at the transmitter or adjusted along the interface. Figure 47 shows an example DC coupled interface that uses a resistor divider network to reduce the common-mode while maintaining a 100-Ω total termination at the load. Design equations are provided with example values to determine the resistor values.

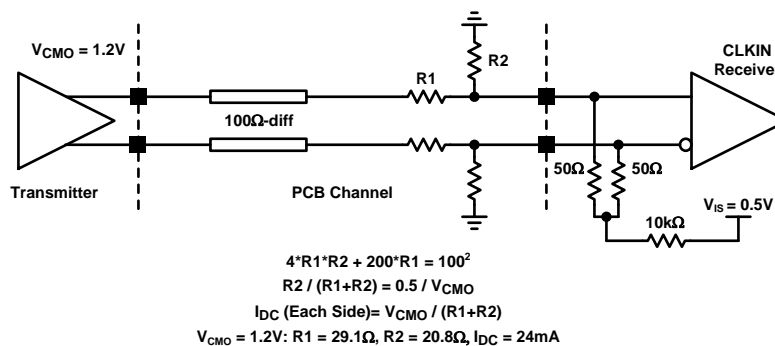

Figure 47. Driving the CLKIN Input With an Example DC Coupled Interface

The CLKIN input supports any type of standard signaling that meets the input signal swing and common-mode range requirements with an appropriate interface. Generic differential sinusoidal or square-wave clock signals are also supported. TI does not recommend driving the CLKIN input single-ended. The differential lane trace on the PCB should be designed to be a controlled 100 Ω and protected from noise sources or other signals.

9.1.2.2 Clock Noise and Edge Rate

Noise added to the sampling clock path of the ADC degrades the SNR performance of the system. This noise may include broadband noise added by the ADC clock receiver inside the ADC device but may also include broadband and in-close phase noise added by the clock generator and any other devices leading to the CLKIN input. The theoretical SNR performance limit of the ADC14X250 device as a result of clock noise for a given input frequency is shown in Figure 48 for a full scale input signal and different values of total jitter.

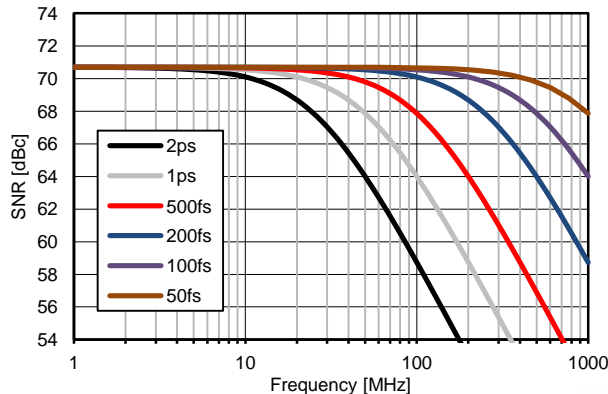

Figure 48. SNR Limit Due to Jitter of Sampling Clock With a Full-Scale Input Signal

The differential clock receiver of the ADC14X250 device has a very-low noise floor and wide bandwidth. The wide band clock noise of the receiver, also referred to as the additive jitter, modulates the sampling instant and adds the noise to the signal. At the sampling instant, the added broadband noise appears in the first Nyquist zone at the ADC output to degrade the noise performance. Minimizing the additive jitter requires a sampling clock with a steep edge rate at the zero crossing. Reduced edge rate increases the additive jitter. For clock signals with a differential swing of 100 mV or greater, the additive clock Figure 49 shows the SNR performance of the ADC14X250 device for a range of clock transition slopes.

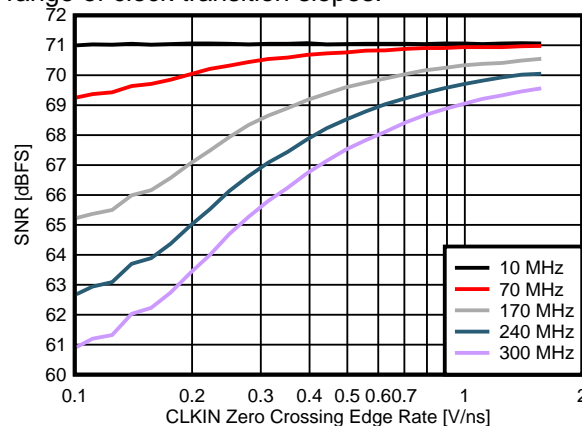

Figure 49. SNR vs Input Clock Edge Rate (-3 dBFS Input)

Noise added to the sampling clock by devices leading up to the ADC clock input also directly affects the noise performance of the system. In-close phase noise is typically dominated by the performance of the clock reference and phase-locked loop (PLL) that generates the clock and limits the sensitivity of the sampling system at desired frequencies offset 100 Hz to 10 MHz away from a large blocking signal. Little can be done to improve the in-close phase noise performance without the use of an additional PLL. Broadband noise added in the clock path limits the sensitivity of the whole spectrum and may be improved by using lower noise devices or by inserting a band-pass filter (BPF) with a narrow pass band and low insertion loss to the clock input signal path. Adding a BPF limits the transition rate of the clock, thereby creating a trade-off between the additive jitter added by the ADC clock receiver and the broadband noise added by the devices that drive the clock input.

Additional noise may couple to the clock path through power supplies. Take care to provide a very-low noise power supply and isolated supply return path to minimize noise added to the supply. Spurious noise added to the clock path results in symmetrical, modulated spurs around large input signals. These spurs have a constant magnitude in units of dB relative to the input signal amplitude or carrier, [dBc].

9.1.2.3 Driving the SYSREF Input

The SYSREF input interface circuit is composed of the differential receiver, internal common-mode bias, SYSREF offset feature, and SYSREF detection feature.

A high impedance (10-k Ω) reference biases the input common-mode through internal 1-k Ω termination resistors. The bias voltage is similar to the CLKIN input common-mode bias, but the internal differential termination is different. The SYSREF input requires an external 100- Ω termination. A network of resistors and switches are included at the input interface to provide a programmable DC offset, referred to as the SYSREF offset feature. This feature is configurable through the SPI and may be utilized to force a voltage offset at the SYSREF input in the absence of an active SYSREF signal. Following the receiver, an AND gate provides a method for detecting or ignoring incoming SYSREF events.

The timing relationship between the CLKIN and SYSREF signal is very important in a JESD204B system. Therefore, the signal path network of the CLKIN and SYSREF signals must be as similar as possible to ensure that the signal relationship is maintained from the launch of the signal, through their respective channels to the CLKIN and SYSREF input receivers.

TI recommends AC coupling for the SYSREF interface as shown in Figure 50. This network closely resembles the AC coupled interface of the CLKIN input shown in Figure 46 with the exception of the 100- Ω termination resistor on the source side of the AC coupling capacitors. This resistor is intentionally placed on the source side of the AC coupling capacitors, so that the termination does not interfere with the DC biasing capabilities of the SYSREF offset feature. In the case of AC coupling, the coupling capacitors of both the CLKIN and SYSREF interfaces, as well as the SYSREF termination resistor, must be placed as close as possible to the pins of the ADC14X250 device.

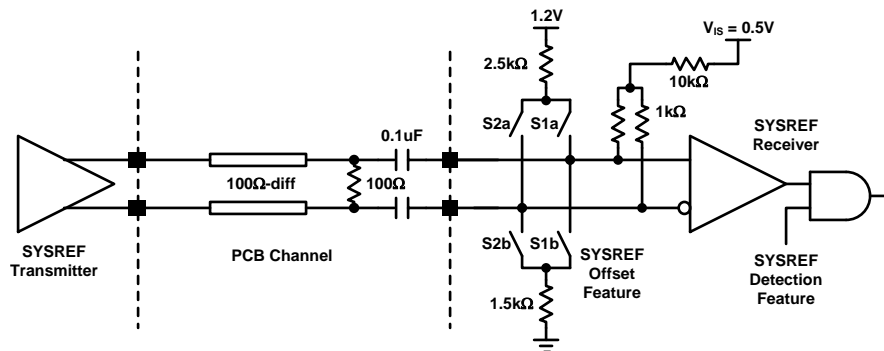

Figure 50. SYSREF Input Receiver and AC Coupled Interface

DC coupling of the SYSREF interface is possible, but not recommended. DC coupling allows all possible SYSREF signaling types to be used without the use of the SYSREF offset feature, but it has strict common-mode range requirements. The example DC coupled configuration of Figure 51 uses the same technique for the CLKIN example DC coupled interface and also includes the 100- Ω external termination. A drawback of the example DC coupled interface is that the resistor divider draws a constant DC current that must be sourced by the SYSREF transmitter.

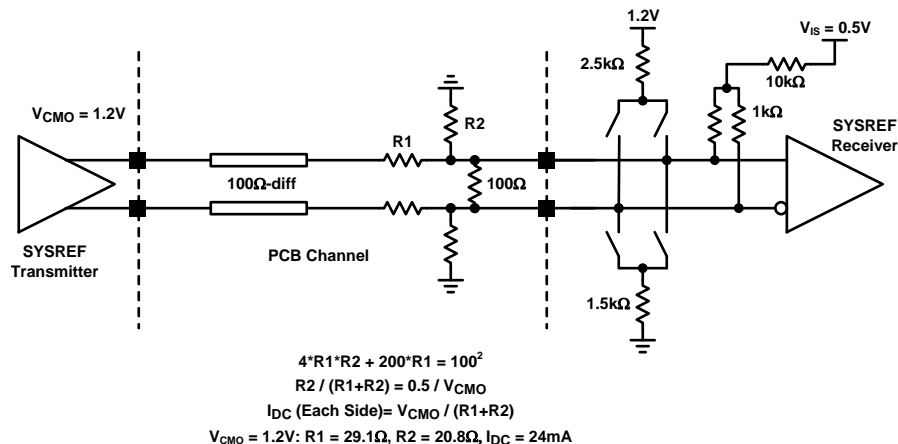

Figure 51. Example DC Coupling to the SYSREF Input

9.1.2.4 SYSREF Signaling

The SYSREF input may be driven by a number of different types of signals. The supported signal types, shown in Figure 52 (in single-ended form), include periodic, gapped periodic, and one-shot signals. The rising edge of the SYSREF signal is used as a reference to align the internal frame clock and local multi-frame clock (LMFC). To ensure proper alignment of these system clocks, the SYSREF signal must be generated along with the CLKIN signal such that the SYSREF rising edge meets the setup and hold requirements relative to the CLKIN at the ADC14X250 device inputs.

For each rising clock edge that is detected at the SYSREF input, the ADC14X250 device compares the current alignment of the internal frame and LMFC with the SYSREF edge and determines if the internal clocks must be re-aligned. In the case that no alignment is needed, the clocks maintain their current alignment and the JESD204B data link is not broken. In the case that re-alignment is needed, the JESD204B data link is broken and the clocks are re-aligned.

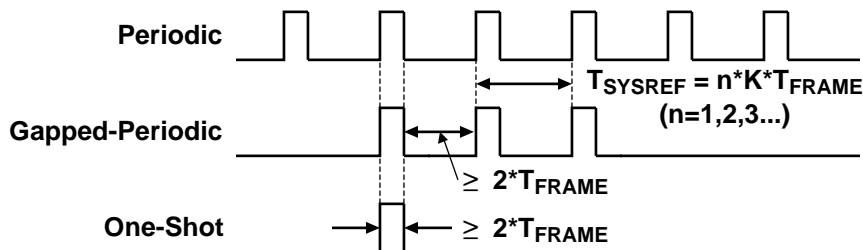

Figure 52. SYSREF Signal Types (Single-Ended Representations)

In the case of a periodic SYSREF signal, the frame and LMFC alignment is established at the first rising edge of SYSREF, and every subsequent rising edge (that properly meets setup and hold requirements) is ignored because the alignment has already been established. A periodic SYSREF must have a period equal to $n \times K / F_S$ where ' F_S ' is the sampling rate, ' K ' is the JESD204B configuration parameter indicating the number of frames per multi-frame, and ' n ' is an integer of one or greater. The duty cycle of the SYSREF signal should be greater than $2 / K$ but less than $(K - 2) / K$.

Gapped-period signals contain bursts of pulses. The frame and LMFC alignments are established on the first rising edge of the pulse burst. The rising edges within the pulse burst must be spaced apart by $n \times K / F_S$ seconds, similar to the periodic SYSREF signal. Any rising edge that does not abide by this rule or does not meet the setup and hold requirements forces re-alignment of the clocks. The duty cycle requirements are the same as the periodic signal type.

A one-shot signal contains a single rising edge that establishes the frame and LMFC alignment. The single pulse duration must be $2 \times T_{FRAME}$ or greater.

TI recommends gapped-periodic or one-shot signals for most applications so that the SYSREF signal is not active during normal sampling operation. Periodic signals that toggle constantly introduce spurs into the signal spectrum that degrade the sensitivity of the system.

9.1.2.5 SYSREF Timing

The SYSREF timing requirements depend on whether deterministic latency of the JESD204B link is required.

If deterministic latency is required, then the SYSREF signal must meet setup and hold requirements relative to the CLKIN signal. In the case that the internal CLKIN divider is used and a very high-speed signal is provided to the CLKIN input, the SYSREF signal must meet setup and hold requirements relative to the very high-speed signal at the CLKIN input.

If deterministic latency is not required, then the SYSREF signal may be supplied as an asynchronous signal (possibly achieving $< \pm 2$ frame clock cycles latency variation) or not provided at all (resulting in latency variation as large as the multi-frame period).

9.1.2.6 Effectively Using the SYSREF Offset and Detection Gate Features

Selecting the proper settings for the SYSREF offset feature depends on the condition of SYSREF in the idle state and the type of SYSREF signal being transmitted. Table 24 describes the possible SYSREF idle cases and the corresponding SYSREF offset to apply.

TI recommends the use of the SYSREF detection gate for most applications. The gate is enabled when SYSREF is being transmitted and the gate is disabled before the SYSREF transmitter is put in the idle state. Although the SYSREF offset feature does not support situations where the SYSREF transmitter is in a 0 V or Hi-Z common-mode condition during the idle state, the SYSREF gate can be used to ignore the SYSREF input during those conditions. In those cases, time is required to dissipate the voltage build-up on the AC coupling capacitors when the SYSREF returns to an active state.

Enabling the SYSREF gate immediately sends a logic signal to a logic block responsible for aligning the internal frame clock and LMFC. If the signal at the SYSREF input is logic high when the gate is enabled, then a "false" rising edge event causes a re-alignment of the internal clocks, despite the fact that the event is not an actual SYSREF rising edge. The SYSREF rising edge following the gate enable then causes a subsequent re-alignment with the desired alignment.

TI highly recommends the SYSREF clocking schemes described in Table 25.

Table 24. SYSREF Offset Feature Usage Cases

SYSREF Signal Type	SYSREF Idle V_{OD} at TX	SYSREF Idle Common-Mode (V_{IS}) at the Transmitter	SYSREF Offset Feature Setting
Periodic	N/A	N/A	0 mV
Gapped-periodic or One-shot	= 0	V_{IS} same during idle and non-idle states	0 mV
	> 0 (logic high)	V_{IS} same during idle and non-idle states	+400 mV
	< 0 (logic low)	V_{IS} same during idle and non-idle states	-400 mV
Any	0	0	SYSREF offset feature does not support these cases
	Hi-Z	Hi-Z	

Table 25. Recommended SYSREF Clocking Schemes

Coupling	SYSREF Type	SYSREF at TX During Idle State	SYSREF Rx Offset Setting	SYSREF Detection Gate
AC Coupled	One-shot or gapped-periodic ⁽¹⁾	V_{OD} logic low, V_{IS} does not change during idle	-400 mV at all times	Disabled during SYSREF idle, enabled during LMFC alignment
DC Coupled	One-shot or gapped-periodic	V_{OD} either logic state, V_{IS} does not change during idle	0 mV at all times	Disabled during SYSREF idle, enabled during LMFC alignment

(1) A gapped-periodic signal used in this recommended clocking scheme must have a pulse train duration of less than the RC time constant where $R = 50 \Omega$ and C is the value of the AC coupling capacitor. Using a 0.1- μ F capacitor, the pulse train should be less than 5 μ s.

9.1.2.7 Driving the SYNCb Input

The SYNCb input is part of the JESD204B interface and is used to send synchronization requests from the serial data receiver to the transmitter, the ADC14X250 device. The SYNCb signal, quantified as the (SYNCb+ – SYNCb–), is a differential active low signal. In the case of the ADC14X250 device, a JESD204B subclass 1 device, a SYNCb assertion (logic low) indicates a request for synchronization by the receiver.

The SYNCb input is a differential receiver as shown in Figure 53. Resistors provide an internal 100-Ω differential termination as well as a voltage divider circuit that gives the SYNCb receiver a wide input common-mode range. The SYNCb signal must be DC coupled from the driver to the SYNCb inputs; therefore, the wide common-mode range allows the use of many different logic standards including LVDS and LVPECL. No additional external components are needed for the SYNCb signal path as shown in the interface circuit of Figure 53, but providing an electrical probing site is recommended for system debug.

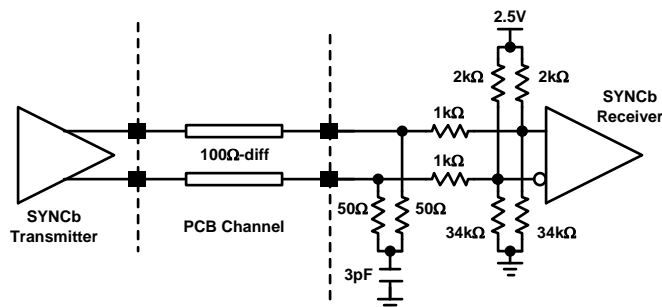

Figure 53. SYNCb Input Receiver and Interface

The SYNCb input is an asynchronous input and does not have sub-clock-cycle setup and hold requirements relative to the CLKIN or any other input to the ADC14X250 device. The SYNCb input also does not have setup and hold requirements relative to the frame and LMFC system clocks.

In the case that the JESD204B sync~ signal is provided via SPI with SYNC_SEL = 1, the SYNCb+/- pin interface may remain not connected.

9.1.3 Output Serial Interface Considerations

9.1.3.1 Output Serial-Lane Interface

The output high speed serial lanes must be AC coupled to the receiving device with 0.01-μF capacitors as shown in Figure 54. DC coupling to the receiving device is not supported. The lane channel on the PCB must be a 100-Ω differential transmission line with dominant coupling between the differential traces instead of to adjacent layers. The lane must terminate at a 100-Ω termination inside the receiving device. Avoid changing the direction of the channel traces abruptly at angles larger than 45°.

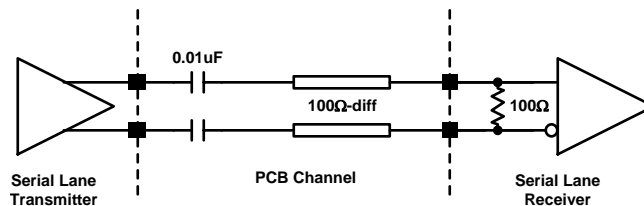

Figure 54. High-Speed Serial-Lane Interface

The recommended spacing between serial lanes is 3x the differential line spacing or greater. High speed serial lanes should be routed on top of or below adjacent, quiet ground planes to provide shielding. TI recommends that other high speed signal traces do not cross the serial lanes on adjacent PCB layers. If absolutely necessary, crossing should occur at a 90° angle with the trajectory of the serial lane to minimize coupling.

The integrity of the data transfer from the transmitter to receiver is limited by the accuracy of the differential lane characteristic impedance and the attenuation as the signal travels down the lane. Inaccurate or varying impedance and frequency dependent attenuation results in increased ISI (part of deterministic jitter) and reduced signal-to-noise ratio, which limits the ability of the receiver to accurately recover the data.

Two features are provided in the ADC14X250 device serial transmitters to compensate attenuation and ISI caused by the serial lane: voltage swing control (VOD) and de-emphasis (DEM).

9.1.3.2 Voltage Swing and De-Emphasis Optimization

Voltage swing control (VOD) compensates for attenuation across all frequencies through the channel at the expense of power consumption. Increasing the voltage swing increases the power consumption. De-emphasis (DEM) compensates for the frequency dependent attenuation of the channel but results in attenuation at lower frequencies. The voltage swing control and de-emphasis feature may be used together to optimally compensate for attenuation effects of the channel.

The frequency response of the PCB channel is typically lowpass with more attenuation occurring at higher frequencies. The de-emphasis implemented in the ADC14X250 device is a form of linear, continuous-time equalization that shapes the signal at the transmitter into a high-pass response to counteract the low-pass response of the channel. The de-emphasis setting should be selected such that the equalizer's frequency response is the inverse of the channel's response. Therefore, transferring data at the highest speeds over long channel lengths requires knowledge of the channel characteristics.

Optimization of the de-emphasis and voltage swing settings is only necessary if the ISI and losses caused by the channel are too great for reception at the desired bit rate. Many applications will perform with an adequate BER using the default settings.

9.1.3.3 Minimizing EMI

High data-transfer rates have the potential to emit radiation. EMI may be minimized using the following techniques:

- Use differential stripline channels on inner layer sandwiched between ground layers instead of routing microstrip pairs on the top layer.
- Avoid routing lanes near the edges of boards.
- Enable data scrambling to spread the frequency content of the transmitted data.
- If the serial lane must travel through an interconnect, choose a connector with good differential pair channels and shielding.
- Ensure lanes are designed with an accurate, 100- Ω characteristic impedance and provide accurate 100- Ω terminations inside the receiving device.

9.1.4 JESD204B System Considerations

9.1.4.1 Frame and LMFC Clock Alignment Procedure

Frame and LMFC clocks are generated inside the ADC14X250 device and are used to properly align the phase of the serial data leaving the device. The phases of the frame and multi-frame clocks are determined by the frame alignment step for JESD204B link initialization as shown in [Figure 36](#). These clocks are not accessible outside the device. The frequencies of the frame and LMFC must be equal to the frame and LMFC of the device receiving the serial data.

When the ADC14X250 device is powered-up, the internal frame and local multi-frame clocks initially assume a default phase alignment. To ensure determinist latency through the JESD204B link, the frame and LMFC clocks of the ADC14X250 device must be aligned in the system. Perform the following steps to align the ADC14X250 device clocks:

1. Enable the SYSREF signal driver. See [SYSREF Signaling](#) for more information.
2. Configure the SYSREF offset feature appropriately based on the SYSREF signal and channel. See [Effectively Using the SYSREF Offset and Detection Gate Features](#) for more information.
3. Enable detection of the SYSREF signal at the ADC14X250 device by enabling the SYSREF detection gate.
4. Apply the desired SYSREF signal at the ADC14X250 device SYSREF input.
5. Disable detection of the SYSREF signal by disabling the SYSREF gate.

6. Configure the SYSREF driver into its idle state.

9.1.4.2 Link Interruption

The internal frame and multi-frame clocks must be stable to maintain the JESD204B link. The ADC14X250 is designed to maintain the JESD204B link in most conditions but some features interrupt the internal clocks and break the link.

The following actions cause a break in the JESD204B link:

- The ADC14X250 device is configured into power-down mode or sleep mode
- The ADC14X250 device CLKIN clock divider setting is changed
- The serial data receiver performs a synchronization request
- The ADC14X250 device detects a SYSREF assertion that is not aligned with the internal frame or multi-frame clocks
- The CLKIN input is interrupted
- Power to the device is interrupted

The following actions do not cause a change in clock alignment nor break the JESD204B link:

- The ambient temperature or operating voltages are varied across the ranges specified in the normal operating conditions.
- The ADC14X250 device detects a SYSREF assertion that is aligned with the internal frame and multi-frame clocks.

9.1.4.3 Clock Configuration Examples

The features provided in the ADC14X250 device allow for a number of clock and JESD204B link configurations. These examples in [Table 26](#) show some common implementations and may be used as a starting point for a more customized implementation.

Table 26. Example ADC14X250 Clock Configurations

Parameter	Example 1	Example 2	Example 3
CLKIN Frequency	250 MHz	1000 MHz	2000 MHz
CLKIN Divider	1	4	8
Sampling Rate	250 MSPS	250 MSPS	250 MSPS
K (Frames per Multi-frame)	20	32	16
LMFC Frequency	12.5 MHz	7.8125 MHz	15.625 MHz
SYSREF Frequency ⁽¹⁾	12.5 MHz	7.8125 MHz	15.625 MHz
Serial Bit Rate	5.0 Gb/s	5.0 Gb/s	5.0 Gb/s

(1) The SYSREF frequency for a continuous SYSREF signal can be the indicated frequency f_{LMFC} or integer sub-harmonic such as $f_{LMFC} / 2$, $f_{LMFC} / 3$, and so forth. Gapped-periodic SYSREF signals should have pulses spaced by the associated periods $1 / f_{LMFC}$, $2 / f_{LMFC}$, $3 / f_{LMFC}$, and so forth.

9.1.4.4 Configuring the JESD204B Receiver

The ASIC or FPGA device that receives the JESD204B data from the ADC14X250 device must be configured properly to interpret the serial stream. [Table 4](#) describes the JESD204B parameter information transmitted during the ILA sequence and may be used to dynamically configure the receiving device. Due to the various arrangements of output data across different operational modes, some parameters (N, N', CS, CF) do not always reflect the data properties in all modes. Therefore, the ILA information does not completely describe the data output from the ADC14X250 device in all modes.

9.1.5 SPI

Figure 55 demonstrates a typical circuit to interface the ADC14X250 device to a SPI master using a shared SPI bus. The 4-wire interface (SCLK, SDI, SDO, CSb) is compatible with 1.2-, 1.8-, 2.5-, or 3-V logic. The input pins (SCLK, SDI, CSb) utilize thick-oxide devices to tolerate 3-V logic although the input threshold levels are relative to 1.2-V logic. The SDO output logic level is programmed in the the SPI_CFG. Until this register is properly configured, voltages on the SDO output may be as high as the $V_{A3.0}$ supply during a read command. The default state of SDO is to output 3 V logic levels during a read command. A low-capacitance protection diode may also be added with the anode connected to the SDO output and the cathode connected to the desired voltage supply to prevent an accidental pre-configured read command from causing damage.

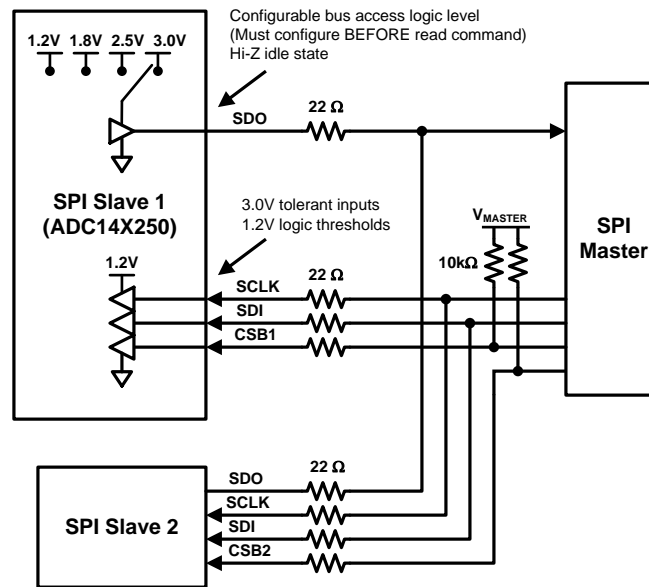

Figure 55. Typical SPI Application

9.2 Typical Applications

The ADC14X250 device is architected to fit seamlessly into most high intermediate frequency (IF) receiver applications where low noise and low distortion are required. An example block diagram is shown in Figure 56 where the ADC14X250 device is used in the receive path as well as the transmitter observation path to accommodate digital pre-distortion. The 250-MHz sampling rate provides a wide spectrum bandwidth and performance to support the newest cellular standards like LTE as well as the mature multi-carrier standards like GSM and UMTS. The device supports diversity and MIMO architectures and multi-band receivers. The back-end JESD204B interface reduces the space required to transfer data and provides a standard interface that can migrate to future generations of products, making it optimal for highly-channelized applications.

Typical Applications (continued)

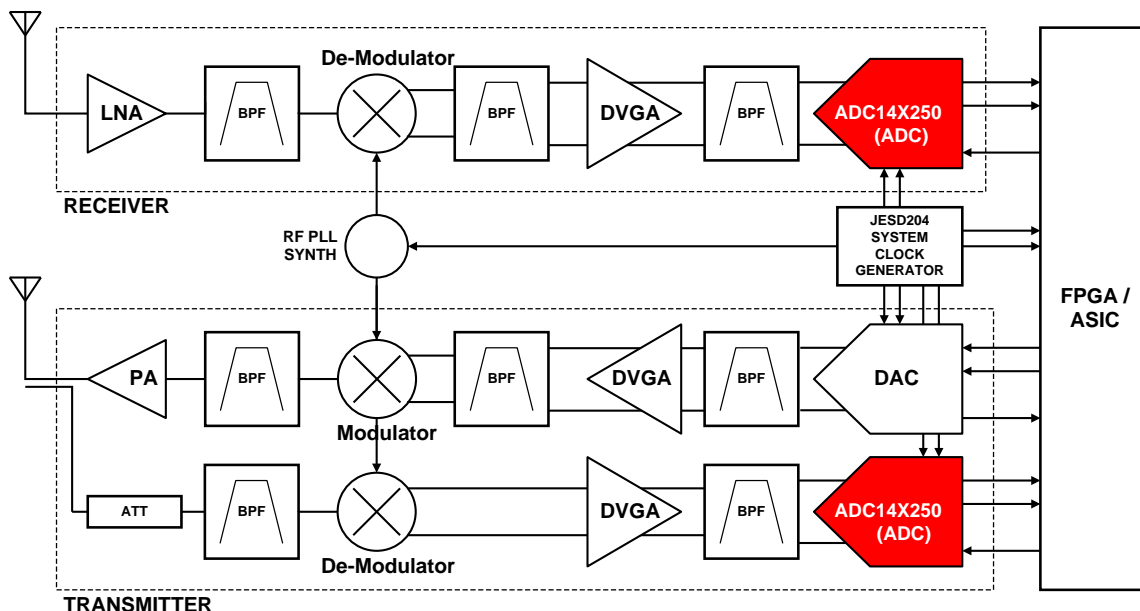

Figure 56. High IF Receiver and Transmitter With Digital Pre-Distortion Path

9.2.1 Design Requirements

The following are example design requirements expected of the ADC in a typical high-IF, 100-MHz bandwidth receiver, and is met by the ADC14X250 device:

Table 27. Example Design Requirements for a High-IF Application

Specification	Example Design Requirement ⁽¹⁾	ADC14X250 Capability
Sampling Rate	250-MSPS	Up to 250-MSPS
Input Bandwidth	> 400-MHz, 1-dB flatness	500-MHz, 1dB Bandwidth
Full Scale Range	< 2-V _{pp} -diff	1.7-V _{pp} -diff
Small Signal Noise Spectral Density	< -150-dBFS/Hz	-152.1-dBFS/Hz
Large Signal SNR	> 69-dBFS for a -3 dBFS, 240-MHz Input	70.1-dBFS for a -3 dBFS, 240-MHz Input
SFDR	> 80-dBFS for a -3 dBFS, 240-MHz input	87-dBFS for a -3 dBFS, 240-MHz input
HD2, HD3	< -80-dBFS for a -3 dBFS, 240-MHz input	-87-dBFS for a -3 dBFS, 240-MHz input
Next Largest SPUR	< -85-dBFS for a -3 dBFS, 240-MHz input	-92-dBFS for a -3 dBFS, 240-MHz input
Digital Interface	JESD204B interface, 1 lane/channel, < 10-Gb/s bit rate	JESD204B subclass 1 interface, 1 lane, 5.0-Gb/s bit rate
Configuration Interface	SPI configuration, 4-wire, 1.8-V logic, SCLK up to 20-MHz	SPI configuration, 4-Wire, 1.8-V Logic, SCLK > 20-MHz
Package Size	< 8 × 8 × 1 mm	5 × 5 × 0.8 mm

(1) These example design requirements do not represent the capabilities of the ADC14X250, rather the requirements are satisfied by the ADC14X250.

9.2.2 Design Procedure

The following procedure can be followed to design the ADC14X250 device into most applications:

- Choose an appropriate ADC driver and analog input interface.
 - Optimize the signal chain gain leading up to the ADC to make use of the full ADC dynamic range.
 - Identify whether DC or AC coupling is required.
 - Determine the desired analog input interface, such as a bandpass filter or a transformer.
 - Use the provided input network models to design and verify the interface.

- Refer to the interface recommendations in [Analog Input Considerations](#).
- Determine the core sampling rate of the ADC.
 - Must satisfy the bandwidth requirements of the application .
 - Must also provide enough margin to prevent aliasing or to accommodate the transitions bands of an anti-aliasing filter.
 - Ensure the application initialization sequence properly handles ADC core calibration as described in [ADC Core Calibration](#).
- Determine the system latency requirements.
 - Total allowable latency through the ADC and JESD204B link.
 - Is the system tolerant of latency variation over time or conditions or between power cycles?
- Determine the desired JESD204B link configuration as discussed in [JESD204B Supported Features](#).
 - Based on the system latency requirements, determine whether deterministic latency is required across the JESD204B link.
 - Choose the number of frames per multi-frame, K.
 - Choose whether scrambling is desired.
- Choose an appropriate clock generator, CLKIN interface, and SYSREF interface.
 - Determine the system clock distribution scheme and the clock frequencies for the CLKIN and SYSREF inputs.
 - Determine the allowable amount of sampling clock phase noise in the system and then select a CLKIN edge rate that satisfies this requirement as discussed in [Clock Noise and Edge Rate](#).
 - Choose an appropriate CLKIN interface as discussed in [Driving the CLKIN+ and CLKIN– Input](#).
 - Based on the latency requirements, determine whether SYSREF must meet setup and hold requirements relative to CLKIN.
 - Choose the SYSREF signal type as discussed in [SYSREF Signaling](#).
 - Choose an appropriate SYSREF interface as discussed in [Driving the SYSREF Input](#).
 - Choose a CLKIN and SYSREF clock generator based on the above requirements. The signals need come from the same generator in some cases.
 - Determine what clock idle modes are supported by the SYSREF clock generator and choose the appropriate setting for the SYSREF Offset feature as discussed in [Effectively Using the SYSREF Offset and Detection Gate Features](#) .
- Design the SYNCb interface as discussed in [Driving the SYNCb Input](#).
- Choose appropriate configurations for the output serial data interface.
 - Design the serial lane interface according to [Output Serial-Lane Interface](#).
 - Choose the required PCB materials, keeping in mind the desired rate of the serial lanes.
 - Characterize the signal lane channels the connect the ADC serial output transmitters to the receiving device either through simulation or bench characterization.
 - Optimize the VOD and DEM parameters to achieve the required signal integrity according to [Voltage Swing and De-Emphasis Optimization](#).
- Design the SPI bus interface.
 - Verify the electrical and functional compatibility of the ADC SPI with the SPI controller.
 - Interface the ADC to the SPI bus according to [SPI](#).
 - Ensure that the application initialization sequence properly configures the output SDO voltage before the first read command.
- Design the power supply architecture and de-coupling.
 - Choose appropriate power supply and supply filtering devices to provide stable, low-noise supplies as described in [Power Supply Design](#).
 - Design the capacitive de-coupling around the ADC, also described in [Power Supply Design](#), while paying close attention to placing the capacitors as close to the device as possible.
 - Time the power architecture to satisfy the power sequence requirements described in [Power Supply Design](#).
- Ensure that the application initialization sequence satisfies the JESD204B link initialization requirements described in [JESD204B Link Initialization](#).

9.2.3 Application Performance Plot

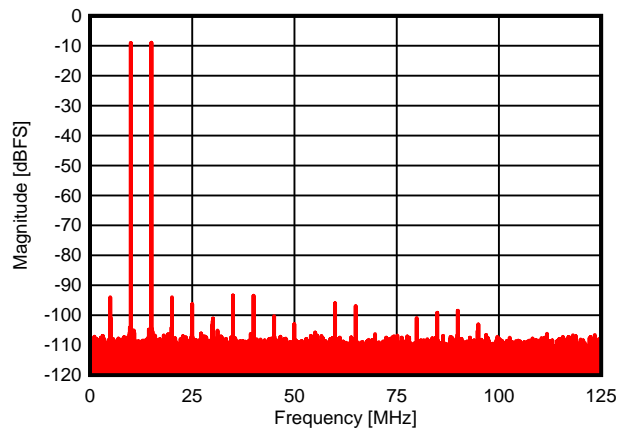

F1 = 235 MHz; F2 = 240 MHz

Figure 57. 2-Tone IMD3 Performance

ADC14X250

SLASE49B – DECEMBER 2015 – REVISED APRIL 2017

www.ti.com

9.2.4 Systems Example

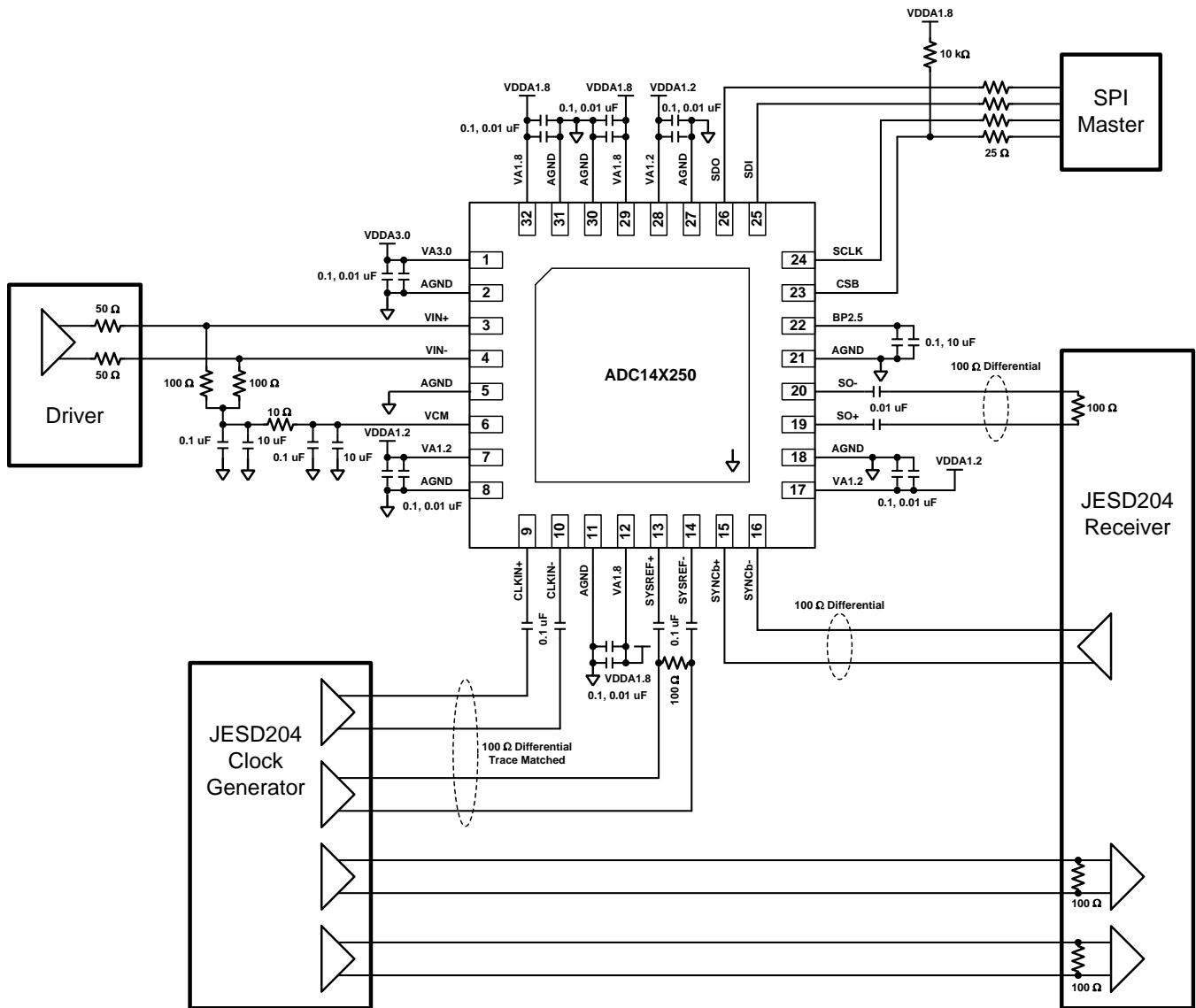

Figure 58. High-IF Sampling Receiver

10 Power Supply Recommendations

10.1 Power Supply Design

The ADC14X250 device is a very-high dynamic range device and therefore requires very-low noise power supplies. LDO-type regulators, capacitive decoupling, and series isolation devices like ferrite beads are all recommended.

LDO-type low noise regulators should be used to generate the 1.2-, 1.8-, and 3-V supplies used by the device. To improve power efficiency, a switching-type regulator may precede the LDO to efficiently drop a supply to an intermediate voltage that satisfies the drop-out requirements of the LDO. TI recommends to follow a switching-type regulator with an LDO to provide the best filtering of the switching noise. Additional ferrite beads and LC filters may be used to further suppress noise. Supplying power to multiple devices in a system from one regulator may result in noise coupling between the multiple devices; therefore, series isolation devices and additional capacitive decoupling is recommended to improve the isolation.

The power supplies must be applied to the ADC14X250 device in this specific order:

1. VA3.0
2. VA1.8
3. VA1.2

First, the VA3.0 (+3.0 V) must be applied to provide the bias for the ESD diodes. The VA1.8 (+1.8-V) supply should be applied next, followed by the VA1.2 (+1.2-V) supply. As a guideline, each supply should stabilize to within 20% of the final value within 10 ms and before enabling the next supply in the sequence. If the stabilization time is longer than 10 ms, then the system should perform the calibration procedure after the supplies have stabilized. Turning power supplies off should occur in the reverse order.

In the case of a DC coupled interface with driving amplifier, the ADC supplies should be enabled and allowed to stabilize at least 1 ms before enabling the supply of driving amplifier. The sequencing delay allows the capacitors in the common-mode control loop to charge and avoids reliability concerns related to driving the ADC input outside the VIN \pm absolute maximum range for an extended time.

10.2 Decoupling

Decoupling capacitors must be used at each supply pin to prevent supply or ground noise from degrading the dynamic performance of the ADC and to provide the ADC with a well of charge to minimize voltage ripple caused by current transients. The recommended supply decoupling scheme is to have a ceramic X7R 0201 0.1- μ F capacitor at each supply pin. The 0201 capacitor must be placed on the same layer as the device as close to the pin as possible to minimize the AC decoupling path length from the supply pin, through the capacitor, to the nearest adjacent ground pin. The 0402 capacitor should also be close to the pins. TI does not recommend placing the capacitor on the opposite board side. Each voltage supply should also have a single 10- μ F decoupling capacitor near the device but the proximity to the supply pins is less critical.

The BP2.5 pin is an external bypass pin used for stabilizing an internal 2.5-V regulator and must have a ceramic or tantalum 10- μ F capacitor and a ceramic 0402 0.1- μ F capacitor. The 0.1- μ F capacitor should be placed as close to the BP2.5 pin as possible.

11 Layout

11.1 Layout Guidelines

- The design of the PCB is critical to achieve the full performance of the ADC14X250 device. Defining the PCB stackup should be the first step in the board design. Experience has shown that at least 6 layers are required to adequately route all required signals to and from the device. Each signal routing layer must have an adjacent solid ground plane to control signal return paths to have minimal loop areas and to achieve controlled impedances for microstrip and stripline routing. Power planes must also have adjacent solid ground planes to control supply return paths. Minimizing the spacing between supply and ground planes improves performance by increasing the distributed decoupling. The recommended stack-up for a 6-layer board design is shown in [Figure 59](#).
- Although the ADC14X250 device consists of both analog and digital circuitry, TI highly recommends solid ground planes that encompass the device and its input and output signal paths. TI does not recommend split ground planes that divide the analog and digital portions of the device. Split ground planes may improve performance if a nearby, noisy, digital device is corrupting the ground reference of the analog signal path. When split ground planes are employed, one must carefully control the supply return paths and keep the paths on top of their respective ground reference planes.
- Quality analog input signal and clock signal path layout is required for full dynamic performance. Symmetry of the differential signal paths and discrete components in the path is mandatory and symmetrical shunt-oriented components should have a common grounding via. The high frequency requirements of the input and clock signal paths necessitate using differential routing with controlled impedances and minimizing signal path stubs (including vias) when possible.
- Coupling onto or between the clock and input signal paths must be avoided using any isolation techniques available including distance isolation, orientation planning to prevent field coupling of components like inductors and transformers, and providing well coupled reference planes. Via stitching around the clock signal path and the input analog signal path provides a quiet ground reference for the critical signal paths and reduces noise coupling onto these paths. Sensitive signal traces must not cross other signal traces or power routing on adjacent PCB layers, rather a ground plane must separate the traces. If necessary, the traces should cross at 90° angles to minimize crosstalk.
- The substrate dielectric materials of the PCB are largely influenced by the speed and length of the high speed serial lanes. The affordable and common FR4 variety may not offer the consistency or loss to support very high speed transmission (> 5 Gb/s) and long lengths (> 4 inch). Although the VOD and DEM features are available to improve the signal integrity of the serial lanes, some of the highest performing applications may still require special dielectric materials such as Rogers 4350B or Panasonic Megtron 6.
- Coupling of ambient signals into the signal path is reduced by providing quiet, close reference planes and by maintaining signal path symmetry to ensure the coupled noise is common-mode. Faraday caging may be used in very noisy environments and high dynamic range applications to isolate the signal path.

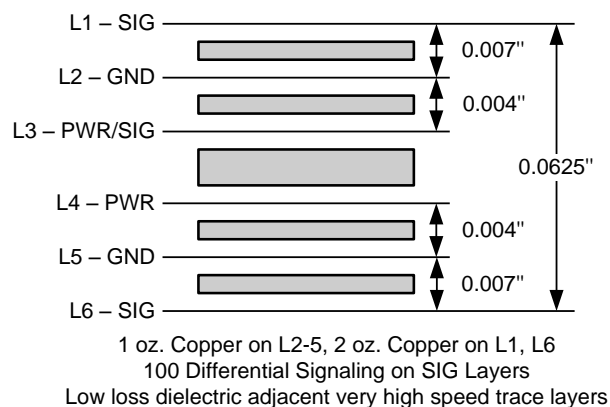

Figure 59. Recommended PCB Layer Stack-Up for a Six-Layer Board

Layout Guidelines (continued)

11.1.1 Layout Example

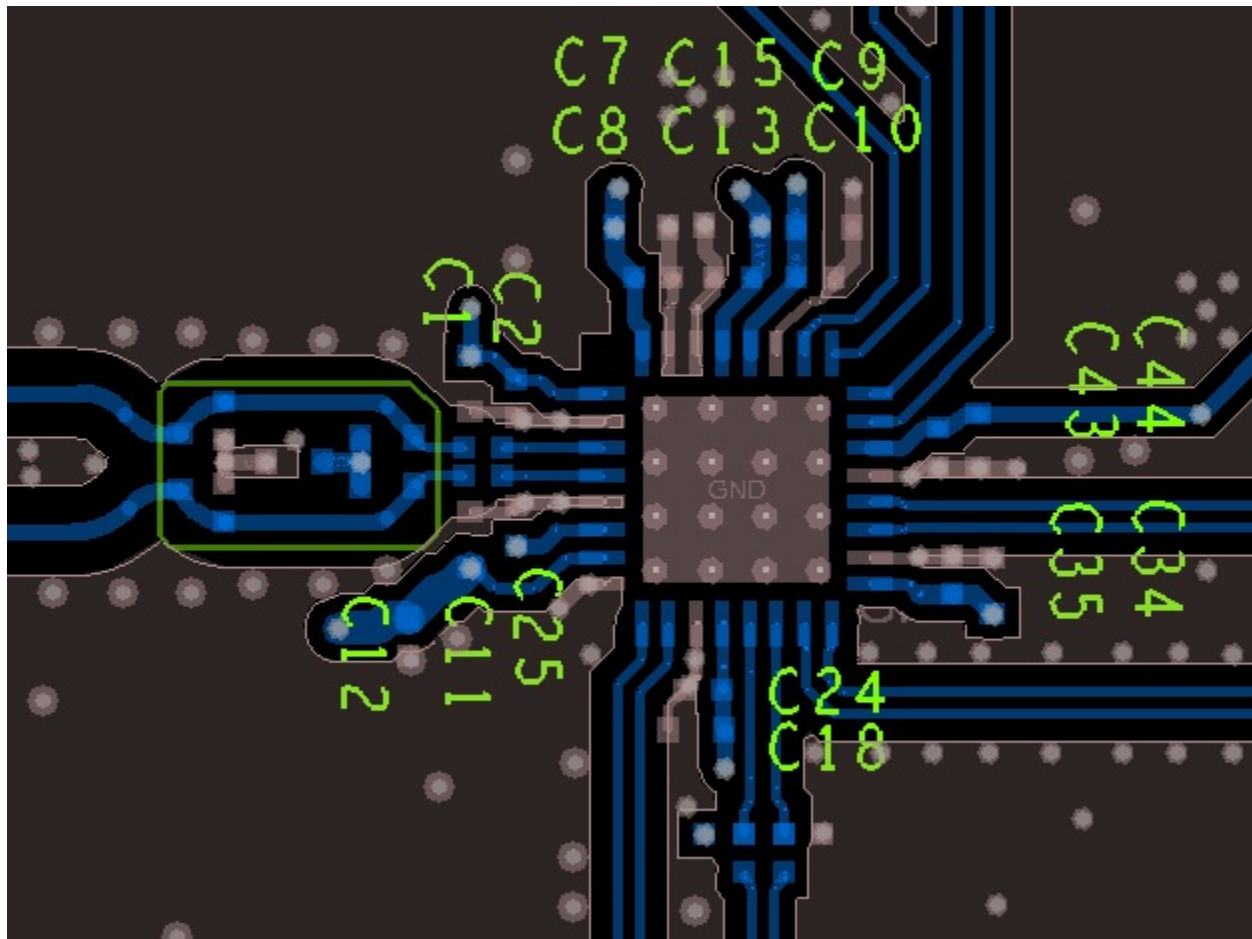

Figure 60. Example Layout

11.1.2 Thermal Considerations

The exposed thermal pad of the ADC14X250 device draws heat from the silicon down into the PCB to prevent overheating and must attach to the landing pad with a quality solder connection to maximize thermal conductivity. Overly hot operating temperatures may be alleviated further by increasing the PCB size, filling surface layers with ground planes to increase heat radiation, or using a thermally conductive connection between the package top and a heat sink.

12 Device and Documentation Support

12.1 Device Support

12.1.1 Related Documentation

See the *Isolation Glossary* ([SLLA353](#))

12.1.1.1 Specification Definitions

3-dB BANDWIDTH is a measure of the frequency at which the reconstructed output fundamental deviates 3 dB from its low frequency value relative to the differential voltage signal applied at the device input pins.

APERTURE DELAY is the time delay between the rising edge of the clock until the input signal is acquired or held for conversion.

APERTURE JITTER (APERTURE UNCERTAINTY) is the variation in aperture delay from sample to sample.

CLOCK DUTY CYCLE is the ratio of the time during one cycle that a repetitive digital waveform is high to the total time of one period. The specification here refers to the ADC clock input signal.

COMMON MODE VOLTAGE (V_{CM}) is the common DC voltage applied to both terminals of the ADC differential input.

COMMON MODE REJECTION RATIO (CMRR) is the ratio of the magnitude of the single-tone spur in the sampled spectrum (referred to the ADC analog input as a peak voltage quantity) to the peak voltage swing of a sinusoid simultaneously incident on the positive and negative terminals of a differential analog input as a common-mode signal from which the spur generated. CMRR is typically expressed in decibels [dB].

DIFFERENTIAL NON-LINEARITY (DNL) is the measure of the maximum deviation from the ideal step size of 1 least significant bit (LSB)

GAIN VARIATION is the expected standard deviation in the gain of the converter from an applied voltage to output codes between parts or between channels.

INTEGRAL NON-LINEARITY (INL) is a measure of the deviation of each individual code from a best-fit straight line. The deviation of any given code from this straight line is measured from the center of that code value.

INTERMODULATION DISTORTION (IMD) is the creation of additional spectral components as a result of two sinusoidal frequencies being applied to the ADC input at the same time. It quantifies the power of the largest intermodulation product adjacent to the input tones, expressed in dBFS.

LEAST SIGNIFICANT BIT (LSB) is the bit that has the smallest value or weight of all bits. This value is $V_{FS} / 2^n$, where V_{FS} is the full scale input voltage and n is the ADC resolution in bits.

MISSING CODES are those output codes that do not appear at the ADC outputs. The ADC14X250 device is specified not to have missing codes.

MOST SIGNIFICANT BIT (MSB) is the bit that has the largest value or weight. Its value is one half of full scale.

OFFSET ERROR is the difference between the two input voltages ($V_{IN+} - V_{IN-}$) required to cause a transition from code 8191LSB and 8192LSB with offset binary data format.

POWER SUPPLY SENSITIVITY is a measure of the sensitivity of the power supplies to noise. In this specification, a supply is modulated with a 100-mV, 500-kHz sinusoid and the resulting spurs in the spectrum are measured. The sensitivity is expressed relative to the power of a possible full-scale sinusoid [dBFS].

SAMPLE-TO-SERIAL OUT (S2SO) LATENCY is the number of frame clock cycles between initiation of conversion and the time when the first bit of serial data for that sample is present at the output driver. This latency is not specified to be deterministic.

SAMPLE-TO-PARALLEL OUT (S2PO) LATENCY is the number of frame clock cycles between initiation of conversion and the time when the parallel sample data is available at the output of the receiver's

Device Support (continued)

elastic buffer. This latency is specified to be deterministic if the JESD204B subclass 1 requirements are satisfied.

SIGNAL-TO-NOISE RATIO (SNR) is the ratio, expressed in dB, of the power of the input signal to the total power of all other spectral components, not including harmonics and DC. SNR is usually expressed relative to the power of a possible full-scale sinusoid [dBFS] or relative to the power of the actual input carrier signal [dBc].

SIGNAL-TO-NOISE AND DISTORTION (SINAD) is the ratio, expressed in dB, of the power of the input signal to the total power of all of the other spectral components, including harmonics but excluding DC. SINAD is usually expressed relative to the power of a possible full-scale sinusoid [dBFS] or relative to the power of the actual input carrier signal [dBc].

NON-HD2/HD3 SPUR is the ratio, expressed in dB, of the power of the peak spurious signal to the power of the input signal, where a spurious signal is any signal present in the output spectrum that is not present at the input excluding the second and third harmonic distortion. This parameter is usually expressed relative to the power of a possible full-scale sinusoid [dBFS] or relative to the power of the actual input carrier signal [dBc].

SPURIOUS FREE DYNAMIC RANGE (SFDR) is the ratio, expressed in dB, of the input signal power to the peak spurious signal power, where a spurious signal is any signal present in the output spectrum that is not present at the input. SINAD is usually expressed relative to the power of a possible full-scale sinusoid [dBFS] or relative to the power of the actual input carrier signal [dBc].

SECOND HARMONIC DISTORTION (2ND HARM or HD2) is the ratio, expressed in dB, of the power of the input signal's 2nd harmonic to the power of the input signal. HD2 is usually expressed relative to the power of a possible full-scale sinusoid [dBFS] or relative to the power of the actual input carrier signal [dBc].

THIRD HARMONIC DISTORTION (3RD HARM or HD3) is the ratio, expressed in dB, of the power of the input signal's 3rd harmonic to the power of the input signal. HD3 is usually expressed relative to the power of a possible full-scale sinusoid [dBFS] or relative to the power of the actual input carrier signal [dBc].

TOTAL HARMONIC DISTORTION (THD) is the ratio, expressed in dB, of the total power of the first eight harmonics (HD2 through HD9) to the input signal power. THD is usually expressed relative to the power of a possible full-scale sinusoid [dBFS] or relative to the power of the actual input carrier signal [dBc].

12.1.1.2 JESD204B Definitions

DEVICE CLOCK is a master clock signal from which a device must generate its local frame and local multi-frame clocks. For the ADC14X250 device, this refers to the signal at the CLKIN input.

FRAME is a set of consecutive octets in which the position of each octet can be identified by references to a frame alignment signal.

FRAME CLOCK is a signal used for sequencing frames or monitoring their alignment. For the ADC14X250 device, this clock is internally generated and is not externally accessible.

LINK (DATA LINK) is an assembly, consisting of parts of two devices and the interconnecting data circuit, that is controlled by a long protocol enabling data to be transferred from a data source to a data sink. The link includes portions of the ADC14X250 device (transmitter), FPGA or ASIC (receiver), and the hardware that connects them.

LOCAL MULTI-FRAME CLOCK (LMFC) is a signal used for sequencing multi-frames or monitoring their alignment. This clock is derived inside the ADC14X250 device from the device clock and used in the implementation of the JESD204B link within the device.

MULTI-FRAME is a set of consecutive frames in which the position of each frame can be identified by reference to a multi-frame alignment signal.

OCTET is a group of eight adjacent binary digits, serving as the input to an 8B/10B encoder or the output of an 8B/10B decoder.

Device Support (continued)

SCRAMBLING is the randomization of the output data that is used to eliminate long strings of consecutive identical transmitted symbols and avoid the presence of spectral lines in the signal spectrum without changing the signaling rate.

SERIAL LANE is a differential signal pair for data transmission in one direction.

SYSREF is a periodic, one-shot, or gapped periodic signal used to align the boundaries of local multi-frame clocks in JESD204B subclass 1 compliant devices. SYSREF must be source synchronous with the device clock.

12.2 Receiving Notification of Documentation Updates

To receive notification of documentation updates, navigate to the device product folder on ti.com. In the upper right corner, click on *Alert me* to register and receive a weekly digest of any product information that has changed. For change details, review the revision history included in any revised document.

12.3 Community Resources

The following links connect to TI community resources. Linked contents are provided "AS IS" by the respective contributors. They do not constitute TI specifications and do not necessarily reflect TI's views; see TI's [Terms of Use](#).

TI E2E™ Online Community *TI's Engineer-to-Engineer (E2E) Community*. Created to foster collaboration among engineers. At e2e.ti.com, you can ask questions, share knowledge, explore ideas and help solve problems with fellow engineers.

Design Support *TI's Design Support* Quickly find helpful E2E forums along with design support tools and contact information for technical support.

12.4 Trademarks

E2E is a trademark of Texas Instruments.
All other trademarks are the property of their respective owners.

12.5 Electrostatic Discharge Caution



These devices have limited built-in ESD protection. The leads should be shorted together or the device placed in conductive foam during storage or handling to prevent electrostatic damage to the MOS gates.

12.6 Glossary

SLYZ022 — *TI Glossary*.

This glossary lists and explains terms, acronyms, and definitions.

13 Mechanical, Packaging, and Orderable Information

The following pages include mechanical packaging and orderable information. This information is the most current data available for the designated devices. This data is subject to change without notice and revision of this document. For browser-based versions of this data sheet, refer to the left-hand navigation.

PACKAGING INFORMATION

Orderable Device	Status (1)	Package Type	Package Drawing	Pins	Package Qty	Eco Plan (2)	Lead/Ball Finish (6)	MSL Peak Temp (3)	Op Temp (°C)	Device Marking (4/5)	Samples
ADC14X250RHBR	ACTIVE	VQFN	RHB	32	3000	Green (RoHS & no Sb/Br)	CU NIPDAUAG	Level-3-260C-168 HR	-40 to 85	14X250	Samples
ADC14X250RHBT	ACTIVE	VQFN	RHB	32	250	Green (RoHS & no Sb/Br)	CU NIPDAUAG	Level-3-260C-168 HR	-40 to 85	14X250	Samples

(1) The marketing status values are defined as follows:

ACTIVE: Product device recommended for new designs.

LIFEBUY: TI has announced that the device will be discontinued, and a lifetime-buy period is in effect.

NRND: Not recommended for new designs. Device is in production to support existing customers, but TI does not recommend using this part in a new design.

PREVIEW: Device has been announced but is not in production. Samples may or may not be available.

OBSOLETE: TI has discontinued the production of the device.

(2) Eco Plan - The planned eco-friendly classification: Pb-Free (RoHS), Pb-Free (RoHS Exempt), or Green (RoHS & no Sb/Br) - please check <http://www.ti.com/productcontent> for the latest availability information and additional product content details.

TBD: The Pb-Free/Green conversion plan has not been defined.

Pb-Free (RoHS): TI's terms "Lead-Free" or "Pb-Free" mean semiconductor products that are compatible with the current RoHS requirements for all 6 substances, including the requirement that lead not exceed 0.1% by weight in homogeneous materials. Where designed to be soldered at high temperatures, TI Pb-Free products are suitable for use in specified lead-free processes.

Pb-Free (RoHS Exempt): This component has a RoHS exemption for either 1) lead-based flip-chip solder bumps used between the die and package, or 2) lead-based die adhesive used between the die and leadframe. The component is otherwise considered Pb-Free (RoHS compatible) as defined above.

Green (RoHS & no Sb/Br): TI defines "Green" to mean Pb-Free (RoHS compatible), and free of Bromine (Br) and Antimony (Sb) based flame retardants (Br or Sb do not exceed 0.1% by weight in homogeneous material)

(3) MSL, Peak Temp. - The Moisture Sensitivity Level rating according to the JEDEC industry standard classifications, and peak solder temperature.

(4) There may be additional marking, which relates to the logo, the lot trace code information, or the environmental category on the device.

(5) Multiple Device Markings will be inside parentheses. Only one Device Marking contained in parentheses and separated by a "~" will appear on a device. If a line is indented then it is a continuation of the previous line and the two combined represent the entire Device Marking for that device.

(6) Lead/Ball Finish - Orderable Devices may have multiple material finish options. Finish options are separated by a vertical ruled line. Lead/Ball Finish values may wrap to two lines if the finish value exceeds the maximum column width.

Important Information and Disclaimer: The information provided on this page represents TI's knowledge and belief as of the date that it is provided. TI bases its knowledge and belief on information provided by third parties, and makes no representation or warranty as to the accuracy of such information. Efforts are underway to better integrate information from third parties. TI has taken and continues to take reasonable steps to provide representative and accurate information but may not have conducted destructive testing or chemical analysis on incoming materials and chemicals. TI and TI suppliers consider certain information to be proprietary, and thus CAS numbers and other limited information may not be available for release.

In no event shall TI's liability arising out of such information exceed the total purchase price of the TI part(s) at issue in this document sold by TI to Customer on an annual basis.

TAPE AND REEL INFORMATION



QUADRANT ASSIGNMENTS FOR PIN 1 ORIENTATION IN TAPE



*All dimensions are nominal

Device	Package Type	Package Drawing	Pins	SPQ	Reel Diameter (mm)	Reel Width W1 (mm)	A0 (mm)	B0 (mm)	K0 (mm)	P1 (mm)	W (mm)	Pin1 Quadrant
ADC14X250RHBR	VQFN	RHB	32	3000	330.0	12.4	5.3	5.3	1.5	8.0	12.0	Q2
ADC14X250RHBT	VQFN	RHB	32	250	180.0	12.4	5.3	5.3	1.5	8.0	12.0	Q2

TAPE AND REEL BOX DIMENSIONS

*All dimensions are nominal

Device	Package Type	Package Drawing	Pins	SPQ	Length (mm)	Width (mm)	Height (mm)
ADC14X250RHBR	VQFN	RHB	32	3000	336.6	336.6	28.6
ADC14X250RHBT	VQFN	RHB	32	250	210.0	185.0	35.0

RHB (S-PVQFN-N32)

PLASTIC QUAD FLATPACK NO-LEAD

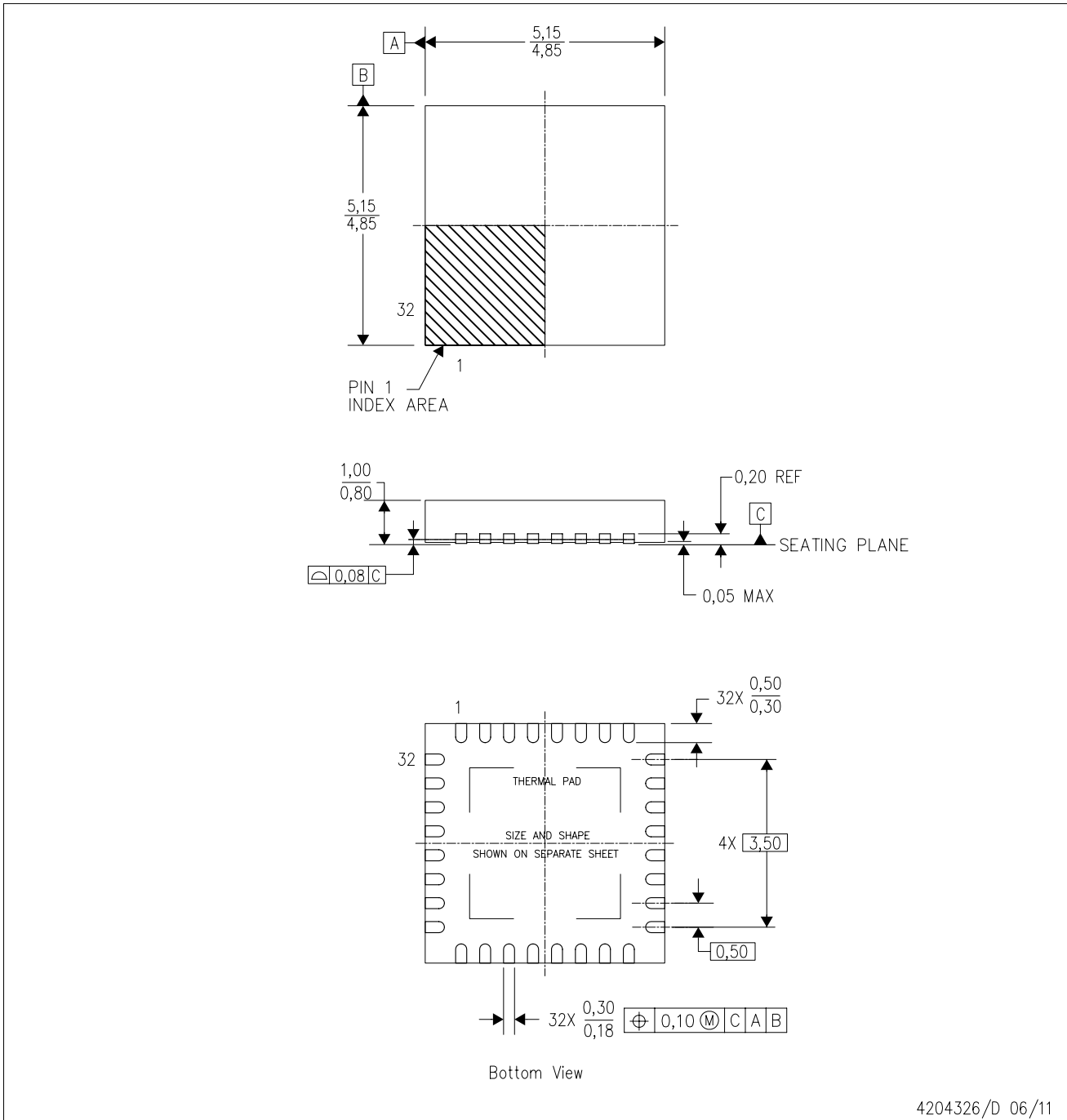

- NOTES:
- All linear dimensions are in millimeters. Dimensioning and tolerancing per ASME Y14.5M-1994.
 - This drawing is subject to change without notice.
 - QFN (Quad Flatpack No-Lead) Package configuration.
 - The package thermal pad must be soldered to the board for thermal and mechanical performance.
 - See the additional figure in the Product Data Sheet for details regarding the exposed thermal pad features and dimensions.
 - Falls within JEDEC MO-220.

IMPORTANT NOTICE

Texas Instruments Incorporated (TI) reserves the right to make corrections, enhancements, improvements and other changes to its semiconductor products and services per JESD46, latest issue, and to discontinue any product or service per JESD48, latest issue. Buyers should obtain the latest relevant information before placing orders and should verify that such information is current and complete.

TI's published terms of sale for semiconductor products (<http://www.ti.com/sc/docs/stdterms.htm>) apply to the sale of packaged integrated circuit products that TI has qualified and released to market. Additional terms may apply to the use or sale of other types of TI products and services.

Reproduction of significant portions of TI information in TI data sheets is permissible only if reproduction is without alteration and is accompanied by all associated warranties, conditions, limitations, and notices. TI is not responsible or liable for such reproduced documentation. Information of third parties may be subject to additional restrictions. Resale of TI products or services with statements different from or beyond the parameters stated by TI for that product or service voids all express and any implied warranties for the associated TI product or service and is an unfair and deceptive business practice. TI is not responsible or liable for any such statements.

Buyers and others who are developing systems that incorporate TI products (collectively, "Designers") understand and agree that Designers remain responsible for using their independent analysis, evaluation and judgment in designing their applications and that Designers have full and exclusive responsibility to assure the safety of Designers' applications and compliance of their applications (and of all TI products used in or for Designers' applications) with all applicable regulations, laws and other applicable requirements. Designer represents that, with respect to their applications, Designer has all the necessary expertise to create and implement safeguards that (1) anticipate dangerous consequences of failures, (2) monitor failures and their consequences, and (3) lessen the likelihood of failures that might cause harm and take appropriate actions. Designer agrees that prior to using or distributing any applications that include TI products, Designer will thoroughly test such applications and the functionality of such TI products as used in such applications.

TI's provision of technical, application or other design advice, quality characterization, reliability data or other services or information, including, but not limited to, reference designs and materials relating to evaluation modules, (collectively, "TI Resources") are intended to assist designers who are developing applications that incorporate TI products; by downloading, accessing or using TI Resources in any way, Designer (individually or, if Designer is acting on behalf of a company, Designer's company) agrees to use any particular TI Resource solely for this purpose and subject to the terms of this Notice.

TI's provision of TI Resources does not expand or otherwise alter TI's applicable published warranties or warranty disclaimers for TI products, and no additional obligations or liabilities arise from TI providing such TI Resources. TI reserves the right to make corrections, enhancements, improvements and other changes to its TI Resources. TI has not conducted any testing other than that specifically described in the published documentation for a particular TI Resource.

Designer is authorized to use, copy and modify any individual TI Resource only in connection with the development of applications that include the TI product(s) identified in such TI Resource. NO OTHER LICENSE, EXPRESS OR IMPLIED, BY ESTOPPEL OR OTHERWISE TO ANY OTHER TI INTELLECTUAL PROPERTY RIGHT, AND NO LICENSE TO ANY TECHNOLOGY OR INTELLECTUAL PROPERTY RIGHT OF TI OR ANY THIRD PARTY IS GRANTED HEREIN, including but not limited to any patent right, copyright, mask work right, or other intellectual property right relating to any combination, machine, or process in which TI products or services are used. Information regarding or referencing third-party products or services does not constitute a license to use such products or services, or a warranty or endorsement thereof. Use of TI Resources may require a license from a third party under the patents or other intellectual property of the third party, or a license from TI under the patents or other intellectual property of TI.

TI RESOURCES ARE PROVIDED "AS IS" AND WITH ALL FAULTS. TI DISCLAIMS ALL OTHER WARRANTIES OR REPRESENTATIONS, EXPRESS OR IMPLIED, REGARDING RESOURCES OR USE THEREOF, INCLUDING BUT NOT LIMITED TO ACCURACY OR COMPLETENESS, TITLE, ANY EPIDEMIC FAILURE WARRANTY AND ANY IMPLIED WARRANTIES OF MERCHANTABILITY, FITNESS FOR A PARTICULAR PURPOSE, AND NON-INFRINGEMENT OF ANY THIRD PARTY INTELLECTUAL PROPERTY RIGHTS. TI SHALL NOT BE LIABLE FOR AND SHALL NOT DEFEND OR INDEMNIFY DESIGNER AGAINST ANY CLAIM, INCLUDING BUT NOT LIMITED TO ANY INFRINGEMENT CLAIM THAT RELATES TO OR IS BASED ON ANY COMBINATION OF PRODUCTS EVEN IF DESCRIBED IN TI RESOURCES OR OTHERWISE. IN NO EVENT SHALL TI BE LIABLE FOR ANY ACTUAL, DIRECT, SPECIAL, COLLATERAL, INDIRECT, PUNITIVE, INCIDENTAL, CONSEQUENTIAL OR EXEMPLARY DAMAGES IN CONNECTION WITH OR ARISING OUT OF TI RESOURCES OR USE THEREOF, AND REGARDLESS OF WHETHER TI HAS BEEN ADVISED OF THE POSSIBILITY OF SUCH DAMAGES.

Unless TI has explicitly designated an individual product as meeting the requirements of a particular industry standard (e.g., ISO/TS 16949 and ISO 26262), TI is not responsible for any failure to meet such industry standard requirements.

Where TI specifically promotes products as facilitating functional safety or as compliant with industry functional safety standards, such products are intended to help enable customers to design and create their own applications that meet applicable functional safety standards and requirements. Using products in an application does not by itself establish any safety features in the application. Designers must ensure compliance with safety-related requirements and standards applicable to their applications. Designer may not use any TI products in life-critical medical equipment unless authorized officers of the parties have executed a special contract specifically governing such use. Life-critical medical equipment is medical equipment where failure of such equipment would cause serious bodily injury or death (e.g., life support, pacemakers, defibrillators, heart pumps, neurostimulators, and implantables). Such equipment includes, without limitation, all medical devices identified by the U.S. Food and Drug Administration as Class III devices and equivalent classifications outside the U.S.

TI may expressly designate certain products as completing a particular qualification (e.g., Q100, Military Grade, or Enhanced Product). Designers agree that it has the necessary expertise to select the product with the appropriate qualification designation for their applications and that proper product selection is at Designers' own risk. Designers are solely responsible for compliance with all legal and regulatory requirements in connection with such selection.

Designer will fully indemnify TI and its representatives against any damages, costs, losses, and/or liabilities arising out of Designer's non-compliance with the terms and provisions of this Notice.