

## 1:3 LVPECL CLOCK BUFFER + ADDITIONAL LVCMOS OUTPUT AND PROGRAMMABLE DIVIDER

### FEATURES

- Distributes One Differential Clock Input to Three LVPECL Differential Clock Outputs and One LVCMOS Single-Ended Output
- Programmable Output Divider for Two LVPECL Outputs and LVCMOS Output
- Low-Output Skew 15 ps (Typical) for Clock-Distribution Applications for LVPECL Outputs; 1.6-ns Output Skew Between LVCMOS and LVPECL Transitions Minimizing Noise
- $V_{CC}$  Range 3 V–3.6 V
- Signaling Rate Up to 800-MHz LVPECL and 200-MHz LVCMOS
- Differential Input Stage for Wide Common-Mode Range
- Provides VBB Bias Voltage Output for Single-Ended Input Signals
- Receiver Input Threshold  $\pm 75$  mV
- 24-Terminal QFN Package (4 mm × 4 mm)
- Accepts Any Differential Signaling: LVDS, HSTL, CML, VML, SSTL-2, and Single-Ended: LVTTTL/LVCMOS

### DESCRIPTION

The CDCM1804 clock driver distributes one pair of differential clock inputs to three pairs of LVPECL differential clock outputs  $Y[2:0]$  and  $\overline{Y}[2:0]$ , with minimum skew for clock distribution. The CDCM1804 is specifically designed for driving 50- $\Omega$  transmission lines. Additionally, the CDCM1804 offers a single-ended LVCMOS output  $Y3$ . This output is delayed by 1.6 ns over the three LVPECL output stages to minimize noise impact during signal transitions.

The CDCM1804 has three control terminals,  $S0$ ,  $S1$ , and  $S2$ , to select different output mode settings. The  $S[2:0]$  terminals are 3-level inputs and therefore allow up to  $3^3 = 27$  combinations. Additionally, an enable terminal (EN) is provided to disable or enable all outputs simultaneously. The EN terminal is a 3-level input as well and extends the number of settings to  $2 \times 27 = 54$ . See Table 1 for details.

The CDCM1804 is characterized for operation from  $-40^{\circ}\text{C}$  to  $85^{\circ}\text{C}$ .

For use in single-ended driver applications, the CDCM1804 also provides a VBB output terminal that can be directly connected to the unused input as a common-mode voltage reference.

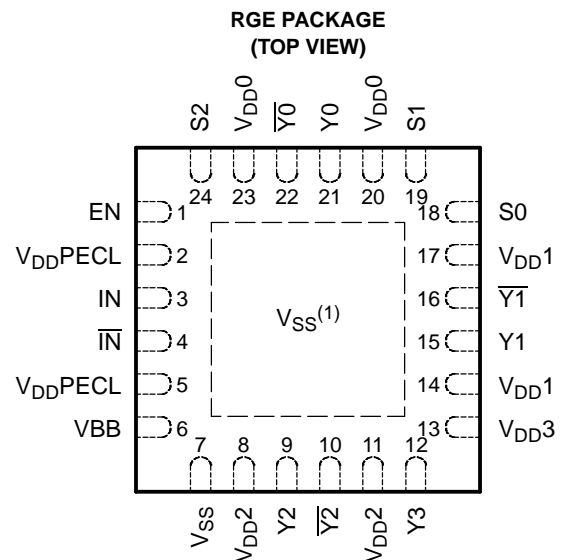

(1) Thermal pad must be connected to  $V_{SS}$ .

P0024-01

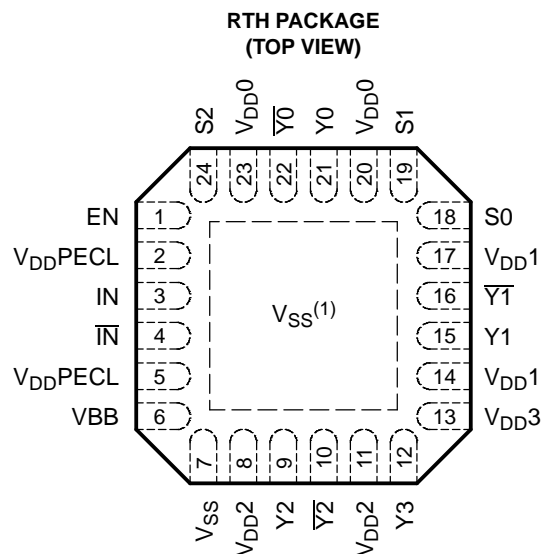

(1) Thermal pad must be connected to  $V_{SS}$ .

P0025-01



Please be aware that an important notice concerning availability, standard warranty, and use in critical applications of Texas Instruments semiconductor products and disclaimers thereto appears at the end of this data sheet.

FUNCTIONAL BLOCK DIAGRAM

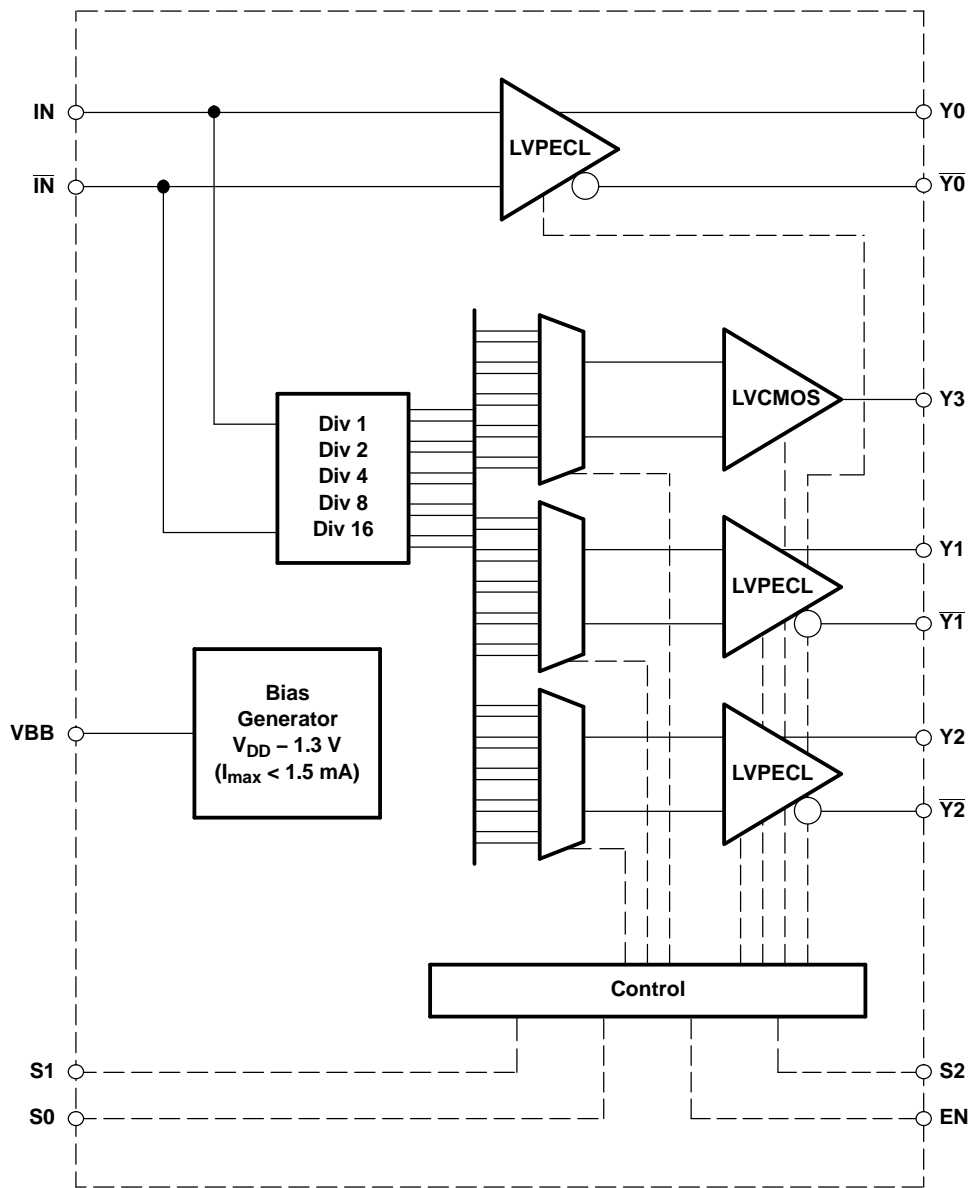

B0059-01

**TERMINAL FUNCTIONS**

TERMINAL		I/O	DESCRIPTION
NAME	NO.		
EN	1	I (with 60-kΩ pullup)	<p>ENABLE: Enables or disables all outputs simultaneously. The EN terminal offers three different configurations: tied to GND (logic 0), external 60-kΩ pulldown resistor (pull to <math>V_{DD}/2</math>), or left floating (logic 1);</p> <p>EN = 1: outputs on according to S[2:0] settings            EN = <math>V_{DD}/2</math>: outputs on according to S[2:0] settings            EN = 0: outputs Y[3:0] off (high impedance)            See <a href="#">Table 1</a> for details.</p>
IN, $\overline{IN}$	3, 4	I (differential)	<p>Differential input clock: Input stage is sensitive and has a wide common-mode range. Therefore, almost any type of differential signal can drive this input (LVPECL, LVDS, CML, HSTL). Because the input is high-impedance, it is recommended to terminate the PCB transmission line before the input (e.g., with 100 Ω across input). Input can also be driven by single-ended signal if the complementary input is tied to VBB. A more-advanced scheme for single-ended signals is given in the <i>Application Information</i> section near the end of this document.</p> <p>The inputs employ an ESD structure protecting the inputs in case of an input voltage exceeding the rails by more than ~0.7 V. Reverse biasing of the IC through these inputs is possible and must be prevented by limiting the input voltage &lt; <math>V_{DD}</math>.</p>
S[2:0]	18, 19, 24	I (with 60-kΩ pullup)	<p>Select mode of operation: Defines the output configuration of Y[3:0]. Each terminal offers three different configurations: tied to GND (logic 0), external 60-kΩ pulldown resistor (pull to <math>V_{DD}/2</math>), or left floating (logic 1); see <a href="#">Table 1</a> for details.</p>
VBB	6	O	<p>Bias voltage output to be used to bias unused complementary input <math>\overline{IN}</math> for single-ended input signals.</p> <p>The output voltage of VBB is <math>V_{DD} - 1.3</math> V. When driving a load, the output current drive is limited to about 1.5 mA.</p>
$V_{SS}$	7	Supply	Device ground
$V_{DDPECL}$	2, 5	Supply	Supply voltage LVPECL input + internal logic
$V_{DD[2:0]}$	8, 11, 14, 17, 20, 23	Supply	<p>LVPECL output supply voltage for output Y[2:0]. Each output can be disabled by pulling the corresponding <math>V_{DDx}</math> to GND.</p> <p><b>CAUTION:</b> In this mode, no voltage from outside may be forced, because internal diodes could be forced in forward direction. Thus, it is recommended to disconnect the output.</p>
$V_{DD3}$	13	Supply	<p>Supply voltage LVCMOS output. The LVCMOS output can be disabled by pulling <math>V_{DD3}</math> to GND.</p> <p><b>CAUTION:</b> In this mode, no voltage from outside may be forced because internal diodes could be forced in a forward direction. Thus, it is recommended to leave Y3 unconnected, tied to GND, or terminated into GND.</p>
Y[2:0] $\overline{Y[2:0]}$	9, 15, 21 10, 16, 22	O (LVPECL)	<p>LVPECL clock outputs. These outputs provide low-skew copies of IN or down-divided copies of clock IN based on selected mode of operation S[2:0]. If an output is unused, the output can simply be left open to save power and minimize noise impact to the remaining outputs.</p>
Y3	12	O	<p>LVCMOS clock output. This output provides copy of IN or down-divided copy of clock IN based on selected mode of operation S[2:0]. Also, this output can be disabled when <math>V_{DD3}</math> becomes tied to GND.</p>

**CONTROL TERMINAL SETTINGS**

The CDCM1804 has three control terminals (S0, S1, and S2) and an enable terminal (EN) to select different output mode settings. All four inputs (S0, S1, S2, and EN) are 3-level inputs offering 54 different combinations. In addition, the EN input allows the disabling of all outputs and forcing them into a high-z (or 3-state) output state when pulled to GND.

Each control input incorporates a 60-kΩ pullup resistor. Thus, it is easy to choose the input setting by designing a resistor pad between the control input and GND. To choose a logic zero, the resistor value must be zero. Setting the input high requires leaving the resistor pad empty (no resistor installed). For setting the input to  $V_{DD}/2$ , the installed resistor must be a 60-kΩ pulldown to GND with a 10% tolerance or better.

Setting for Mode 13:  
 EN = 1  
 S2 =  $V_{DD}/2$   
 S1 =  $V_{DD}/2$   
 S0 = 0

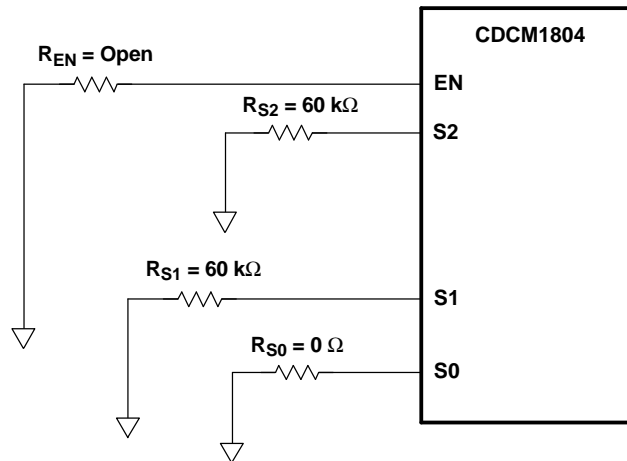

S0084-01

Figure 1. Control Terminal Setting for Example

Table 1. Selection Mode Table

MODE	EN	S2	S1	S0	LVPECL <sup>(1)</sup>			LVC MOS
					Y0	Y1	Y2	Y3
0	0	x	x	x	Off (high-z)			
1	1	0	0	0	÷ 1	÷ 1	÷ 1	Off (high-z)
2	1	0	0	$V_{DD}/2$	÷ 1	Off (high-z)	Off (high-z)	÷ 4
3	1	0	0	1	÷ 1	÷ 1	Off (high-z)	÷ 4
4	1	0	$V_{DD}/2$	0	÷ 1	÷ 2	Off (high-z)	÷ 4
5	1	0	$V_{DD}/2$	$V_{DD}/2$	÷ 1	÷ 4	Off (high-z)	÷ 4
6	1	0	$V_{DD}/2$	1	÷ 1	÷ 8	Off (high-z)	÷ 4
7	1	0	1	0	÷ 1	Off (high-z)	÷ 1	÷ 4
8	1	0	1	$V_{DD}/2$	÷ 1	÷ 1	÷ 1	÷ 4
9	1	0	1	1	÷ 1	÷ 2	÷ 1	÷ 4
10	1	$V_{DD}/2$	0	0	÷ 1	÷ 4	÷ 1	÷ 4
11	1	$V_{DD}/2$	0	$V_{DD}/2$	÷ 1	÷ 8	÷ 1	÷ 4
12	1	$V_{DD}/2$	0	1	÷ 1	Off (high-z)	÷ 2	÷ 4
13	1	$V_{DD}/2$	$V_{DD}/2$	0	÷ 1	÷ 1	÷ 2	÷ 4
14	1	$V_{DD}/2$	$V_{DD}/2$	$V_{DD}/2$	÷ 1	÷ 2	÷ 2	÷ 4
15	1	$V_{DD}/2$	$V_{DD}/2$	1	÷ 1	÷ 4	÷ 2	÷ 4
16	1	$V_{DD}/2$	1	0	÷ 1	÷ 8	÷ 2	÷ 4
17	1	$V_{DD}/2$	1	$V_{DD}/2$	÷ 1	Off (high-z)	÷ 4	÷ 4
18	1	$V_{DD}/2$	1	1	÷ 1	÷ 1	÷ 4	÷ 4
19	1	1	0	0	÷ 1	÷ 2	÷ 4	÷ 4
20	1	1	0	$V_{DD}/2$	÷ 1	÷ 4	÷ 4	÷ 4
21	1	1	0	1	÷ 1	÷ 8	÷ 4	÷ 4
22	1	1	$V_{DD}/2$	0	÷ 1	Off (high-z)	÷ 8	÷ 4
23	1	1	$V_{DD}/2$	$V_{DD}/2$	÷ 1	÷ 1	÷ 8	÷ 4
24	1	1	$V_{DD}/2$	1	÷ 1	÷ 2	÷ 8	÷ 4
25	1	1	1	0	÷ 1	÷ 4	÷ 8	÷ 4

(1) The LVPECL outputs are open-emitter stages. Thus, if you leave the unused LVPECL outputs Y0, Y1, or Y2 unconnected, then the current consumption is minimized and noise impact to remaining outputs is neglectable. Also, each output can be individually disabled by connecting the corresponding  $V_{DD}$  input to GND.

**Table 1. Selection Mode Table (continued)**

MODE	EN	S2	S1	S0	LVPECL <sup>(1)</sup>			LVC MOS
					Y0	Y1	Y2	Y3
26	1	1	1	V <sub>DD</sub> /2	÷ 1	÷ 8	÷ 8	÷ 4
27	1	1	1	1	÷ 1	Off (high-z)	÷ 16	÷ 4
28	V <sub>DD</sub> /2	0	0	0	÷ 1	÷ 1	÷ 16	÷ 4
29	V <sub>DD</sub> /2	0	0	V <sub>DD</sub> /2	÷ 1	÷ 2	÷ 16	÷ 4
30	V <sub>DD</sub> /2	0	0	1	÷ 1	÷ 4	÷ 16	÷ 4
31	V <sub>DD</sub> /2	0	V <sub>DD</sub> /2	0	÷ 1	÷ 8	÷ 16	÷ 4
32	V <sub>DD</sub> /2	0	V <sub>DD</sub> /2	V <sub>DD</sub> /2	÷ 1	Off (high-z)	Off (high-z)	÷ 1
33	V <sub>DD</sub> /2	0	V <sub>DD</sub> /2	1	÷ 1	÷ 1	Off (high-z)	÷ 1
34	V <sub>DD</sub> /2	0	1	0	÷ 1	÷ 2	Off (high-z)	÷ 1
35	V <sub>DD</sub> /2	0	1	V <sub>DD</sub> /2	÷ 1	÷ 1	Off (high-z)	÷ 2
36	V <sub>DD</sub> /2	0	1	1	÷ 1	÷ 2	Off (high-z)	÷ 2
37	V <sub>DD</sub> /2	V <sub>DD</sub> /2	0	0	÷ 1	Off (high-z)	Off (high-z)	÷ 2
38	V <sub>DD</sub> /2	V <sub>DD</sub> /2	0	V <sub>DD</sub> /2	÷ 1	÷ 1	÷ 1	÷ 2
39	V <sub>DD</sub> /2	V <sub>DD</sub> /2	0	1	÷ 1	÷ 2	÷ 8	÷ 2
40	V <sub>DD</sub> /2	V <sub>DD</sub> /2	V <sub>DD</sub> /2	0	÷ 1	÷ 2	÷ 8	÷ 8
41	V <sub>DD</sub> /2	V <sub>DD</sub> /2	V <sub>DD</sub> /2	V <sub>DD</sub> /2	÷ 1	÷ 4	Off (high-z)	÷ 1
42	V <sub>DD</sub> /2	V <sub>DD</sub> /2	V <sub>DD</sub> /2	1	÷ 1	÷ 8	Off (high-z)	÷ 1
43	V <sub>DD</sub> /2	V <sub>DD</sub> /2	1	0	÷ 1	÷ 4	Off (high-z)	÷ 2
44	V <sub>DD</sub> /2	V <sub>DD</sub> /2	1	V <sub>DD</sub> /2	÷ 1	÷ 8	Off (high-z)	÷ 2
45	V <sub>DD</sub> /2	V <sub>DD</sub> /2	1	1	÷ 1	÷ 1	÷ 2	÷ 2
46	V <sub>DD</sub> /2	1	0	0	÷ 1	Off (high-z)	Off (high-z)	÷ 8
47	V <sub>DD</sub> /2	1	0	V <sub>DD</sub> /2	÷ 1	÷ 4	Off (high-z)	÷ 8
48	V <sub>DD</sub> /2	1	0	1	÷ 1	÷ 4	÷ 8	÷ 8
49	V <sub>DD</sub> /2	1	V <sub>DD</sub> /2	0	÷ 1	÷ 8	Off (high-z)	÷ 8
50	V <sub>DD</sub> /2	1	V <sub>DD</sub> /2	V <sub>DD</sub> /2	÷ 1	÷ 2	÷ 8	÷ 16
Rsv	V <sub>DD</sub> /2	1	V <sub>DD</sub> /2	1	Reserved	Reserved	Reserved	Reserved
Rsv	V <sub>DD</sub> /2	1	1	0	N/A	Low	Low	Low
53	V <sub>DD</sub> /2	1	1	V <sub>DD</sub> /2	÷ 1	÷ 1	÷ 1	÷ 1
54	V <sub>DD</sub> /2	1	1	1	÷ 1	÷ 1	÷ 1	÷ 1

## ABSOLUTE MAXIMUM RATINGS

over operating free-air temperature (unless otherwise noted)<sup>(1)</sup>

V <sub>DD</sub>	Supply voltage	–0.3 V to 3.8 V
V <sub>I</sub>	Input voltage	–0.2 V to (V <sub>DD</sub> + 0.2 V)
V <sub>O</sub>	Output voltage	–0.2 V to (V <sub>DD</sub> + 0.2 V)
	Differential short-circuit current, Y <sub>n</sub> , $\overline{Y}_n$ , I <sub>OSD</sub>	Continuous
	Electrostatic discharge (HBM 1.5 kΩ, 100 pF), ESD	>2000 V
	Moisture level 24-terminal QFN package (solder reflow temperature of 235°C) MSL	2
T <sub>stg</sub>	Storage temperature	–65°C to 150°C
T <sub>J</sub>	Maximum junction temperature	125°C

(1) Stresses beyond those listed under "absolute maximum ratings" may cause permanent damage to the device. These are stress ratings only, and functional operation of the device at these or any other conditions beyond those indicated under "recommended operating conditions" is not implied. Exposure to absolute-maximum-rated conditions for extended periods may affect device reliability.

## RECOMMENDED OPERATING CONDITIONS

		MIN	TYP	MAX	UNIT
$V_{DD}$	Supply voltage	3	3.3	3.6	V
$T_A$	Operating free-air temperature	-40		85	°C

## ELECTRICAL CHARACTERISTICS

over recommended operating free-air temperature range (unless otherwise noted)

### LVPECL INPUT IN, $\overline{IN}$

PARAMETER		TEST CONDITIONS	MIN	TYP	MAX	UNIT
$f_{clk}$	Input frequency		0		800	MHz
$V_{CM}$	High-level input common mode		1		$V_{DD} - 0.3$	V
$V_{IN}$	Input voltage swing between IN and $\overline{IN}^{(1)}$		500		1300	mV
	Input voltage swing between IN and $\overline{IN}^{(2)}$		150		1300	
$I_{IN}$	Input current	$V_I = V_{DD}$ or 0 V			$\pm 10$	$\mu A$
$R_{IN}$	Input impedance		300			k $\Omega$
$C_I$	Input capacitance at IN, $\overline{IN}$			1		pF

(1) Is required to maintain ac specifications

(2) Is required to maintain device functionality

### LVPECL OUTPUT DRIVER Y[2:0], $\overline{Y}[2:0]$

PARAMETER		TEST CONDITIONS	MIN	TYP	MAX	UNIT
$f_{clk}$	Output frequency, see <a href="#">Figure 4</a>		0		800	MHz
$V_{OH}$	High-level output voltage	Termination with 50 $\Omega$ to $V_{DD} - 2$ V	$V_{DD} - 1.18$		$V_{DD} - 0.81$	V
$V_{OL}$	Low-level output voltage	Termination with 50 $\Omega$ to $V_{DD} - 2$ V	$V_{DD} - 1.98$		$V_{DD} - 1.55$	V
$V_O$	Output voltage swing between Y and $\overline{Y}$ , see <a href="#">Figure 4</a> .	Termination with 50 $\Omega$ to $V_{DD} - 2$ V	500			mV
$I_{OZL}$ $I_{OZH}$	Output 3-state current	$V_{DD} = 3.6$ V, $V_O = 0$ V			5	$\mu A$
		$V_{DD} = 3.6$ V, $V_O = V_{DD} - 0.8$ V			10	
$t_r/t_f$	Rise and fall time	20% to 80% of $V_{OUTPP}$ , see <a href="#">Figure 9</a> .	200		350	ps
$t_{skpecl(o)}$	Output skew between any LVPECL output Y[2:0] and $\overline{Y}[2:0]$	See Note A in <a href="#">Figure 8</a> .		15	30	ps
$t_{Duty}$	Output duty-cycle distortion <sup>(1)</sup>	Crossing point-to-crossing point distortion	-50		50	ps
$t_{sk(pp)}$	Part-to-part skew	Any Y, see Note B in <a href="#">Figure 8</a> .		50		ps
$C_O$	Output capacitance	$V_O = V_{DD}$ or GND		1		pF
LOAD	Expected output load			50		$\Omega$

(1) For an 800-MHz signal, the 50-ps error would result in a duty-cycle distortion of  $\pm 4\%$  when driven by an ideal clock input signal.

### LVPECL INPUT-TO-LVPECL OUTPUT PARAMETERS

PARAMETER		TEST CONDITIONS	MIN	TYP	MAX	UNIT
<b>LVPECL INPUT-TO-LVPECL OUTPUT PARAMETER</b>						
$t_{pd(lh)}$	Propagation delay rising edge	VOX to VOX	320		600	ps
$t_{pd(hl)}$	Propagation delay falling edge	VOX to VOX	320		600	ps
$t_{sk(p)}$	LVPECL pulse skew	VOX to VOX, see Note C in <a href="#">Figure 8</a> .			100	ps

**LVC MOS OUTPUT PARAMETER, Y3**

PARAMETER		TEST CONDITIONS		MIN	TYP	MAX	UNIT
$f_{clk}$	OUTPUT frequency, see Figure 5 <sup>(1)</sup> .			0		200	MHz
$t_{skLVCMOS(o)}$	Output skew between the LVC MOS output Y3 and LVPECL outputs Y[2:0]	VOX to $V_{DD}/2$ , see Figure 8.		1.3	1.6	2.1	ns
$t_{sk(pp)}$	Part-to-part skew	Y3, see Note B in Figure 8.			300		ps
$V_{OH}$	High-level output voltage	$V_{DD} = \text{min to max}$	$I_{OH} = -100 \mu\text{A}$	$V_{DD} - 0.1$			V
		$V_{DD} = 3 \text{ V}$	$I_{OH} = -6 \text{ mA}$	2.4			
		$V_{DD} = 3 \text{ V}$	$I_{OH} = -12 \text{ mA}$	2			
$V_{OL}$	Low-level output voltage	$V_{DD} = \text{min to max}$	$I_{OL} = 100 \mu\text{A}$			0.1	V
		$V_{DD} = 3 \text{ V}$	$I_{OL} = 6 \text{ mA}$			0.5	
		$V_{DD} = 3 \text{ V}$	$I_{OL} = 12 \text{ mA}$			0.8	
$I_{OH}$	High-level output current	$V_{DD} = 3.3 \text{ V}$	$V_O = 1.65 \text{ V}$		-29		mA
$I_{OL}$	Low-level output current	$V_{DD} = 3.3 \text{ V}$	$V_O = 1.65 \text{ V}$		37		mA
$I_{OZ}$	High-impedance-state output current	$V_{DD} = 3.6 \text{ V}$	$V_O = V_{DD} \text{ or } 0 \text{ V}$			±5	μA
$C_O$	Output capacitance	$V_{DD} = 3.3 \text{ V}$			2		pF
$t_{Duty}$	Output duty cycle distortion <sup>(2)</sup>	Measured at $V_{DD}/2$		-150		150	ps
$t_{pd(lh)}$	Propagation delay rising edge from IN to Y3	VOX to $V_{DD}/2$ load, see Figure 10.		1.6		2.6	ns
$t_{pd(hl)}$	Propagation delay falling edge from IN to Y3	VOX to $V_{DD}/2$ load, see Figure 10.		1.6		2.6	ns
$t_r$	Output rise slew rate	20% to 80% of swing, see Figure 10.		1.4	2.3		V/ns
$t_f$	Output fall slew rate	80% to 20% of swing, see Figure 10.		1.4	2.3		V/ns

- (1) Operating the CDCM1804 LVC MOS output above the maximum frequency does not cause a malfunction to the device, but the Y3 output will not achieve enough signal swing to meet the output specification. Therefore, the CDCM1804 can be operated at higher frequencies, while the LVC MOS output Y3 becomes unusable.
- (2) For a 200-MHz signal, the 150-ps error would result in a duty cycle distortion of ±3% when driven by an ideal clock input signal.

**JITTER CHARACTERISTICS**

PARAMETER		TEST CONDITIONS		MIN	TYP	MAX	UNIT
$t_{jitterLVPECL}$	Additive phase jitter from input to LVPECL output Y[2:0], see Figure 2.	12 kHz to 20 MHz, $f_{out} = 250 \text{ MHz to } 800 \text{ MHz}$ , divide-by-1 mode				0.15	ps rms
		50 kHz to 40 MHz, $f_{out} = 250 \text{ MHz to } 800 \text{ MHz}$ , divide-by-1 mode				0.25	
$t_{jitterLVCMOS}$	Additive phase jitter from input to LVC MOS output Y3, see Figure 3.	12 kHz to 20 MHz, $f_{out} = 250 \text{ MHz}$ , divide-by-1 mode				0.25	ps rms
		50 kHz to 40 MHz, $f_{out} = 250 \text{ MHz}$ , divide-by-1 mode				0.4	

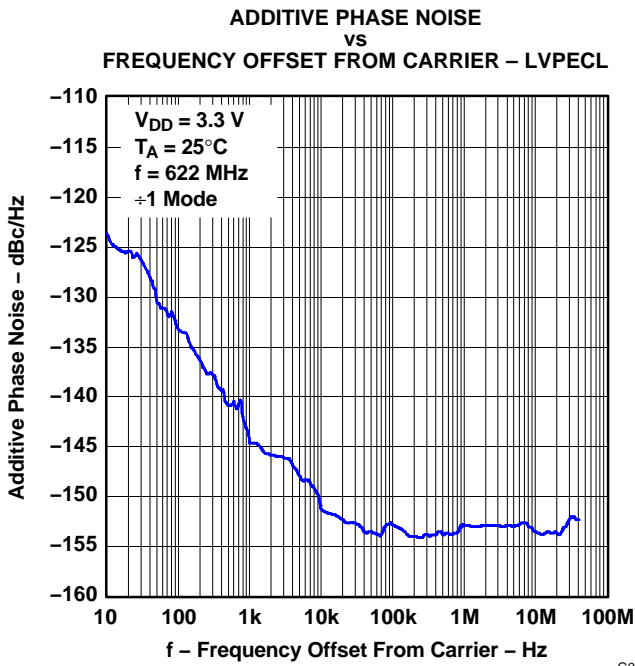

Figure 2.

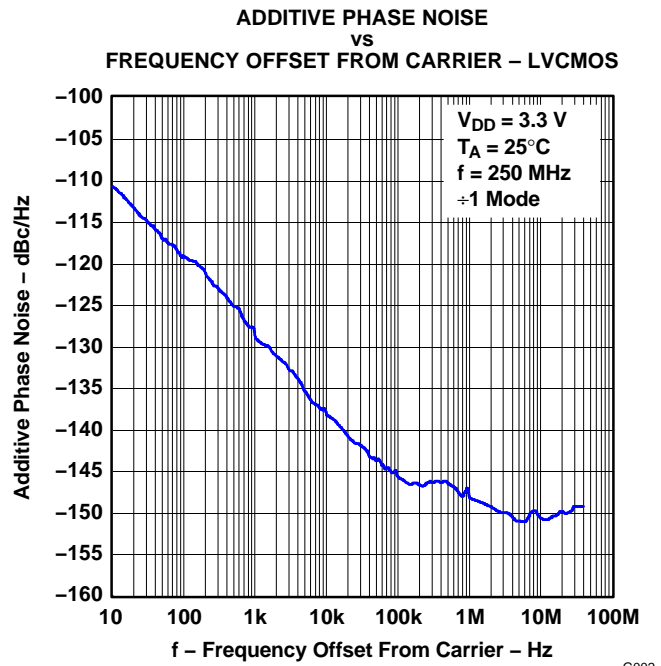

Figure 3.

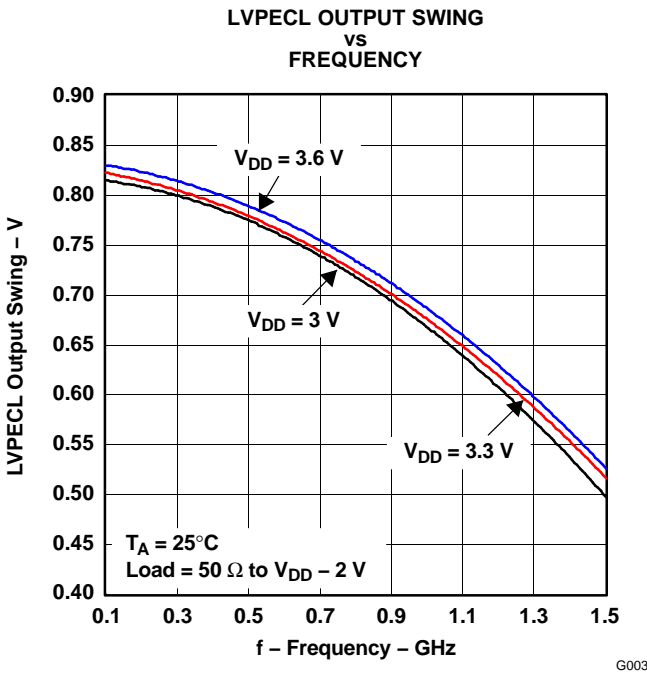

Figure 4.

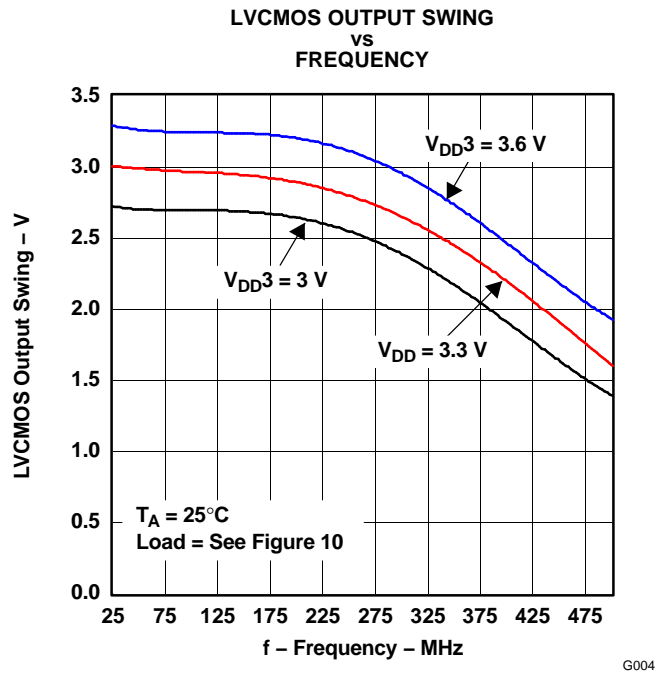

Figure 5.

## SUPPLY CURRENT ELECTRICAL CHARACTERISTICS

over recommended operating free-air temperature range (unless otherwise noted)

PARAMETER		TEST CONDITIONS	MIN	TYP	MAX	UNIT
$I_{DD}$	Supply current	Full load		160		mA
		No load			110	
	Supply current saving per LVPECL output stage disabled, no load	$f = 800$ MHz for LVPECL output, $V_{DD} = 3.3$ V		10		mA
$I_{DDZ}$	Supply current, 3-state	All outputs in the high-impedance state by control logic, $f = 0$ Hz, $V_{DD} = 3.6$ V			0.5	mA

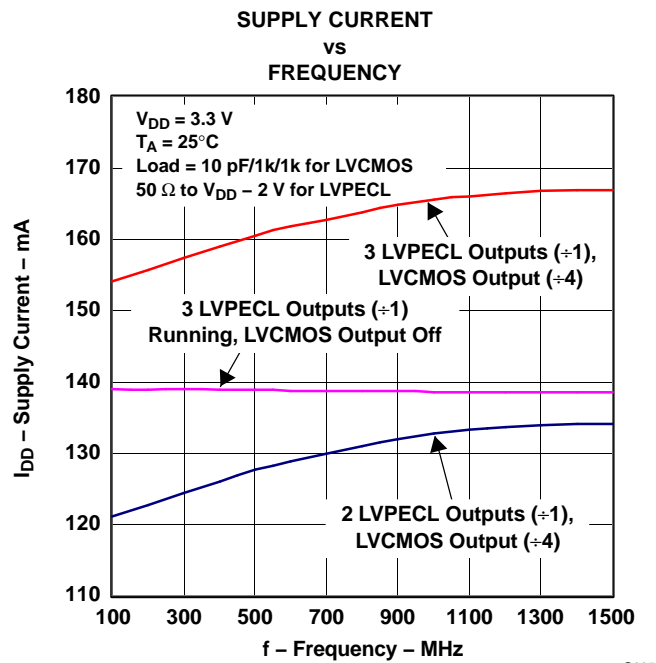

Figure 6.

## PACKAGE THERMAL RESISTANCE

PARAMETER		TEST CONDITIONS	MIN	TYP	MAX	UNIT
$R_{\theta JA-1}$	QFN-24 package thermal resistance <sup>(1)</sup>	4-layer JEDEC test board (JESD51-7), airflow = 0 ft/min		106.6		°C/W
$R_{\theta JA-2}$	QFN-24 package thermal resistance with thermal vias in PCB <sup>(1)</sup>	4-layer JEDEC test board (JESD51-7) with four thermal vias of 22-mil diameter each, airflow = 0 ft/min		55.4		°C/W

- (1) It is recommended to provide four thermal vias to connect the thermal pad of the package effectively with the PCB and ensure a good heat sink.

### Example:

#### Calculation of the junction-lead temperature with a 4-layer JEDEC test board using four thermal vias:

$$T_{\text{Chassis}} = 85^{\circ}\text{C} \text{ (temperature of the chassis)}$$

$$P_{\text{effective}} = I_{\text{max}} \times V_{\text{max}} = 110 \text{ mA} \times 3.6 \text{ V} = 396 \text{ mW} \text{ (maximum power consumption inside the package)}$$

$$\theta T_{\text{Junction}} = R_{\theta JA-2} \times P_{\text{effective}} = 55.45^{\circ}\text{C/W} \times 396 \text{ mW} = 21.96^{\circ}\text{C}$$

$$T_{\text{Junction}} = \theta T_{\text{Junction}} + T_{\text{Chassis}} = 21.96^{\circ}\text{C} + 85^{\circ}\text{C} = 107^{\circ}\text{C} \text{ (the maximum junction temperature of)}$$

$$T_{\text{die-max}} = 125^{\circ}\text{C} \text{ is not violated}$$

## CONTROL INPUT CHARACTERISTICS

over recommended operating free-air temperature range

PARAMETER		TEST CONDITIONS	MIN	TYP	MAX	UNIT
$t_{\text{su}}$	Setup time, S0, S1, S2, and EN terminals before clock IN		25			ns
$t_{\text{h}}$	Hold time, S0, S1, S2, and EN terminals after clock IN		0			ns
$t_{\text{(disable)}}$	Time between latching the EN low transition and when all outputs are disabled (how much time is required until the outputs turn off)			10		ns
$t_{\text{(enable)}}$	Time between latching the EN low-to-high transition and when outputs are enabled based on control settings (how much time passes before the outputs carry valid signals)			1		μs
$R_{\text{pullup}}$	Internal pullup resistor on S[2:0] and EN inputs		42	60	78	kΩ
$V_{\text{IH(H)}}$	Three-level input high, S0, S1, S2, and EN terminals <sup>(1)</sup>		0.9 $V_{\text{DD}}$			V
$V_{\text{IM(M)}}$	Three-level input MID, S0, S1, S2, and EN terminals		0.3 $V_{\text{DD}}$		0.7 $V_{\text{DD}}$	V
$V_{\text{IL(L)}}$	Three-level input low, S0, S1, S2, and EN terminals				0.1 $V_{\text{DD}}$	V
$I_{\text{IH}}$	Input current, S0, S1, S2, and EN terminals	$V_{\text{I}} = V_{\text{DD}}$			–5	μA
$I_{\text{IL}}$		$V_{\text{I}} = \text{GND}$	38		85	μA

- (1) Leaving this terminal floating automatically pulls the logic level high to  $V_{\text{DD}}$  through an internal pullup resistor of 60 kΩ.

## BIAS VOLTAGE VBB

over recommended operating free-air temperature range

PARAMETER	TEST CONDITIONS	MIN	TYP	MAX	UNIT	
VBB	Output reference voltage	$V_{\text{DD}} = 3 \text{ V} - 3.6 \text{ V}$ , $I_{\text{BB}} = -0.2 \text{ mA}$	$V_{\text{DD}} - 1.4$		$V_{\text{DD}} - 1.2$	V

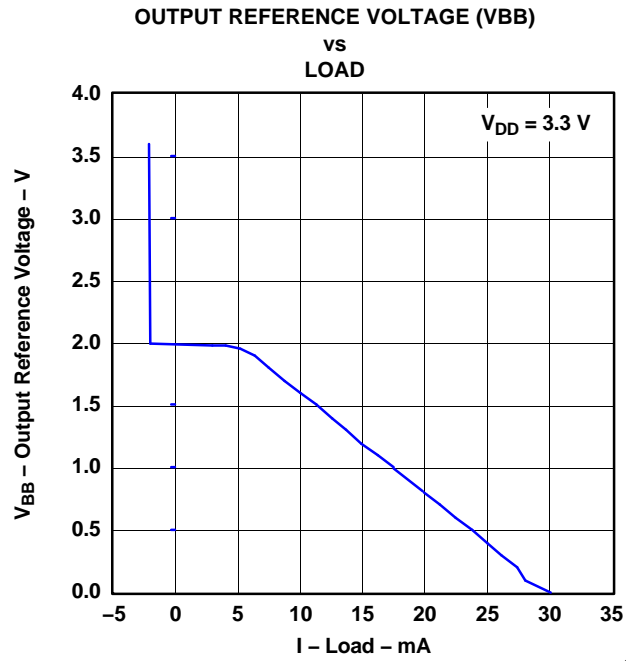

G006

Figure 7.

PARAMETER MEASUREMENT INFORMATION

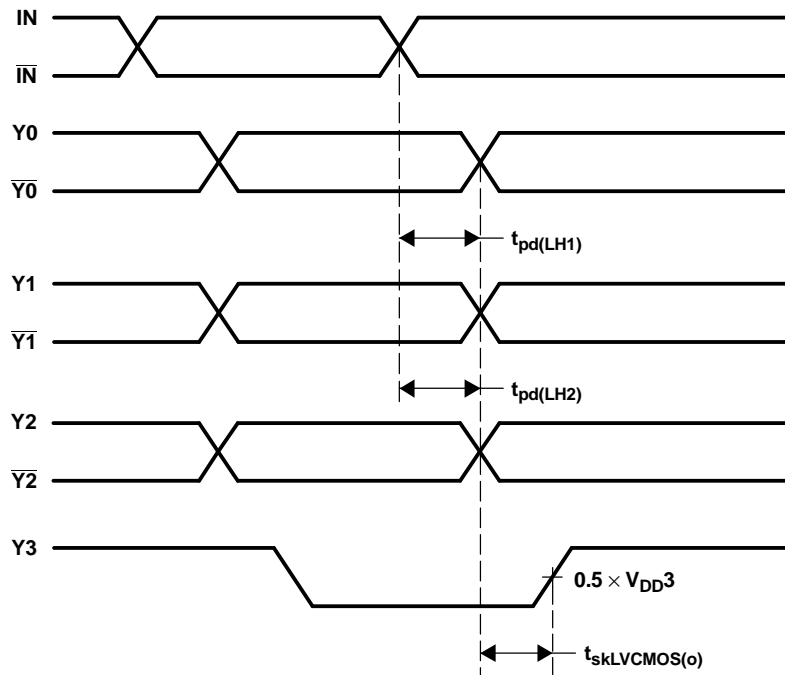

- NOTES: A. Output skew,  $t_{sk(o)}$ , is calculated as the greater of:
- The difference between the fastest and the slowest  $t_{pd(LH)n}$  ( $n = 0 \dots 2$ )
  - The difference between the fastest and the slowest  $t_{pd(HL)n}$  ( $n = 0 \dots 2$ )
- B. Part-to-part skew,  $t_{sk(pp)}$ , is calculated as the greater of:
- The difference between the fastest and the slowest  $t_{pd(LH)n}$  ( $n = 0 \dots 2$  for LVPECL,  $n = 3$  for LVCMS) across multiple devices
  - The difference between the fastest and the slowest  $t_{pd(HL)n}$  ( $n = 0 \dots 2$  for LVPECL,  $n = 3$  for LVCMS) across multiple devices
- C. Pulse skew,  $t_{sk(p)}$ , is calculated as the magnitude of the absolute time difference between the high-to-low ( $t_{pd(HL)}$ ) and the low-to-high ( $t_{pd(LH)}$ ) propagation delays when a single switching input causes one or more outputs to switch,  $t_{sk(p)} = |t_{pd(HL)} - t_{pd(LH)}|$ . Pulse skew is sometimes referred to as *pulse width distortion* or *duty cycle skew*.

T0067-01

Figure 8. Waveforms for Calculation of  $t_{sk(o)}$  and  $t_{sk(pp)}$

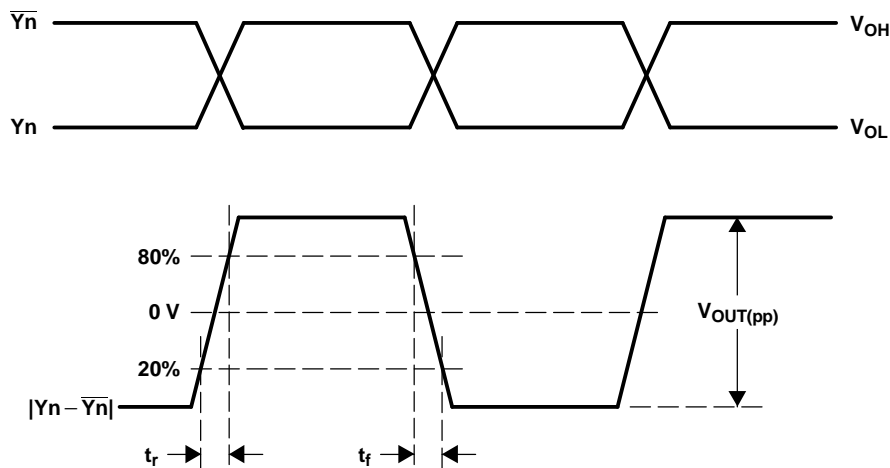

T0058-02

Figure 9. LVPECL Differential Output Voltage and Rise/Fall Time

**PARAMETER MEASUREMENT INFORMATION (continued)**

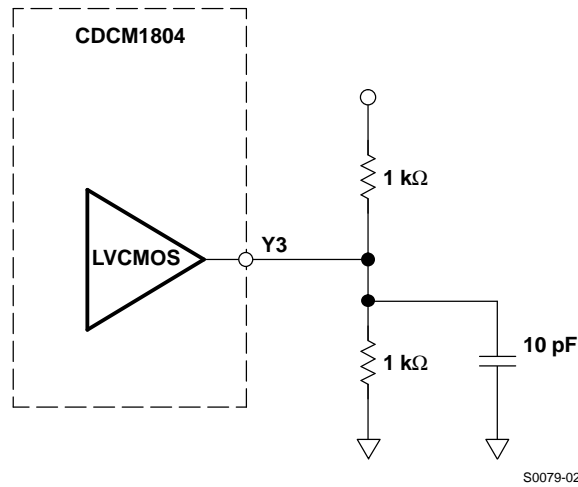

**Figure 10. LVC MOS Output Loading During Device Test**

**PCB DESIGN FOR THERMAL FUNCTIONALITY**

It is recommended to take special care of the PCB design for good thermal flow from the QFN-24 terminal package to the PCB.

Due to the three LVPECL outputs, the current consumption of the CDCM1804 is fixed.

JEDEC JESD51-7 specifies thermal conductivity for standard PCB boards.

Modeling the CDCM1804 with a standard 4-layer JEDEC board results in a 67.22°C maximum temperature with  $R_{\theta JA}$  of 106.62°C/W for 25°C ambient temperature.

When deploying four thermal vias (one per quadrant), the thermal flow improves significantly, yielding 46.94°C maximum temperature with  $R_{\theta JA}$  of 55.4°C/W for 25°C ambient temperature.

To ensure sufficient thermal flow, it is recommended to design with four thermal vias in applications enabling all four outputs at once.

**PARAMETER MEASUREMENT INFORMATION (continued)**

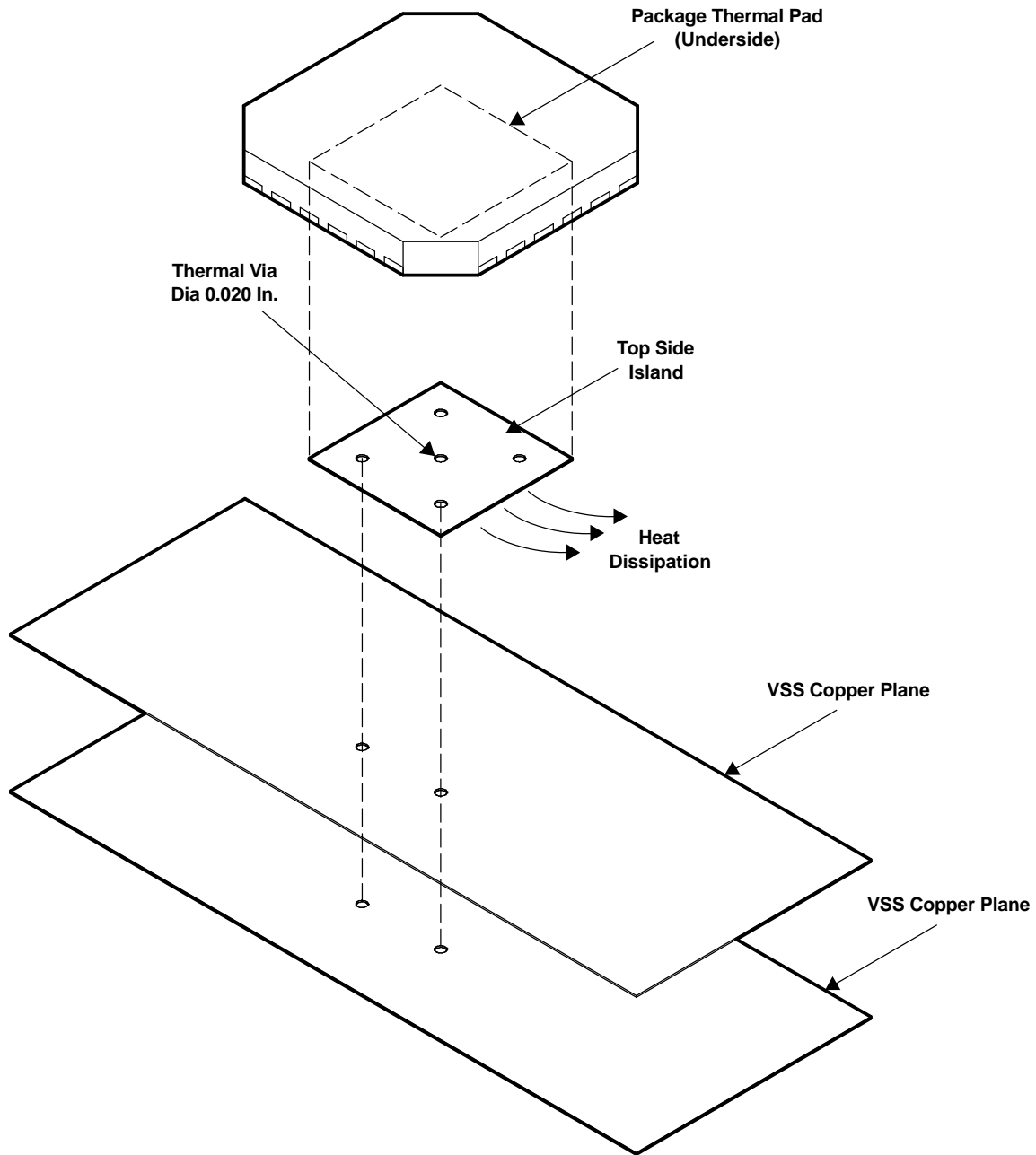

M0029-01

**Figure 11. Recommended Thermal Via Placement**

See the application reports *Quad Flatpack No-Lead Logic Packages (SCBA017)* and *QFN/SOP PCB Attachment (SLUA271)* for further package-related information.

## APPLICATION INFORMATION

### LVPECL RECEIVER INPUT TERMINATION

The input of the CDCM1804 has a high impedance and comes with a large common-mode voltage range.

For optimized noise performance, it is recommended to properly terminate the PCB trace (transmission line). If a differential signal drives the CDCM1804, then a 100- $\Omega$  termination resistor is recommended to be placed as close as possible across the input terminals. An even better approach is to install  $2 \times 50 \Omega$ , with the center tap connected to a capacitor (C) to terminate odd-mode noise and make up for transmission-line mismatches. The VBB output can also be connected to the center tap to bias the input signal to ( $V_{DD} - 1.3 \text{ V}$ ) (see [Figure 12](#)).

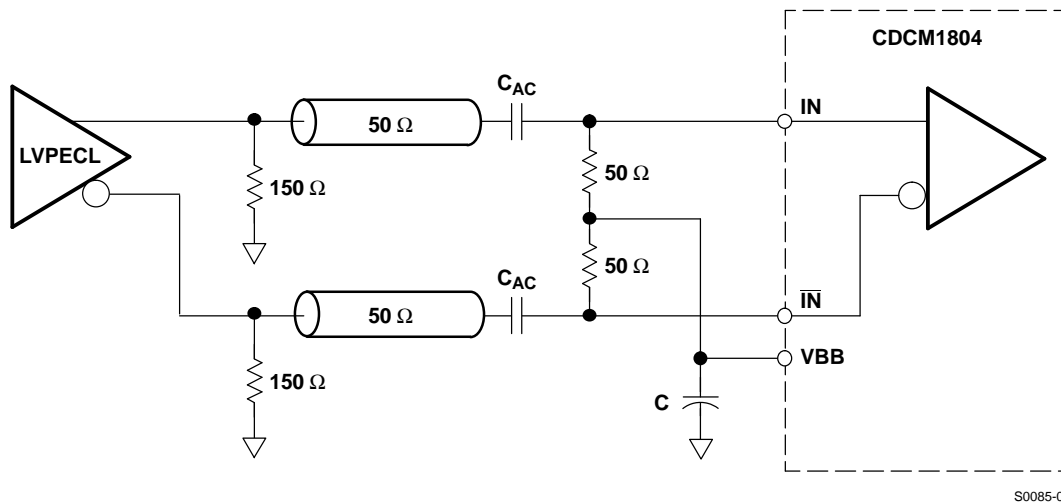

Figure 12. Recommended AC-Coupling LVPECL Receiver Input Termination

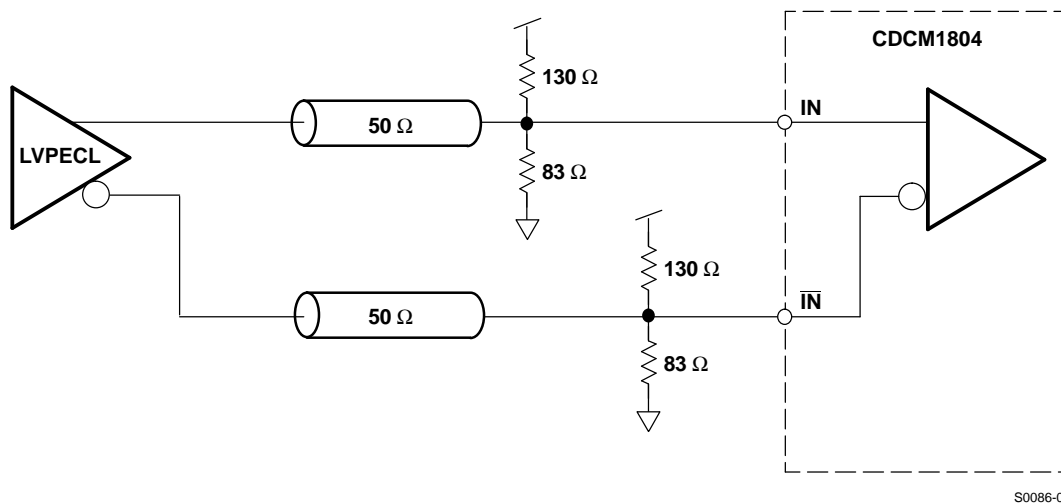
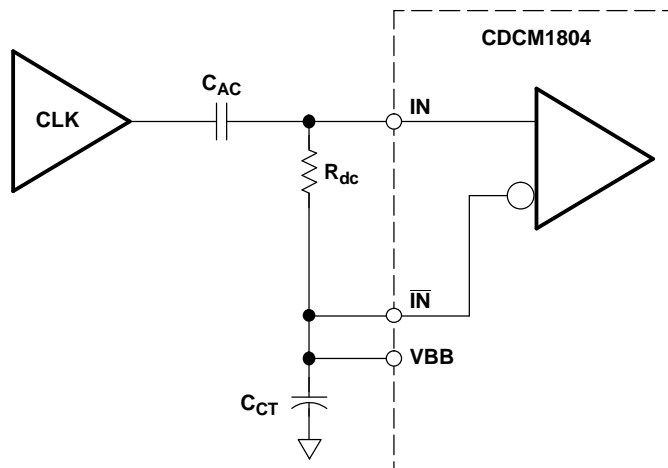

Figure 13. Recommended DC-Coupling LVPECL Receiver Input Termination

The CDCM1804 can also be driven by single-ended signals. Typically, the input signal becomes connected to one input, while the complementary input must be properly biased to the center voltage of the incoming input signal. For LVCMOS signals, this would be  $V_{CC}/2$ , realized by a simple voltage divider (e.g., two 10-k $\Omega$  resistors). The best option (especially if the dc offset of the input signal might vary) is to ac-couple the input signal and then rebias the signal using the VBB reference output. See [Figure 14](#).

## APPLICATION INFORMATION (continued)



NOTE:  $C_{AC}$  – AC-coupling capacitor (e.g., 10 nF)  
 $C_{CT}$  – Capacitor keeps voltage at  $\overline{IN}$  constant (e.g., 10 nF)  
 $R_{dc}$  – Load and correct duty cycle (e.g., 50  $\Omega$ )  
VBB – Bias voltage output

S0087-01

**Figure 14. Typical Application Setting for Single-Ended Input Signals Driving the CDCM1804**

## DEVICE BEHAVIOR DURING RESET AND CONTROL-TERMINAL SWITCHING

Output Behavior From Enabling the Device ( $EN = 0 \rightarrow 1$ )

In disable mode ( $EN = 0$ ), all output drivers are switched in high-Z mode. The S[2:0] control inputs are also switched off. In the same mode, all flip-flops are reset. The typical current consumption is below 500  $\mu A$ .

When the device is enabled again, it takes typically 1  $\mu s$  for the settling of the reference voltage and currents. During this time, the outputs Y[2:0] and  $\overline{Y}$ [2:0] drive a high signal. Y3 is unknown (could be high or low). After the settle time, the outputs go into the low state. Due to the synchronization of each output driver signal with the input clock, the state of the waveforms after enabling the device is as shown in [Figure 15](#). The inverting input and output signal are not included. The Y:/1 waveform is the undivided output driver state.

**APPLICATION INFORMATION (continued)**

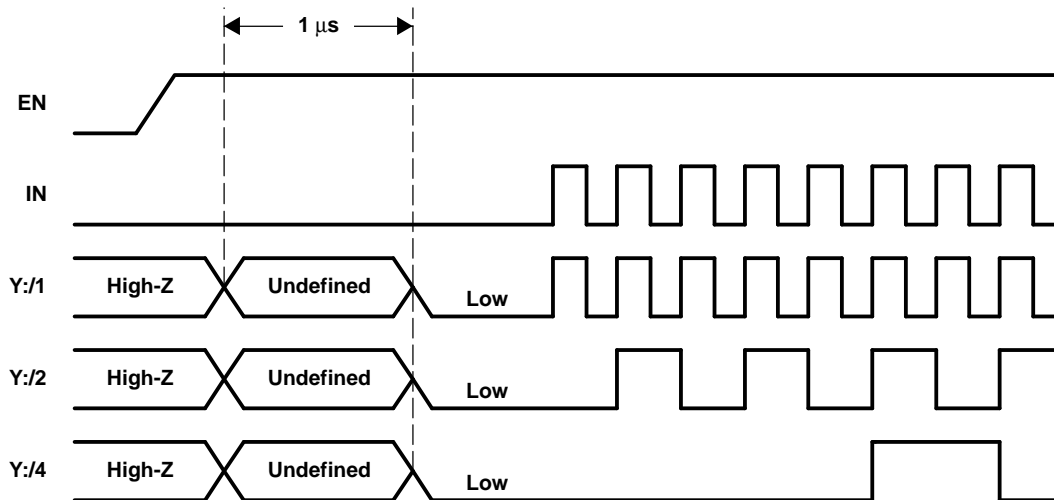

Signal State After the Device is Enabled (IN = Low)

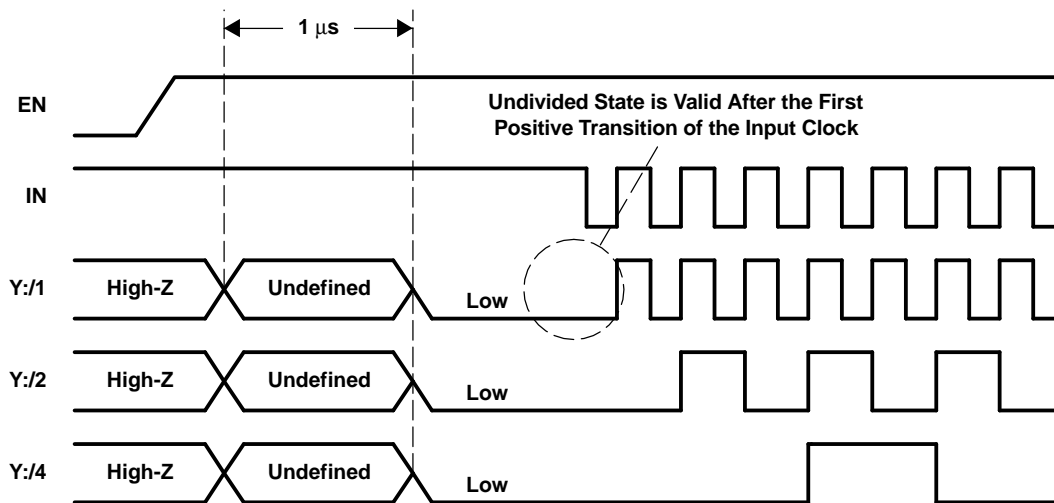

Signal State After the Device is Enabled (IN = High)

T0068-01

**Figure 15. Waveforms**

**Enabling a Single Output Stage**

If a single output stage becomes enabled:

- Y[2:0] is either low or high (undefined).
- $\bar{Y}[2:0]$  is the inverted signal of Y[2:0].

With the first positive clock transition, the undivided output becomes the input clock state. The divided output states are equal to the actual internal divider. The internal divider is not reset while enabling single-output drivers.

APPLICATION INFORMATION (continued)

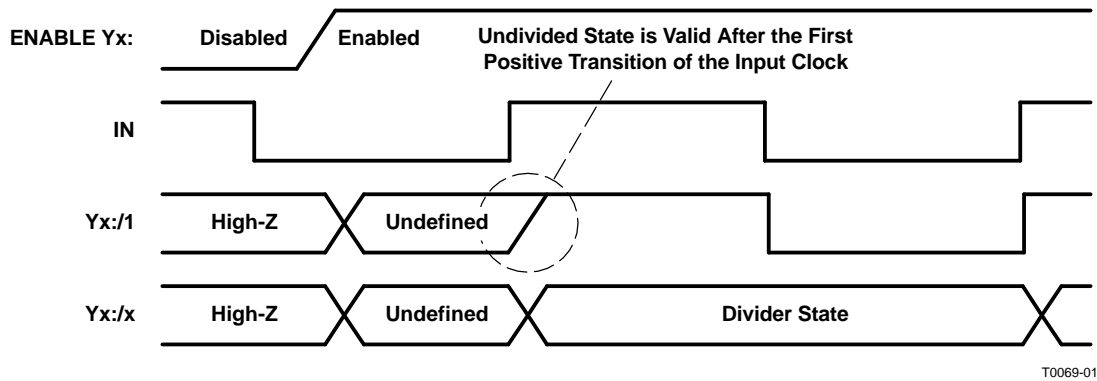

Figure 16. Signal State After an Output Driver Becomes Enabled While IN = 0

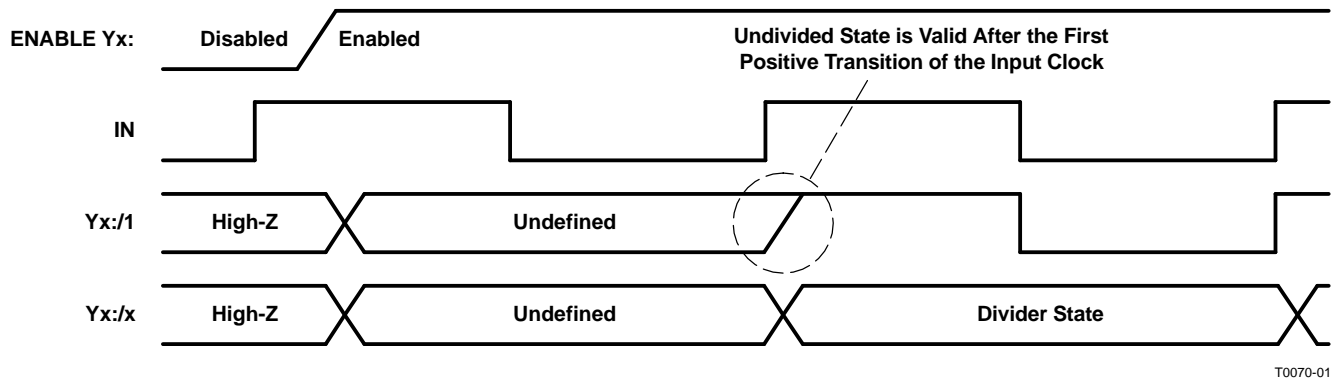

Figure 17. Signal State After an Output Driver Becomes Enabled While IN = 1

**PACKAGING INFORMATION**

Orderable Device	Status (1)	Package Type	Package Drawing	Pins	Package Qty	Eco Plan (2)	Lead/Ball Finish (6)	MSL Peak Temp (3)	Op Temp (°C)	Device Marking (4/5)	Samples
CDCM1804RGER	ACTIVE	VQFN	RGE	24	3000	Green (RoHS & no Sb/Br)	CU NIPDAU	Level-2-260C-1 YEAR	-40 to 85	CDCM 1804	<a href="#">Samples</a>
CDCM1804RGERG4	ACTIVE	VQFN	RGE	24	3000	Green (RoHS & no Sb/Br)	CU NIPDAU	Level-2-260C-1 YEAR	-40 to 85	CDCM 1804	<a href="#">Samples</a>
CDCM1804RGET	ACTIVE	VQFN	RGE	24	250	Green (RoHS & no Sb/Br)	CU NIPDAU	Level-2-260C-1 YEAR	-40 to 85	CDCM 1804	<a href="#">Samples</a>
CDCM1804RGETG4	ACTIVE	VQFN	RGE	24	250	Green (RoHS & no Sb/Br)	CU NIPDAU	Level-2-260C-1 YEAR	-40 to 85	CDCM 1804	<a href="#">Samples</a>
SN0305042RTHR	ACTIVE	VQFN	RGE	24	3000	Green (RoHS & no Sb/Br)	CU NIPDAU	Level-2-260C-1 YEAR	-40 to 85	CDCM 1804	<a href="#">Samples</a>
SN0305042RTHT	ACTIVE	VQFN	RGE	24	250	Green (RoHS & no Sb/Br)	CU NIPDAU	Level-2-260C-1 YEAR	-40 to 85	CDCM 1804	<a href="#">Samples</a>

(1) The marketing status values are defined as follows:

**ACTIVE:** Product device recommended for new designs.

**LIFEBUY:** TI has announced that the device will be discontinued, and a lifetime-buy period is in effect.

**NRND:** Not recommended for new designs. Device is in production to support existing customers, but TI does not recommend using this part in a new design.

**PREVIEW:** Device has been announced but is not in production. Samples may or may not be available.

**OBSOLETE:** TI has discontinued the production of the device.

(2) Eco Plan - The planned eco-friendly classification: Pb-Free (RoHS), Pb-Free (RoHS Exempt), or Green (RoHS & no Sb/Br) - please check <http://www.ti.com/productcontent> for the latest availability information and additional product content details.

**TBD:** The Pb-Free/Green conversion plan has not been defined.

**Pb-Free (RoHS):** TI's terms "Lead-Free" or "Pb-Free" mean semiconductor products that are compatible with the current RoHS requirements for all 6 substances, including the requirement that lead not exceed 0.1% by weight in homogeneous materials. Where designed to be soldered at high temperatures, TI Pb-Free products are suitable for use in specified lead-free processes.

**Pb-Free (RoHS Exempt):** This component has a RoHS exemption for either 1) lead-based flip-chip solder bumps used between the die and package, or 2) lead-based die adhesive used between the die and leadframe. The component is otherwise considered Pb-Free (RoHS compatible) as defined above.

**Green (RoHS & no Sb/Br):** TI defines "Green" to mean Pb-Free (RoHS compatible), and free of Bromine (Br) and Antimony (Sb) based flame retardants (Br or Sb do not exceed 0.1% by weight in homogeneous material)

(3) MSL, Peak Temp. - The Moisture Sensitivity Level rating according to the JEDEC industry standard classifications, and peak solder temperature.

(4) There may be additional marking, which relates to the logo, the lot trace code information, or the environmental category on the device.

(5) Multiple Device Markings will be inside parentheses. Only one Device Marking contained in parentheses and separated by a "~" will appear on a device. If a line is indented then it is a continuation of the previous line and the two combined represent the entire Device Marking for that device.

<sup>(6)</sup> Lead/Ball Finish - Orderable Devices may have multiple material finish options. Finish options are separated by a vertical ruled line. Lead/Ball Finish values may wrap to two lines if the finish value exceeds the maximum column width.

**Important Information and Disclaimer:** The information provided on this page represents TI's knowledge and belief as of the date that it is provided. TI bases its knowledge and belief on information provided by third parties, and makes no representation or warranty as to the accuracy of such information. Efforts are underway to better integrate information from third parties. TI has taken and continues to take reasonable steps to provide representative and accurate information but may not have conducted destructive testing or chemical analysis on incoming materials and chemicals. TI and TI suppliers consider certain information to be proprietary, and thus CAS numbers and other limited information may not be available for release.

In no event shall TI's liability arising out of such information exceed the total purchase price of the TI part(s) at issue in this document sold by TI to Customer on an annual basis.

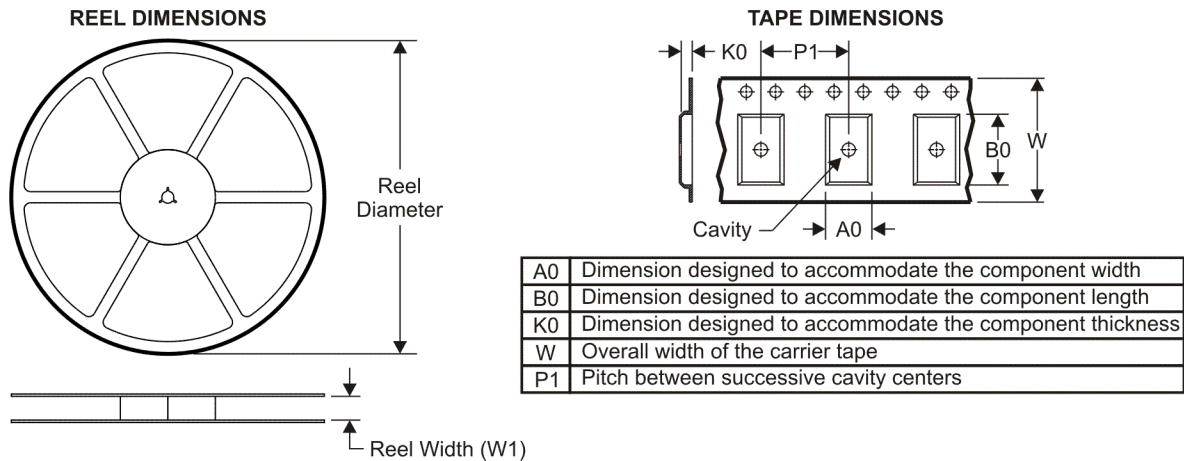
**TAPE AND REEL INFORMATION**

**QUADRANT ASSIGNMENTS FOR PIN 1 ORIENTATION IN TAPE**

\*All dimensions are nominal

Device	Package Type	Package Drawing	Pins	SPQ	Reel Diameter (mm)	Reel Width W1 (mm)	A0 (mm)	B0 (mm)	K0 (mm)	P1 (mm)	W (mm)	Pin1 Quadrant
CDCM1804RGER	VQFN	RGE	24	3000	330.0	12.4	4.3	4.3	1.5	8.0	12.0	Q2
CDCM1804RGET	VQFN	RGE	24	250	330.0	12.4	4.3	4.3	1.5	8.0	12.0	Q2

**TAPE AND REEL BOX DIMENSIONS**

\*All dimensions are nominal

Device	Package Type	Package Drawing	Pins	SPQ	Length (mm)	Width (mm)	Height (mm)
CDCM1804RGER	VQFN	RGE	24	3000	340.5	338.1	20.6
CDCM1804RGET	VQFN	RGE	24	250	340.5	338.1	20.6

RGE (S-PVQFN-N24)

PLASTIC QUAD FLATPACK NO-LEAD

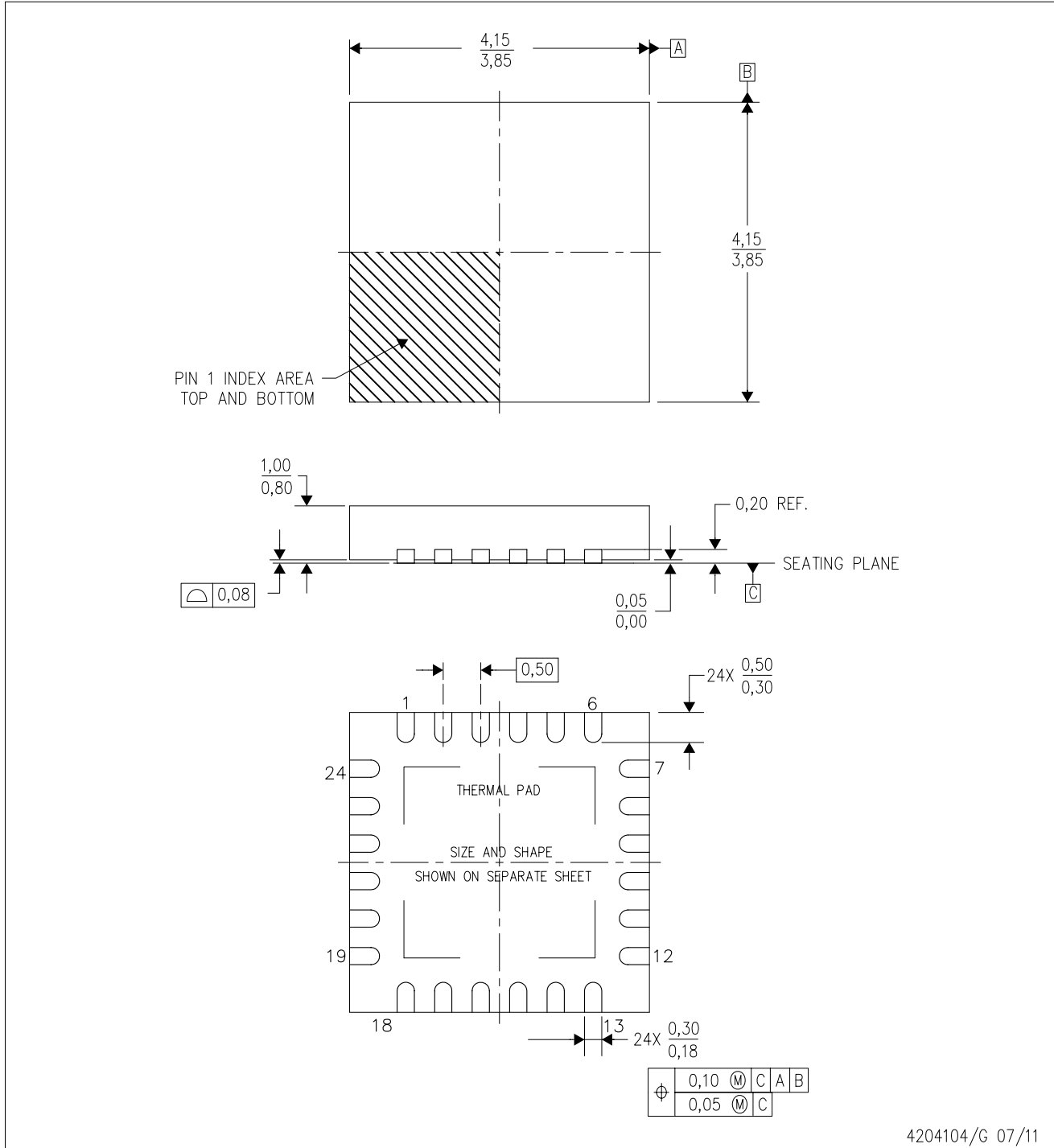

4204104/G 07/11

- NOTES:
- All linear dimensions are in millimeters. Dimensioning and tolerancing per ASME Y14.5M-1994.
  - This drawing is subject to change without notice.
  - Quad Flatpack, No-Leads (QFN) package configuration.
  - The package thermal pad must be soldered to the board for thermal and mechanical performance.
  - See the additional figure in the Product Data Sheet for details regarding the exposed thermal pad features and dimensions.
  - Falls within JEDEC MO-220.

# THERMAL PAD MECHANICAL DATA

RGE (S-PVQFN-N24)

PLASTIC QUAD FLATPACK NO-LEAD

## THERMAL INFORMATION

This package incorporates an exposed thermal pad that is designed to be attached directly to an external heatsink. The thermal pad must be soldered directly to the printed circuit board (PCB). After soldering, the PCB can be used as a heatsink. In addition, through the use of thermal vias, the thermal pad can be attached directly to the appropriate copper plane shown in the electrical schematic for the device, or alternatively, can be attached to a special heatsink structure designed into the PCB. This design optimizes the heat transfer from the integrated circuit (IC).

For information on the Quad Flatpack No-Lead (QFN) package and its advantages, refer to Application Report, QFN/SON PCB Attachment, Texas Instruments Literature No. SLUA271. This document is available at [www.ti.com](http://www.ti.com).

The exposed thermal pad dimensions for this package are shown in the following illustration.

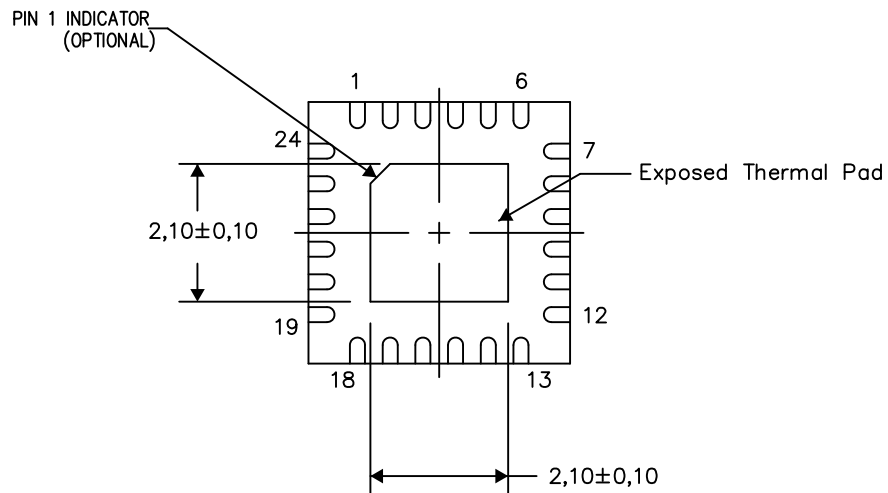

Bottom View

Exposed Thermal Pad Dimensions

4206344-7/AK 08/15

NOTES: A. All linear dimensions are in millimeters

RGE (S-PVQFN-N24)

PLASTIC QUAD FLATPACK NO-LEAD

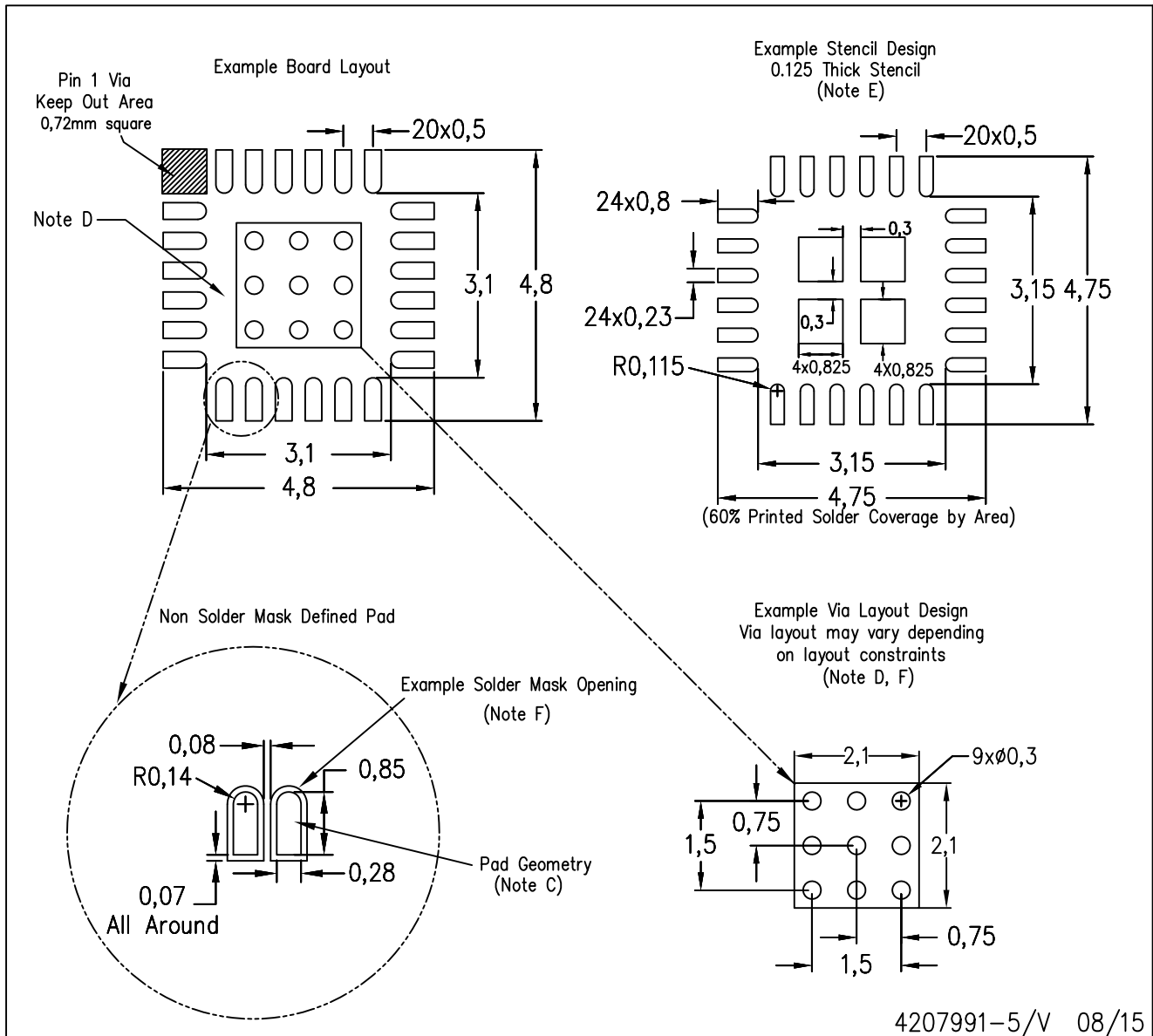

- NOTES:
- All linear dimensions are in millimeters.
  - This drawing is subject to change without notice.
  - Publication IPC-7351 is recommended for alternate designs.
  - This package is designed to be soldered to a thermal pad on the board. Refer to Application Note, Quad Flat-Pack Packages, Texas Instruments Literature No. SLUA271, and also the Product Data Sheets for specific thermal information, via requirements, and recommended board layout. These documents are available at [www.ti.com](http://www.ti.com) <<http://www.ti.com>>.
  - Laser cutting apertures with trapezoidal walls and also rounding corners will offer better paste release. Customers should contact their board assembly site for stencil design recommendations. Refer to IPC 7525 for stencil design considerations.
  - Customers should contact their board fabrication site for recommended solder mask tolerances and via tenting recommendations for vias placed in the thermal pad.

RTH (S-PVQFN-N24)

PLASTIC QUAD FLATPACK

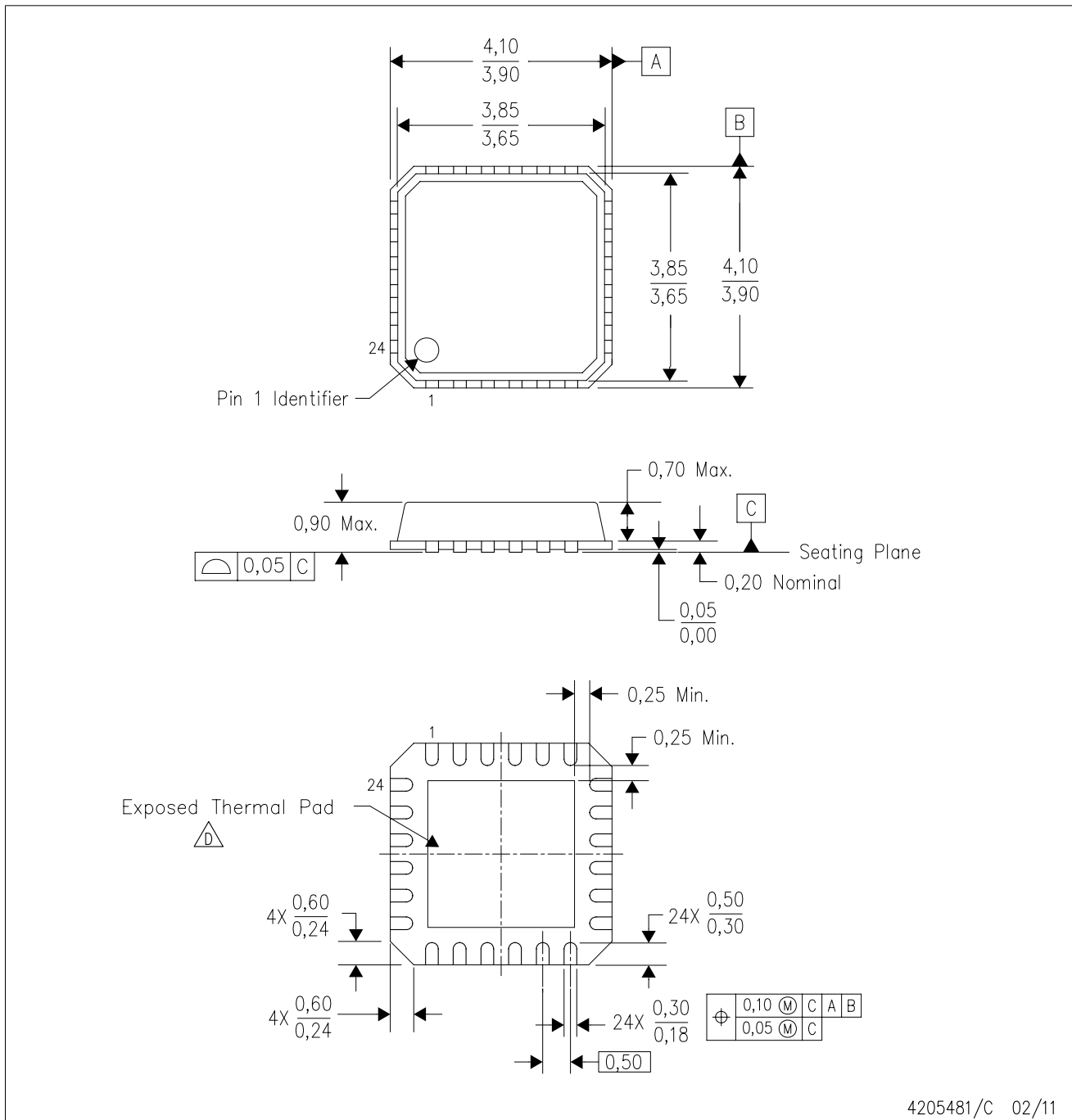

4205481/C 02/11

- NOTES:
- A. All linear dimensions are in millimeters. Dimensioning and tolerancing per ASME Y14.5M-1994.
  - B. This drawing is subject to change without notice.
  - C. QFN (Quad Flatpack No-Lead) Package configuration.
  -  D. The package thermal pad must be soldered to the board for thermal and mechanical performance. See the Product Data Sheet for details regarding the exposed thermal pad dimensions.

## IMPORTANT NOTICE

Texas Instruments Incorporated (TI) reserves the right to make corrections, enhancements, improvements and other changes to its semiconductor products and services per JESD46, latest issue, and to discontinue any product or service per JESD48, latest issue. Buyers should obtain the latest relevant information before placing orders and should verify that such information is current and complete.

TI's published terms of sale for semiconductor products (<http://www.ti.com/sc/docs/stdterms.htm>) apply to the sale of packaged integrated circuit products that TI has qualified and released to market. Additional terms may apply to the use or sale of other types of TI products and services.

Reproduction of significant portions of TI information in TI data sheets is permissible only if reproduction is without alteration and is accompanied by all associated warranties, conditions, limitations, and notices. TI is not responsible or liable for such reproduced documentation. Information of third parties may be subject to additional restrictions. Resale of TI products or services with statements different from or beyond the parameters stated by TI for that product or service voids all express and any implied warranties for the associated TI product or service and is an unfair and deceptive business practice. TI is not responsible or liable for any such statements.

Buyers and others who are developing systems that incorporate TI products (collectively, "Designers") understand and agree that Designers remain responsible for using their independent analysis, evaluation and judgment in designing their applications and that Designers have full and exclusive responsibility to assure the safety of Designers' applications and compliance of their applications (and of all TI products used in or for Designers' applications) with all applicable regulations, laws and other applicable requirements. Designer represents that, with respect to their applications, Designer has all the necessary expertise to create and implement safeguards that (1) anticipate dangerous consequences of failures, (2) monitor failures and their consequences, and (3) lessen the likelihood of failures that might cause harm and take appropriate actions. Designer agrees that prior to using or distributing any applications that include TI products, Designer will thoroughly test such applications and the functionality of such TI products as used in such applications.

TI's provision of technical, application or other design advice, quality characterization, reliability data or other services or information, including, but not limited to, reference designs and materials relating to evaluation modules, (collectively, "TI Resources") are intended to assist designers who are developing applications that incorporate TI products; by downloading, accessing or using TI Resources in any way, Designer (individually or, if Designer is acting on behalf of a company, Designer's company) agrees to use any particular TI Resource solely for this purpose and subject to the terms of this Notice.

TI's provision of TI Resources does not expand or otherwise alter TI's applicable published warranties or warranty disclaimers for TI products, and no additional obligations or liabilities arise from TI providing such TI Resources. TI reserves the right to make corrections, enhancements, improvements and other changes to its TI Resources. TI has not conducted any testing other than that specifically described in the published documentation for a particular TI Resource.

Designer is authorized to use, copy and modify any individual TI Resource only in connection with the development of applications that include the TI product(s) identified in such TI Resource. NO OTHER LICENSE, EXPRESS OR IMPLIED, BY ESTOPPEL OR OTHERWISE TO ANY OTHER TI INTELLECTUAL PROPERTY RIGHT, AND NO LICENSE TO ANY TECHNOLOGY OR INTELLECTUAL PROPERTY RIGHT OF TI OR ANY THIRD PARTY IS GRANTED HEREIN, including but not limited to any patent right, copyright, mask work right, or other intellectual property right relating to any combination, machine, or process in which TI products or services are used. Information regarding or referencing third-party products or services does not constitute a license to use such products or services, or a warranty or endorsement thereof. Use of TI Resources may require a license from a third party under the patents or other intellectual property of the third party, or a license from TI under the patents or other intellectual property of TI.

TI RESOURCES ARE PROVIDED "AS IS" AND WITH ALL FAULTS. TI DISCLAIMS ALL OTHER WARRANTIES OR REPRESENTATIONS, EXPRESS OR IMPLIED, REGARDING RESOURCES OR USE THEREOF, INCLUDING BUT NOT LIMITED TO ACCURACY OR COMPLETENESS, TITLE, ANY EPIDEMIC FAILURE WARRANTY AND ANY IMPLIED WARRANTIES OF MERCHANTABILITY, FITNESS FOR A PARTICULAR PURPOSE, AND NON-INFRINGEMENT OF ANY THIRD PARTY INTELLECTUAL PROPERTY RIGHTS. TI SHALL NOT BE LIABLE FOR AND SHALL NOT DEFEND OR INDEMNIFY DESIGNER AGAINST ANY CLAIM, INCLUDING BUT NOT LIMITED TO ANY INFRINGEMENT CLAIM THAT RELATES TO OR IS BASED ON ANY COMBINATION OF PRODUCTS EVEN IF DESCRIBED IN TI RESOURCES OR OTHERWISE. IN NO EVENT SHALL TI BE LIABLE FOR ANY ACTUAL, DIRECT, SPECIAL, COLLATERAL, INDIRECT, PUNITIVE, INCIDENTAL, CONSEQUENTIAL OR EXEMPLARY DAMAGES IN CONNECTION WITH OR ARISING OUT OF TI RESOURCES OR USE THEREOF, AND REGARDLESS OF WHETHER TI HAS BEEN ADVISED OF THE POSSIBILITY OF SUCH DAMAGES.

Unless TI has explicitly designated an individual product as meeting the requirements of a particular industry standard (e.g., ISO/TS 16949 and ISO 26262), TI is not responsible for any failure to meet such industry standard requirements.

Where TI specifically promotes products as facilitating functional safety or as compliant with industry functional safety standards, such products are intended to help enable customers to design and create their own applications that meet applicable functional safety standards and requirements. Using products in an application does not by itself establish any safety features in the application. Designers must ensure compliance with safety-related requirements and standards applicable to their applications. Designer may not use any TI products in life-critical medical equipment unless authorized officers of the parties have executed a special contract specifically governing such use. Life-critical medical equipment is medical equipment where failure of such equipment would cause serious bodily injury or death (e.g., life support, pacemakers, defibrillators, heart pumps, neurostimulators, and implantables). Such equipment includes, without limitation, all medical devices identified by the U.S. Food and Drug Administration as Class III devices and equivalent classifications outside the U.S.

TI may expressly designate certain products as completing a particular qualification (e.g., Q100, Military Grade, or Enhanced Product). Designers agree that it has the necessary expertise to select the product with the appropriate qualification designation for their applications and that proper product selection is at Designers' own risk. Designers are solely responsible for compliance with all legal and regulatory requirements in connection with such selection.

Designer will fully indemnify TI and its representatives against any damages, costs, losses, and/or liabilities arising out of Designer's non-compliance with the terms and provisions of this Notice.